

East Midlands Gateway Phase 2 (EMG2)

Document DCO 6.6A/MCO 6.6A (Part 3)

ENVIRONMENTAL STATEMENT

Technical Appendices

Appendix 6A

Transport Assessment

~~October 2025~~ April 2026

06

The East Midlands Gateway Phase 2
and Highway Order 202X and The East Midlands Gateway
Rail Freight and Highway (Amendment) Order 202X

[SEGRO.COM/SLPEMG2](https://www.segro.com/slpemg2)

SEGRO

**The East Midlands Gateway Phase 2 and
Highway Order 202X and The East Midlands
Gateway Rail Freight and Highway (Amendment)
Order 202X**

**APPENDIX 6.6A TRANSPORT ASSESSMENT
(PART 3)
(DOCUMENT DCO 6.6A/MCO 6.6A)**

<u>Version</u>	<u>Date</u>	<u>Status of Version</u>
<u>0</u>	<u>October 2025</u>	<u>Submission</u>
<u>1</u>	<u>April 2026</u>	<u>Deadline 1</u>

APPENDIX 23: A50 Junction 1 approved signalisation scheme

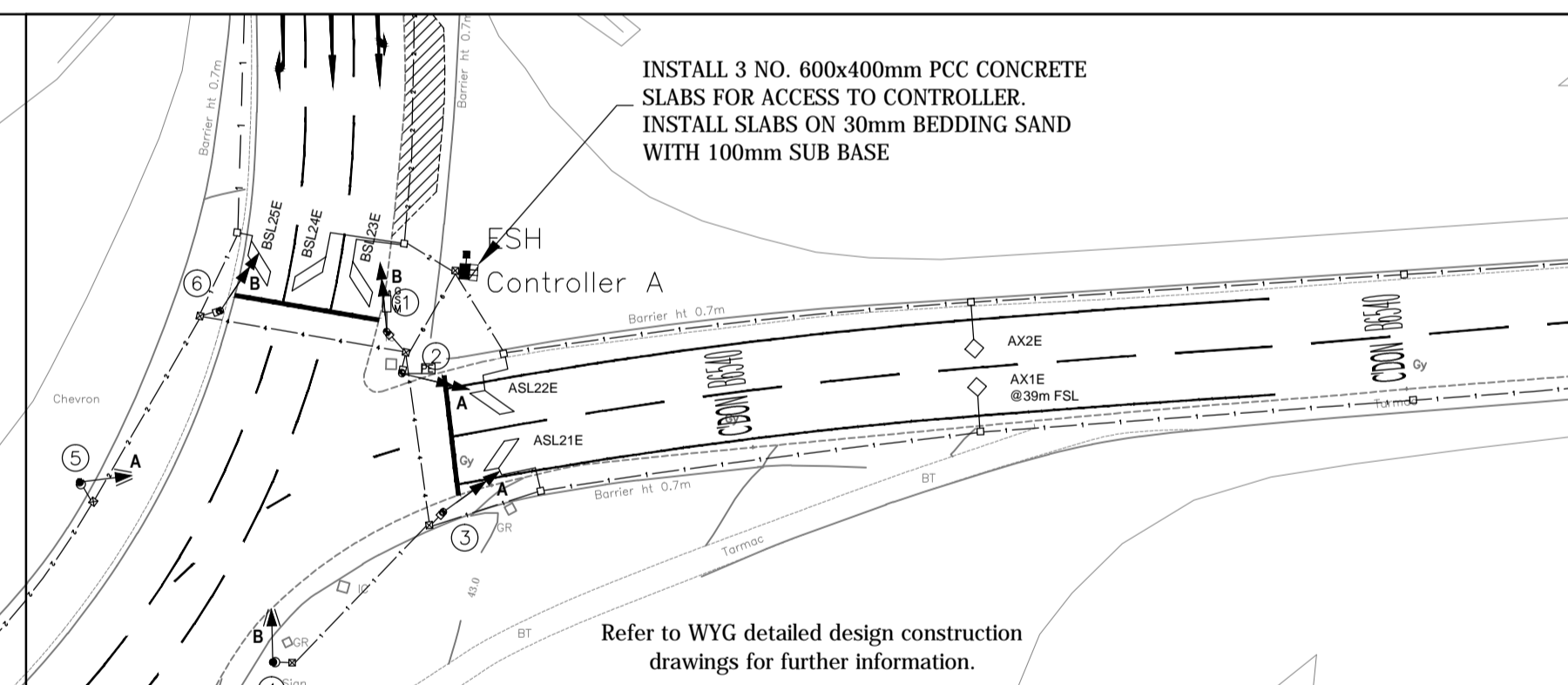
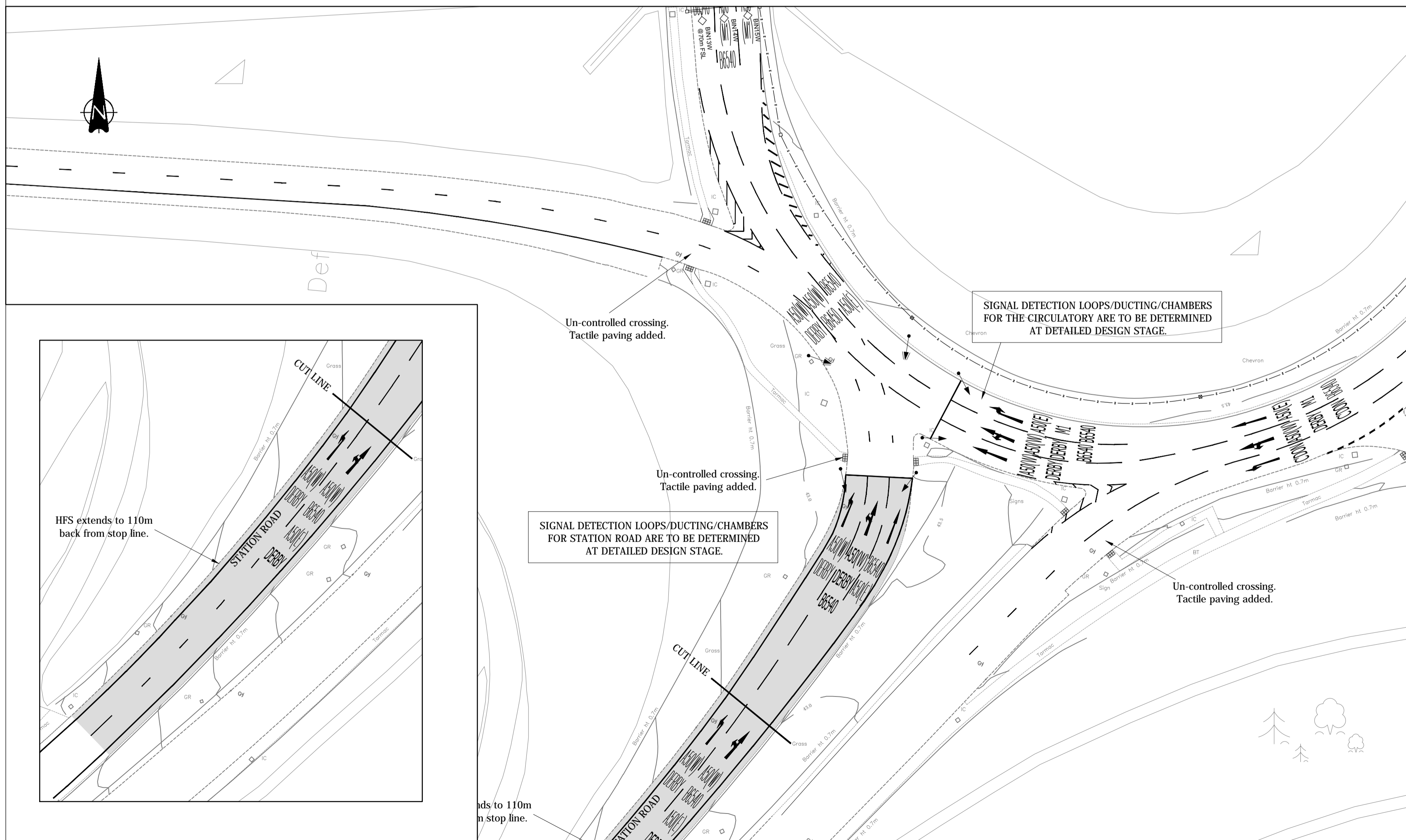
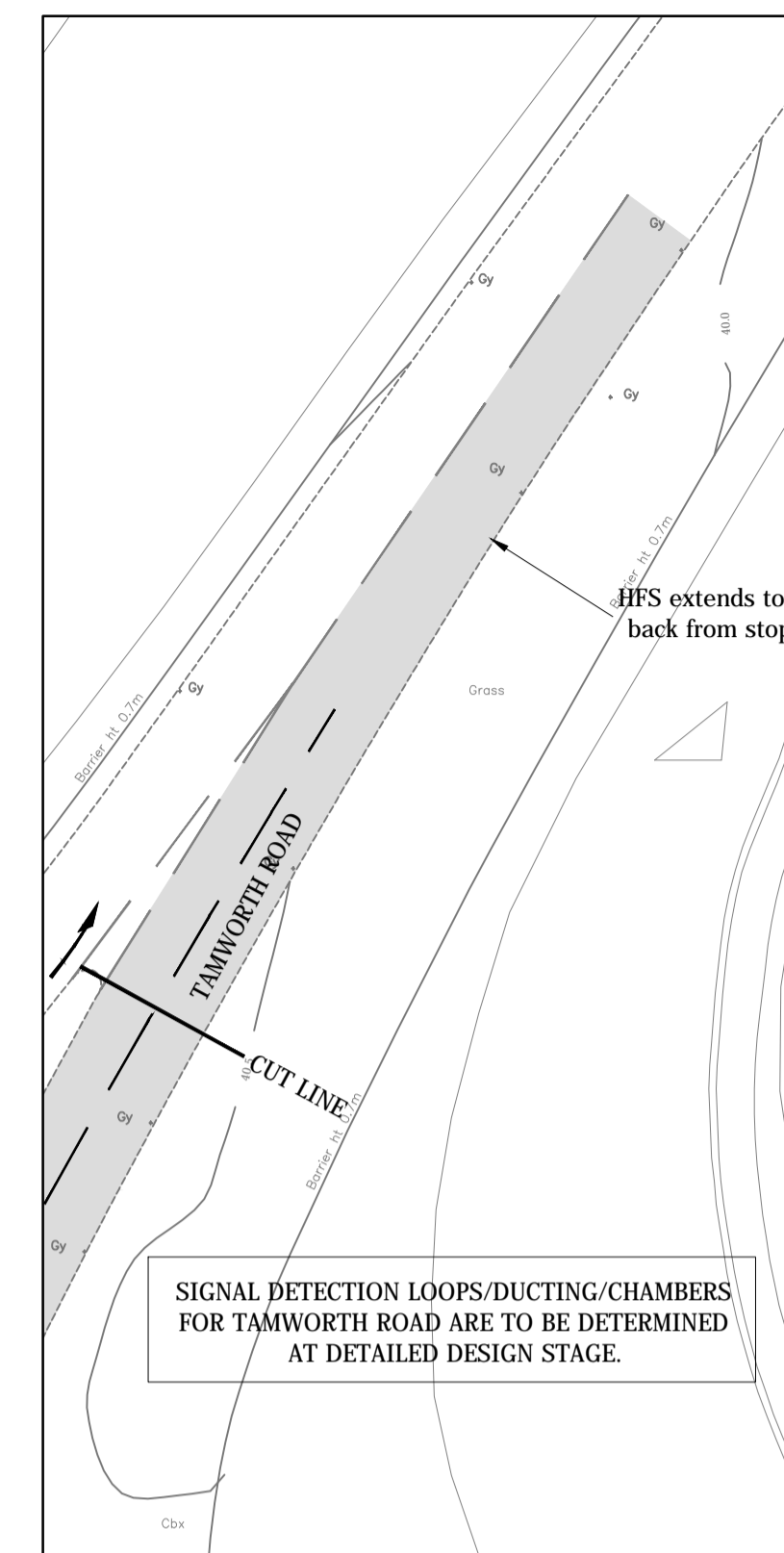
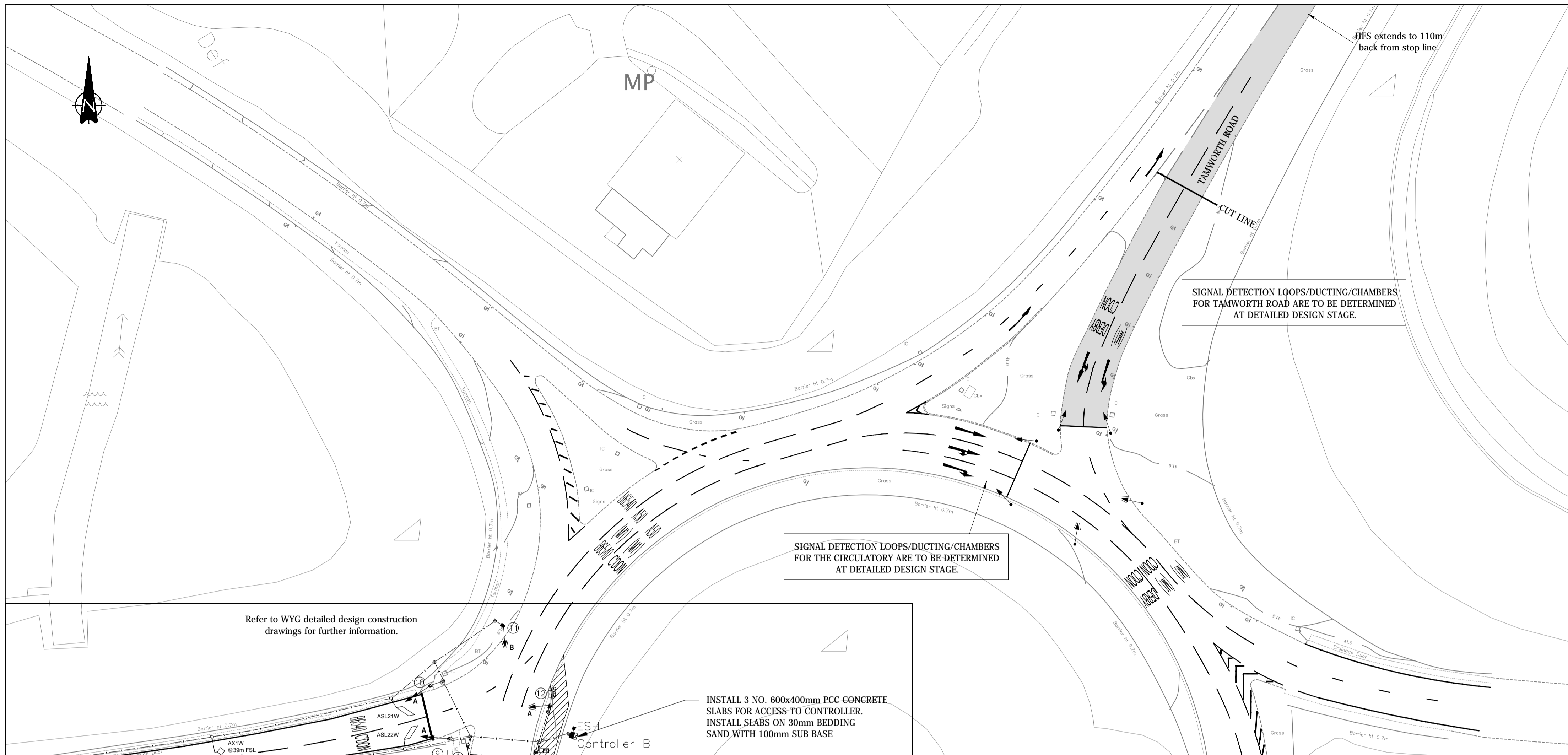

- Key:**
- OS Mapping
 - White Young Green Proposals
 - Waterman Boreham Proposals
 - Waterman Boreham proposed High Friction Surfacing

- Notes:**
- 1) All works shown BLACK on the drawing have been submitted to LA for technical approval by White Young Green. Refer to WYG detailed design drawing A060910-35-12/001 General Arrangement and related drawings for further information.
 - 2) All works shown RED on the drawing indicate Waterman Boreham proposals.
 - 3) As stated on the drawing all signal loops/ducting/chambers for Station Road/Tamworth Road and the circulatory carriageway will be determined and detailed design stage.

Rev	Date	Description	By
E	06.03.12	Amended in accordance with Highways Agency comments 23rd February 2012	HS
D	30.01.12	Amended following RSA 1/2.	CD
C	18:01:12	Amended following LCC comments dated 17.01.12.	CD
B	12:01:12	Amended following LCC comments.	CD
A	20:12:11	Amended to show proposals only.	CD

Amendments

Project **Park Lane, Castle Donington.**

Title **Proposed signalisation of Tamworth Road and Station Road approaches at the A50 Sawley Interchange.**

Client **Clowes Development Ltd and Miller Homes Ltd.**

2nd Floor South Central 11 Peter Street Manchester M2 5QR
 0161 839 8382 / 0161 839 8394
 enquiries@waterman-boreham.com www.waterman-boreham.com

Drawing Status

PRELIMINARY

Designed by	NJH	Checked by	NJH	Project No.	218012
Drawn by	CD	Date	15.11.11	Computer File No.	218012-0014
Scales @ A1	500	work to figured dimensions only			
Publisher	Zone	Category	Number	Revision	
WB	SA	95	014	E	

**APPENDIX 24: Walking, Cycling and Horse-Riding Assessment & Review - Review Report
(document reference EMG2-BWB-GEN-XX-RP-CH-0018_S4-P01)**

TRANSPORT AND INFRASTRUCTURE

SEGRO

East Midlands Gateway 2 (EMG2)

Walking, Cycling, Horse-riding

Assessment and Review (WCHAR)

Preliminary design stage – review report

DOCUMENT ISSUE RECORD

Document Number:	EMG2-BWB-GEN-XX-RP-CH-0018
BWB Reference:	220500

Revision	Date of Issue	Status	Author:	Checked:	Approved:
P01	20.06.2025	S4	<div style="background-color: black; width: 100px; height: 15px; margin-bottom: 5px;"></div> MEng (Hons) CEng MICE MCIHT	<div style="background-color: black; width: 100px; height: 15px; margin-bottom: 5px;"></div> <div style="background-color: black; width: 100px; height: 15px; margin-bottom: 5px;"></div> MICE	<div style="background-color: black; width: 50px; height: 15px; margin-bottom: 5px; display: inline-block;"></div> <div style="background-color: black; width: 50px; height: 15px; margin-bottom: 5px; display: inline-block;"></div> MEng (Hons) CEng MICE MCIHT

Notice

This document has been prepared for the sole use of the Client in accordance with the terms of the appointment under which it was produced. BWB Consulting Limited accepts no responsibility for any use of or reliance on the contents of this document by any third party. No part of this document shall be copied or reproduced in any form without the prior written permission of BWB.

CONTENTS

1.	INTRODUCTION.....	1
	Instruction	1
	Objectives	1
2.	BACKGROUND AND HIGHWAY TEAM DESCRIPTION.....	2
	Background.....	2
	Proposed highway scheme	2
	Review team	3
	Preceding assessment and review.....	3
	WCHAR study area.....	4
	Stakeholder engagement and site visits	4
3.	REVIEW OF WCHAR ASSESSMENT OPPORTUNITIES	5
4.	PRELIMINARY DESIGN STAGE REVIEW OPPORTUNITIES	8
5.	WALKING, CYCLING & HORSE RIDING REVIEW TEAM STATEMENT	10

1. INTRODUCTION

Instruction

- 1.1 BWB Consulting Ltd has been commissioned by Segro (the client) to undertake the highway design for the proposed East Midland Gateway 2 (EMG2) scheme.
- 1.2 The scheme is to provide primary access to the proposed EMG2 development and changes to the surrounding strategic and local road networks to serve and support the predicted increased traffic to the development.
- 1.3 A general site location plan is shown at **Figure 1** below.

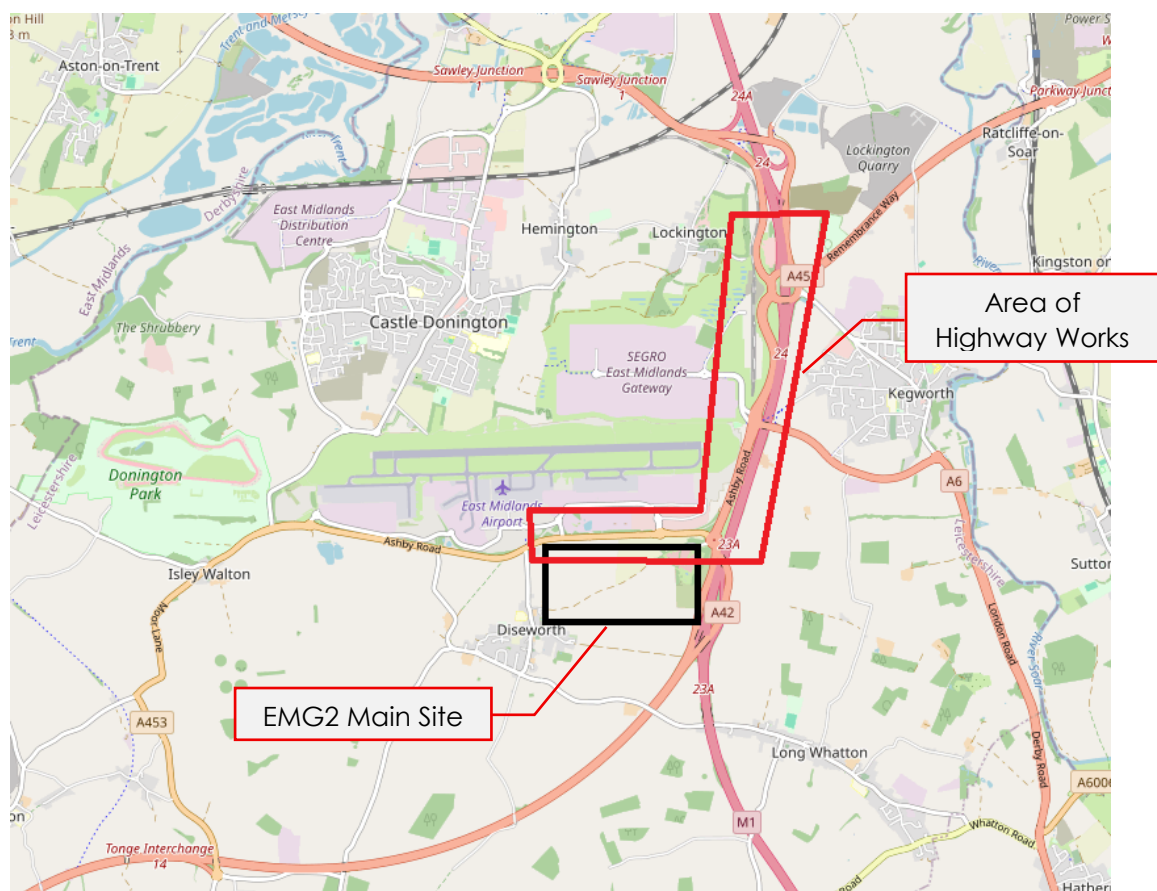

Figure 1: scheme location (Map data from OpenStreetMap : <https://www.openstreetmap.org/copyright>)

Objectives

- 1.4 This Report results from a Walking, Cycling & Horse-riding assessment and review (WCHAR) preliminary design stage Review undertaken for the Scheme and has been undertaken in accordance with DMRB GG 142 "Walking, Cycling & Horse-riding Assessment and Review".

2. BACKGROUND AND HIGHWAY TEAM DESCRIPTION

Background

- 2.1 At the Assessment stage the scheme was judged to be a **large highway scheme**. This is confirmed with reference to GG142 tables 2.2.1 and 2.2.1N and therefore reviews are to be undertaken at both preliminary and detail design stages.
- 2.2 This Review, at the preliminary design stage, has been undertaken concurrently with the preliminary design and has been carried out in accordance with GG 142 "Walking, Cycling & Horse-riding Assessment and Review".
- 2.3 The existing highway layout affected by the works comprise:
- M1 Junction 24 signalised roundabout which connects to the A453, M1 and local roads to Kegworth and Lockington;
 - M1 southbound/A50 eastbound link to junction 24;
 - A50 westbound exit from junction 24;
 - A453 / A6 / EMG1 signalised site access junction;
 - A453 corridor from the Finger Farm roundabout to the Hunter Road roundabout inclusive;
 - A453 East Midlands Airport (EMA) signalised access junction;
 - Hyam's Lane (unclassified dead-end country lane with gravel surface); and
 - Long Holden (unclassified dead-end country lane with gravel surface).

Proposed highway scheme

- 2.4 A package of highway works is proposed including: a new primary development access; substantial improvements around J24 of the M1; minor works on the local highways network; and pedestrian/cycle route enhancements.
- 2.5 A more detailed breakdown of these works is listed below and are shown diagrammatically on the components of the proposed development plan (Document DCO 2.7 & MCO 2.7):
- J24 Improvements comprising:
 - Works to the M1 northbound (DCO Works No. 8);
 - Construction of link road from the M1 northbound to the A50 westbound (DCO Works No. 9);
 - Works to the A50 westbound (DCO Works No. 10);
 - Works to the link road from the M1 southbound and A50 eastbound to M1 Junction 24 (DCO Works No. 11);
 - Works to the west side of the M1 Junction 24 roundabout and A453 northbound approach (DCO Works No. 12a); and
 - Works to the east side of the M1 Junction 24 roundabout and A453 southbound approach (DCO Works No. 12b).

- EMG1 Access Improvements comprising:
 - Signalised pedestrian crossing at the EMG1 exit road (MCO Works No. 8A); and
 - Capacity improvements (DCO Works No. 13).
- Finger Farm roundabout improvements (DCO Works No. 18)
- Active Travel works comprising:
 - Active Travel Link between EMG1 and EMA/EMG2 (DCO Works No. 14) ;
 - Hyam's Lane Works (DCO Works No. 7) ;
 - A453/East Midlands Airport (EMA) junction uncontrolled crossing (DCO Works No. 15);
 - Long Holden works (DCO Works No. 17); and
 - L57 footpath upgrade (DCO Works No. 19).

2.6 For the purposes of providing a comprehensive approach to walking, cycling and horse-riding assessment and review, the highway works are considered to include the main estate road and other publicly accessible infrastructure within both the existing EMG1 and the proposed EMG2 main site.

2.7 The preliminary design scheme drawings have been reviewed to:

- Ensure that previously identified opportunities at the assessment phase have been taken into account and implemented where achievable; and
- Identify opportunities for improvement for pedestrians, cyclists and equestrians as a result of the developing highway scheme design.

2.8 The following Scheme drawings have been reviewed:

Drawing	Title	Revision
EMG2-BWB-HGN-XX-DR-H-0101	EMG2 Highway Plan GA Sheet 1	P05
EMG2-BWB-HGN-XX-DR-H-0102	EMG2 Highway Plan GA Sheet 2	P05
EMG2-BWB-HGN-XX-DR-H-0103	EMG2 Highway Plan GA Sheet 3	P05

Review team

2.9 The Review team consists of:

Role	Organisation	Contact name	Email	Phone
Lead Assessor	BWB Consulting	[REDACTED]	[REDACTED]	0115 924 1100
Design Team Leader and Assessor	BWB Consulting	[REDACTED]	[REDACTED]	0115 924 1100

Preceding assessment and review

2.10 The WCHAR Assessment report was issued in March 2025 with minor updates in May 2025 in accordance with GG 142 "Walking, Cycling & Horse-riding Assessment and Review". The WCHAR Assessment is therefore up to date.

WCHAR study area

- 2.11 The study area is shown at **Figure 2** below and is considered to be correct for the scheme.

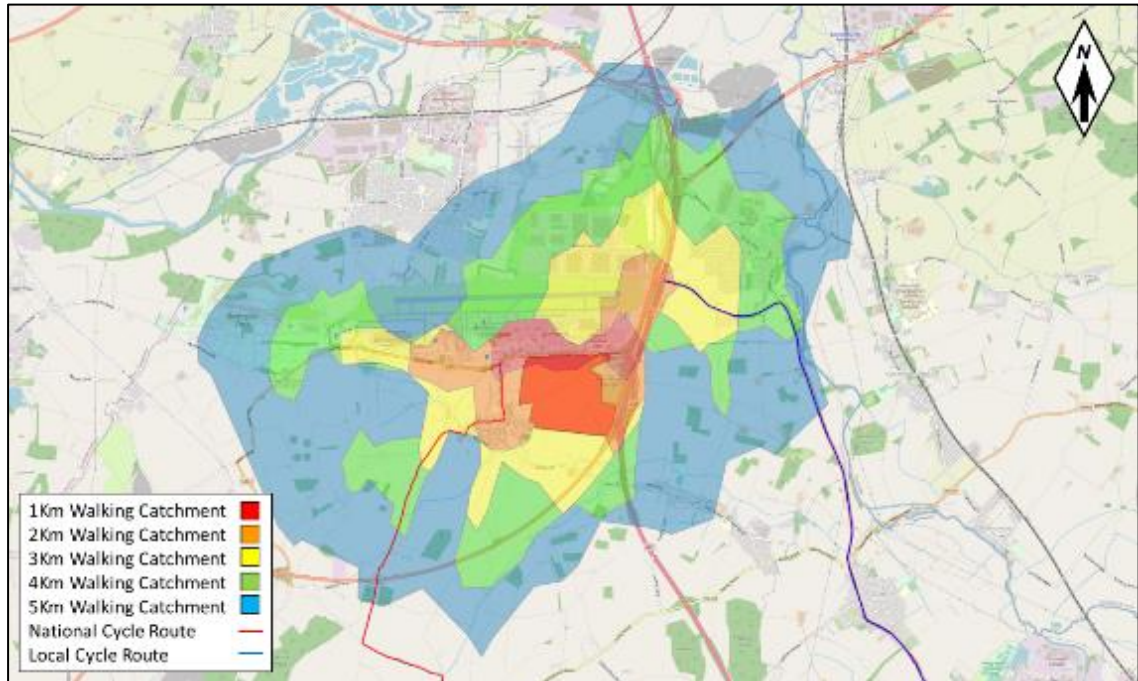

Figure 2 – WCHAR study area

Stakeholder engagement and site visits

- 2.12 The design proposals have been discussed with both National Highways (NH) and Leicestershire County Council (LCC) as local highway authority. Both authorities will be further consulted with throughout the preliminary and detailed design stages.
- 2.13 As discussed in the WCHAR Assessment public consultation was undertaken during February and March 2025 which has helped inform the opportunities. Further consultation is to take place during June and July 2025.
- 2.14 Site visits have been undertaken as set out in the WCHAR Assessment.

3. REVIEW OF WCHAR ASSESSMENT OPPORTUNITIES

- 3.1 This section provides a summary of the opportunities identified as part of the Assessment report together with the actions taken and outcomes. They are provided verbatim from the assessment report. Note that the opportunity references are amended to enable additional opportunities to be added during the review stages, the original references in the Assessment report are shown in brackets.
- 3.2 To assist the key stakeholders in reviewing this document the location of the opportunity and which highway authority(ies) it affects has been included.

Opportunity		Location / Highway authority	Actions taken / outcomes
	General opportunities		
G1 (1)	Consider the provision of a shared footway /cycleway within the [EMG2 Main] site.	EMG2 main site: private	Outcome: the scheme provides a shared use footway/cycleway along the spine road of the EMG2 main site and this connects into the proposals for Hyam's Lane (opportunity S1).
G2 (2)	Consider providing a footway/cycleway along the western side of the A453 to provide a connection between EMG2 and EMG1 which would provide wider connectivity between the surrounding areas such as EMA and Kegworth	A453 corridor: NH (part) & LCC (part)	Outcome: the scheme will provide a new cycle track on the western side of the A453 from the EMG1 access junction, south to the A453 Finger Farm roundabout and then to the A453 Hunter Road roundabout. It will utilise former A453 road alignments where available but will need to go into land outside of the current or former road alignments in the vicinity of the northbound lay-by.
G3 (3)	Consider providing appropriate pedestrian and cyclist crossing facilities along the access roads within [the] EMG2 [Main site] to provide safe crossing opportunities	EMG2 main site: private infrastructure	Future Action: as the EMG2 main site road layout is illustrative at this stage this is to be further reviewed at the detailed design stage. However, we see no reason as to why this objective cannot be achieved.
G4 (4)	Consider providing appropriate pedestrian and cyclist crossing points on the A453 at the EMA junction and to east of the proposed site access, to enhance connectivity to EMG1 and EMA to provide a safe crossing facility for pedestrians and cyclists	A453 corridor: LCC	Outcome: the scheme provides an uncontrolled crossing at the EMA signalised junction which is to connect the new leisure route within EMG2. Outcome: the scheme provides a controlled (toucan) crossing between the A453 Hunter Road roundabout and the Finger farm roundabout, which connects to the route to EMG1 (opportunity G2)
G5 (5)	Consider upgrading Footpath Link 57 to connect Castle Donington to EMG1 and then onto EMG2 via EMG1 and the new A453 link	L57 footpath: LCC	Outcome: an upgrade of this footpath to a cycle track (for use by pedestrians and cyclists) is included in the scheme

Opportunity		Location / Highway authority	Actions taken / outcomes
	Strategic opportunities		
S1 (6)	Consideration should be given to ensuring that the proposals take into consideration the existing PROWs including Hyam's Lane and National and local cycle links and how the development proposals can tie into them to enhance connectivity to Long Holden	Various local roads and PROW: LCC	<p>Outcome: the scheme retains Hyam's Lane which will be upgraded to become a cycle corridor connecting Diseworth to the A453 at the Hunter Road roundabout (and then to Kegworth via the new infrastructure identified at opportunity G2)</p> <p>Outcome: the scheme will enhance the PROW network around the EMG2 main site by (a) providing a new PROW between the A453 EMA access junction, Hyam's Lane and Long Holden along the western boundary of the EMG2 main site; and (b) a new PROW along the eastern boundary of the EMG2 main site between Hyam's Lane and Long Holden</p>
S2 (7)	Consideration should be given to making Hyam's Lane part of NCN15 and then extending the link through the site, up the A453 to EMG1 and to Kegworth (see opportunity 2)	Hyam's Lane: LCC A453 corridor: NH (part) & LCC (part)	Future Action: this is agreed in principle but signage is a detailed design matter so this will be reviewed further at the detailed design stage.
S3 (8)	Consideration should be given to whether any improvements could be made to the pedestrian / cycle routes south from Diseworth that would provide a shorter connection to Loughborough for employees (as well as benefits for residents).	Various local roads: LCC	Outcome: this has been reviewed as part of the overall sustainable transport assessment for the EMG2 scheme which concluded that there is no justification for this to form part of the EMG2 scheme
	Pedestrian specific opportunities		
P1 (9)	<p>Consider how wider connectivity of Hyam's Lane (which is being retained within the site) can be enhanced, this could include:</p> <ul style="list-style-type: none"> - Additional south-easterly connection from Hyam's Lane to the Country Park (adjacent to the Moto Donington Services). - an additional northerly connection from Hyam's Lane to the proposed EMG2 Bus Interchange. - an additional southerly connection from Hyam's Lane to Long Holden, this connection provides access directly into the EMG2 estate 	Various local roads and PROW: LCC	<p>Outcome: following consultation with Moto, a connection into the rear of their site is not possible due to security requirements for motorway service areas</p> <p>Outcome: Hyam's Lane is to be connected by a new shared use footway/cycleway to the A453 Hunter Road roundabout via the bus interchange</p> <p>Outcome: new PROW between Hyam's Lane and Long Holden are to be provided east and west of the EMG2 main site</p>

Opportunity		Location / Highway authority	Actions taken / outcomes
	Cyclist specific opportunities		
C1 (10)	Consider whether existing footways in the vicinity of the [EMG2 main] site can be upgraded to shared cycleway / footways to enhance connectivity.	Various local roads: LCC	Outcome: Hyam's Lane is to be upgraded to a cycle track for pedestrians and cyclists, extended to the A453 Hunter Road roundabout and north of there a new cycle track provided to the EMG1 junction alongside the A453. Elsewhere there are no other identified footways within the vicinity of the EMG2 main site that would merit upgrading for use by cyclists.
	Equestrian specific opportunities		
	None identified		

4. PRELIMINARY DESIGN STAGE REVIEW OPPORTUNITIES

4.1 This section documents any user related opportunities identified during the preliminary design phase. They have been developed through discussions between the Lead Assessor and the wider design team and recorded here along with actions taken / outcomes. The numbering is a continuation of the numbers used at the assessment stage.

Opportunity		Location / Highway authority	Actions taken / outcomes
General opportunities			
G6	Improve the environment of Long Holden and reduce the risk of anti-social behaviour and parking	Long Holden and PROW: LCC	Action taken: all-purpose road status is proposed to be removed and it is proposed to be designated as a public bridleway. Gated access is proposed for walkers, cyclists and horse-riders for public use along with private use for access to adjoining land.
Strategic opportunities			
No further opportunities identified			
Pedestrian specific opportunities			
P2	As part of the EMG1 Works provide an opportunity for pedestrians to be safely dropped of at the EMG1 exit to then access the bus interchange	EMG1 estate roads: Private A453: NH	Outcome: this is included in the scheme design
Cyclist specific opportunities			
No further opportunities identified			
Equestrian specific opportunities			
E1	There is an opportunity to provide a loop for equestrians on the eastern side of Diseworth using Long Holden, Hyam's Lane and the new PROW connecting the two. (This directly addresses public feedback received during the consultation).	Various local roads and PROW: LCC	Action taken: a bridleway connection is proposed on the western side of the EMG main site between Long Holden and Hyam's Lane.

General Opportunity G6 (image courtesy of Google)



Pedestrian Opportunity P2

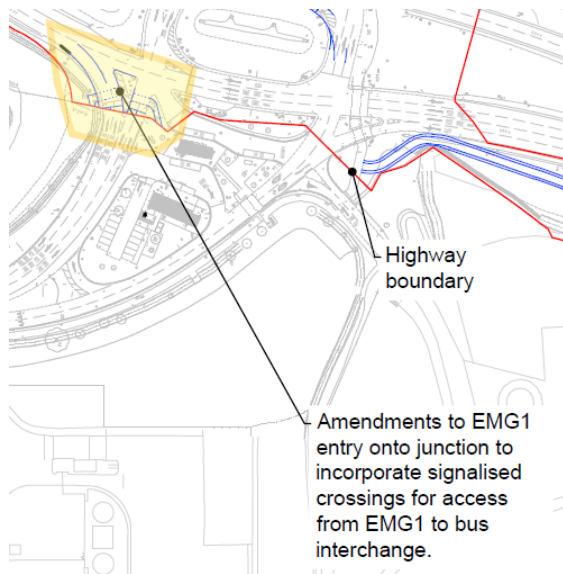

Equestrian Opportunity E1

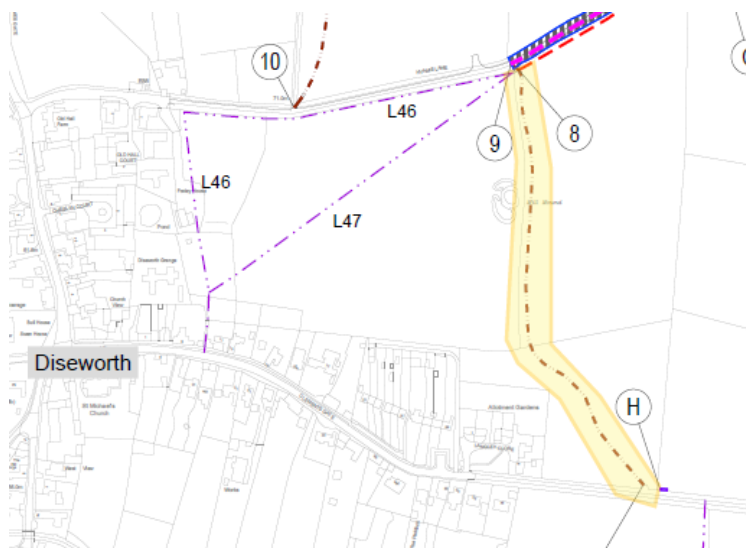

5. WALKING, CYCLING & HORSE RIDING REVIEW TEAM STATEMENT

5.1 As Lead Assessor, I confirm that this walking, cycling and horse-riding review report has been compiled in accordance with DMRB GG 142 and thus records all design team deliberations and decisions relating to walking, cycling and horse-riding issues and opportunities. The walking, cycling and horse-riding review was undertaken by the following team:

Name:	██████████
Position:	Lead Assessor
Organisation:	BWB Consulting Ltd
Signed & Dated:	

Name:	███████
Position:	Design team leader and Assessor
Organisation:	BWB Consulting Ltd

5.2 As design team leader, I confirm that the assessment has been undertaken at the appropriate stage of the highway scheme development. I confirm that in my professional opinion the appointed Lead Assessor has the appropriate experience for the role making reference to the expected competencies contained in DMRB GG 142.

Name:	███████
Position:	Design Team Leader
Organisation:	BWB Consulting Ltd
Signed & Dated:	



APPENDIX 25: BREAAAM Accessibility Index Calculator (existing site)

BREEAM 2018 Tra01/02 Accessibility Index calculator

Using the drop down boxes make the relevant selections and press the 'Select' button

Building type

No. nodes required

Select

NODE 1

Public transport type	Bus									
Distance to node (m)	500									
Average frequency per hour	Service 1	Service 2	Service 3	Service 4	Service 5	Service 6	Service 7	Service 8	Service 9	Service 10
	4	2	3	1	2					

NODE 2

Public transport type	Bus									
Distance to node (m)										
Average frequency per hour	Service 1	Service 2	Service 3	Service 4	Service 5	Service 6	Service 7	Service 8	Service 9	Service 10

Accessibility Index	4.41
---------------------	------

**APPENDIX 26: Geometric Design Strategy Record for the local highway network
(document reference EMG2-BWB-GEN-XX-RP-CH-0017_S3-P02)**

INFRASTRUCTURE

SEGRO
East Midlands Gateway 2
Leicestershire
Geometric Design Strategy Record
(Local Highways Network)

INFRASTRUCTURE

SEGRO
East Midlands Gateway 2
Leicestershire
Geometric Design Strategy Record
(Local Highways Network)

Nottingham
5th Floor, Waterfront House, Station Street
Nottingham, NG2 3DQ
T: 0115 924 1100

~~August 2025~~

DOCUMENT ISSUE RECORD

Document Number:	EMG2-BWB-GEN-XX-RP-CH-0017
BWB Reference:	220500

Revision	Date of Issue	Status	Author:	Checked:	Approved:
1	13.06.2025	For comment			
2	22.08.2025	For DCO submission			
<u>3</u>	<u>10.02.2026</u>	<u>For DCO submission</u>			
<u>4</u>	<u>05.03.2026</u>	<u>For DCO submission</u>			
<u>5</u>	<u>31.03.2026</u>	<u>For DCO submission</u>			

Notice

This document has been prepared for the sole use of the Client in accordance with the terms of the appointment under which it was produced. BWB Consulting Limited accepts no responsibility for any use of or reliance on the contents of this document by any third party. No part of this document shall be copied or reproduced in any form without the prior written permission of BWB.

CONTENTS

1. INTRODUCTION.....	1
Instruction	1
Acronyms and Abbreviations	2
Objectives	2
List of Drawings.....	2
2. SCHEME OVERVIEW AND DESIGN STANDARDS	4
Scheme overview.....	4
Overview of Standards	4
Highway Authority, Road Class, Design Speed and Speed Limit	5
3. A453 FINGER FARM ROUNDABOUT	6
Layout	6
Design Speed and Geometry	6
Visibility.....	6
4. A453 HUNTER ROAD / EMG2 PRIMARY ROUNDABOUT ACCESS JUNCTION	7
Layout	7
Traffic Flows	7
Design Speed and Geometry	8
Visibility	9
Departures From Standard	9
5. A453 SHARED USE CYCLEWAY/FOOTWAY	10
Layout	10
Traffic Flows	10
Design Speed and Geometry	10
Visibility	11
Departures From Standard	11
6. HYAM'S LANE CYCLE TRACK	12
Layout	12
Design Speed and Geometry	12
7. L57 FOOTPATH UPGRADE TO CYCLE TRACK	13
Layout	13
Design Speed and Geometry	13
1. INTRODUCTION.....	1
Instruction	1
Acronyms and Abbreviations	2
Objectives	2

List of Drawings.....	2
2. SCHEME OVERVIEW AND DESIGN STANDARDS	4
Scheme overview.....	4
Overview of Standards	4
Highway Authority, Road Class, Design Speed and Speed Limit	5
3. A453 FINGER FARM ROUNDABOUT	6
Layout	6
Design Speed and Geometry	6
Visibility	6
4. A453 HUNTER ROAD / EMG2 PRIMARY ROUNDABOUT ACCESS JUNCTION	7
Layout	7
Traffic Flows	7
Design Speed and Geometry	8
Visibility	9
5. A453 SHARED USE CYCLEWAY/FOOTWAY	10
Layout	10
Traffic Flows	10
Design Speed and Geometry	10
Visibility	11
6. HYAM'S LANE CYCLE TRACK	13
Layout	13
Design Speed and Geometry	13
7. L57 FOOTPATH UPGRADE TO CYCLE TRACK	15
Layout	15
Design Speed and Geometry	15

1. INTRODUCTION

Instruction

- 1.1 The EMG2 development is located south of East Midlands Airport (EMA) and proposes substantial improvements to the strategic road network (SRN) at M1 junction 24 along with works to the A453 south of J24 on the Local road network (LRN).
- 1.2 BWB Consulting (BWB) has been instructed by SEGRO (the Client) to develop the highway design for the works on both the SRN and LRN. This report provides a Design Strategy Record (DSR) for the LRN.
- 1.3 **Figure 1.1** below shows the overall location of the works on the LRN in the context of EMG2.

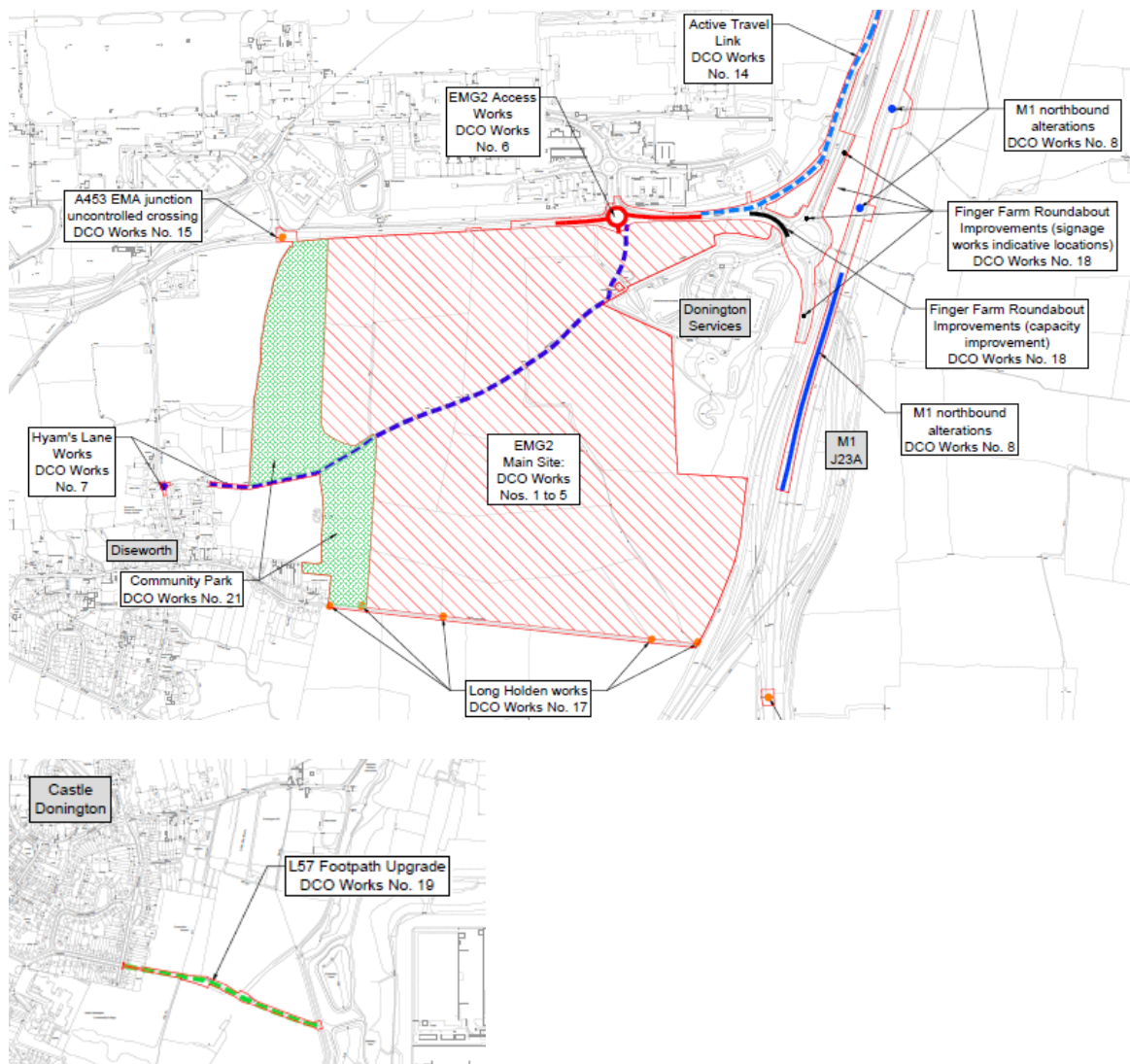

Figure 1.1 Location plan and LRN works

Acronyms and Abbreviations

DfT	Department for Transport
DMRB	Design Manual for Roads and Bridges
DSR	Design Strategy Record
EMA	East Midlands Airport
EMG1	East Midland Gateway 1
EMG2	East Midland Gateway 2
ICD	Inscribed Circle Diameter
LCC	Leicestershire County Council
LRN	Local Road Network
LTN	Local Transport Note
NH	National Highways
SRN	Strategic Road Network
SSD	Stopping Sight Distance

Objectives

- 1.4 The objective of this DSR is to record the key decisions made during the layout design. This DSR does not include the upgrading of footpath L57 to a cycle track (DCO Works No. 19) as the design of that has already been reviewed by LCC.
- 1.5 The report will record the relaxations and departures from standards contained within the highway design.
- 1.6 The following reports and documents are to be provided separately to this DSR:
 - Transport assessment and modelling;
 - Directional signage strategy;
 - Lighting strategy;
 - Maintenance and repair statement to GD 304;
 - WCHAR assessment and review to GG 142; and
 - Stage 1 road safety audit to GG 119.

List of Drawings

- 1.7 The table below sets out the scheme design and option drawings that are to be read in conjunction with this report. Where a drawing is a formal plan used for the DCO then the document number is given. Formal DCO plans are provided separately and are not appended to this report.

Drawing no.	Title	DCO doc no.
EMG2-BWB-HGN-XX-DR-H-0101	Highway Plans GA Sheet 1 of 4	DCO 2.8A
EMG2-BWB-HGN-XX-DR-H-0102	Highway Plans GA Sheet 2 of 4	DCO 2.8B
EMG2-BWB-HGN-A453-DR-H-0101	A453 Geometry Plans Sheet 1 of 4	n/a
EMG2-BWB-HGN-A453-DR-H-0102	A453 Geometry Plans Sheet 2 of 4	n/a
EMG2-BWB-HGN-A453-DR-H-0103	A453 Geometry Plans Sheet 3 of 4	n/a

Drawing no.	Title	DCO doc no.
EMG2-BWB-HGN-A453-DR-H-0110	A453 Vehicle Swept Paths & Visibility Sheet 1 of 4	n/a
EMG2-BWB-HGN-A453-DR-H-0110a	A453 Vehicle Swept Paths & Visibility Sheet 1a of 4	n/a
EMG2-BWB-HGN-A453-DR-H-0111	A453 Vehicle Swept Paths & Visibility Sheet 2 of 4	n/a
EMG2-BWB-HGN-A453-DR-H-0112	A453 Vehicle Swept Paths & Visibility Sheet 3 of 4	n/a
EMG2-BWB-HGN-HYAM-DR-H-0101	Hyam's Hyams Geometry Plans Sheet 1 of 2	n/a
EMG2-BWB-HGN-HYAM-DR-H-0102	Hyam's Hyams Geometry Plans Sheet 2 of 2	n/a
EMG2-BWB-HGN-HYAM-DR-H-0110	Hyam's Hyams Vehicle Swept Paths & Visibility Sheet 1 of 2	n/a
EMG2-BWB-HGN-HYAM-DR-H-0111	Hyam's Hyams Vehicle Swept Paths & Visibility Sheet 2 of 2	n/a
EMG2-BWB-HGN-04-DR-H-0100	L57 Footpath General Arrangement Layout	n/a
EMG2-BWB-HGT-A453-DR-H-0651	Highway Plans Long Sections Sheet 3 (A453 & L57)	DCO 2.10C
EMG2-BWB-HGT-HYAM-DR-H-0651	Highway Plans Long Sections Sheet 4 (Hyam's Hyams)	DCO 2.10D
EMG2-BWB-HGN-XX-DR-H-0131	Highway Plans Cross Sections Sheet 1 of 3	DCO 2.9A
EMG2-BWB-HGN-XX-DR-H-0132	Highway Plans Cross Sections Sheet 2 of 3	DCO 2.9B

2. SCHEME OVERVIEW AND DESIGN STANDARDS

Scheme overview

2.1 The proposed works on the LRN are listed below, collectively referred to within this report as the LRN works.

- New arm (to serve the EMG2 Main Site) and improvements to the A453 Hunter Road roundabout (DCO Works No. 6) comprising:
 - New southern arm to the roundabout to serve as primary access to the EMG2 development;
 - Carriageway widening to lengthen the existing 2 lane approach and exits on both A453 arms;
 - Provision of new Toucan signalised crossing of A453 between Finger Farm and Hunter Road roundabouts. Includes a new length of shared cycle/footway to the south from the crossing to Hunter Road roundabout and into the EMG2 development;
- Improvement to Finger Farm roundabout A453 westbound exit (DCO Works No. 18):
 - Carriageway widening to lengthen the existing 2 lane exit to increase capacity reducing the risk of merging traffic queuing back towards the roundabout;
- Provision of new and improvements to the existing shared unsegregated cycle/footway adjacent to the A453 between EMG1 and the EMG2 (up to the boundary with the SRN, north of this point this becomes part of the works on the SRN) (DCO Works No. 14);
- Conversion of [Hyam's Hyams](#) lane into a shared use cycle track (DCO Works No. 7); and
- Upgrade of public footpath L57 (connecting Castle Donington to EMG1 and thence onto EMG2) to a shared use cycle track (DCO Works No. 19).

2.2 The works to the EMA junction (DCO Works No. 15) and Long Holden (DCO Works No. 17) are minor and are therefore not covered by this report.

Overview of Standards

2.3 The scheme spans across two highway authority boundaries, NH and LCC. This report provides design commentary on the LCC's LRN works. The NH design commentary is covered by a separate report.

2.4 The LRN works will be designed in accordance with the following DMRB standards and DfT guidance:

Doc. Ref.	Document Title	Version / Revision
CD 109	Highway link design	Revision 1
CD 116	Geometric design of roundabouts	Version 2.1.0
CD 127	Cross-sections and headrooms	Version 1.0.1

Doc. Ref.	Document Title	Version / Revision
CD 143	Designing for walking, cycling and horse-riding	Version 2.0.1
LTN1/20	Cycle Infrastructure Design	July 2020

Highway Authority, Road Class, Design Speed and Speed Limit

2.5 The road class for the A453 west/east section between Finger Farm roundabout and the signalised junction access to the airport has been categorised as an urban all-purpose road following the proposed developed. This is due to the road having development both sides and a cross section with carriageway, footways and road lighting in line with the typical sections for urban single carriageway shown in CD 127 'Cross-sections and headrooms',

Section of scheme	Road class	Design speed	Existing or proposed signed speed limit (mph)
A453 between Finger Farm roundabout and the signalised junction access to EMA.	All-purpose	85kph	Existing 50mph signed speed limit to be retained.
Shared use cycle/footway or cycle track	N/A	30/40mph	Assessed based on longitudinal gradient in accordance with LTN1/20

3. A453 FINGER FARM ROUNDABOUT

Layout

- 3.1 The proposed works to the existing A453 Finger Farm roundabout is to extend the length of two-lane merge on the A453 westbound exit. The extension is to reduce the risk of merging traffic queuing back onto the roundabout.

Design Speed and Geometry

- 3.2 The proposed geometric changes to the roundabout are not influenced by design speed except for forward visibility exiting the roundabout. CD 116, para. 3.56 states that exit visibility from the ICD shall be in accordance with CD 109.
- 3.3 As detailed above, the A453 has been categorised as an urban all-purpose road and therefore the design speed based on the existing 50mph signed speed limit at 85kph (CD 109, para. 2.5 and Table 2.5).
- 3.4 The extension maintains the compliant horizontal and vertical geometry of the existing exit and provides minimum lane widths of 3.0m and a merge taper greater than 1 in 15 (CD 116, para. 3.28.3).

Visibility

- 3.5 The existing forward visibility (SSD) from the exit of the roundabout onto the A453 eastbound is currently sub-standard and constitutes a departure from standard. Drawing EMG2-BWB-HGN-A453-DR-H-0102 shows the achieved SSD of the proposals with minimal vegetation clearance which will remain an **existing departure from standard**. The drawing also shows the point at which desirable minimum SSD is achieved.

4. A453 HUNTER ROAD / EMG2 PRIMARY ROUNDABOUT ACCESS JUNCTION

Layout

- 4.1 The works to the existing A453 Hunter Road roundabout proposes a new arm off the south of the roundabout to serve the development.
- 4.2 Additionally, the works include widening of the approach and exits to both A453 arms of the roundabout to increase capacity and road safety.

Traffic Flows

- 4.3 **Figure 4.1 and 4.2** below set out the peak hour future assessment year traffic data for the development through the roundabout. Note the figures are orientated north.

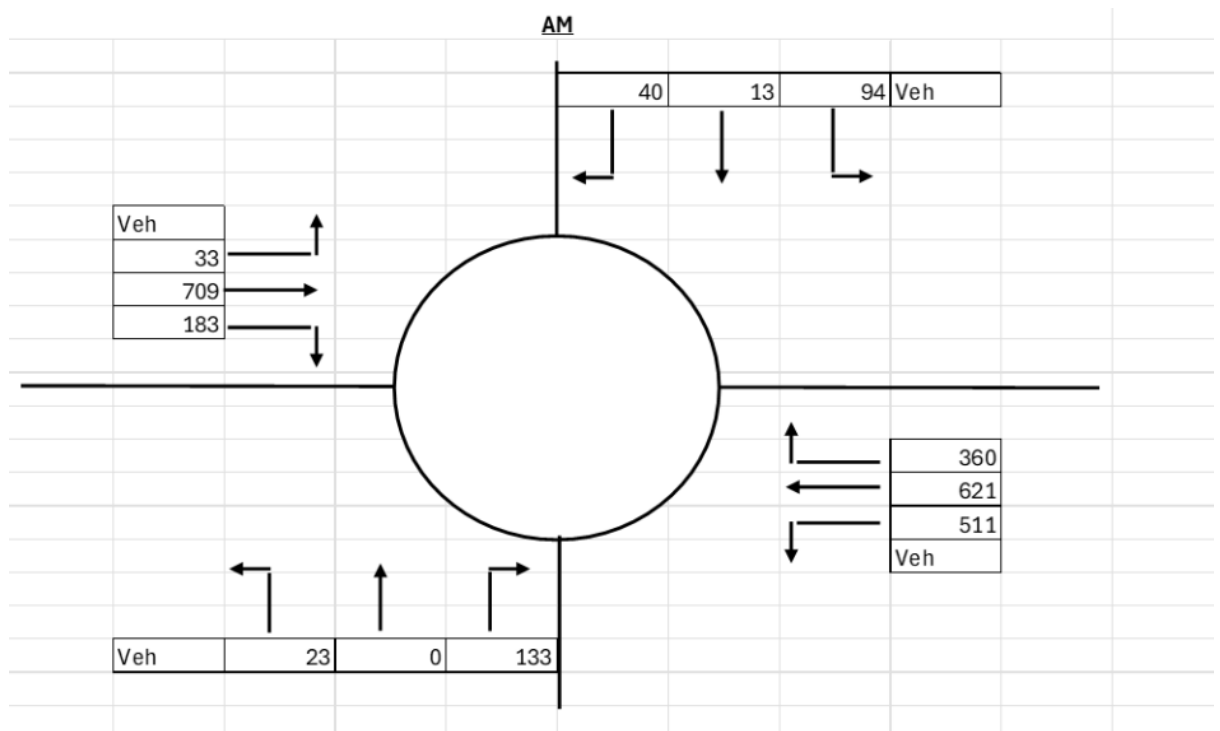

Figure 4.1 A453 Hunter Road roundabout forecast traffic flows AM peak hour

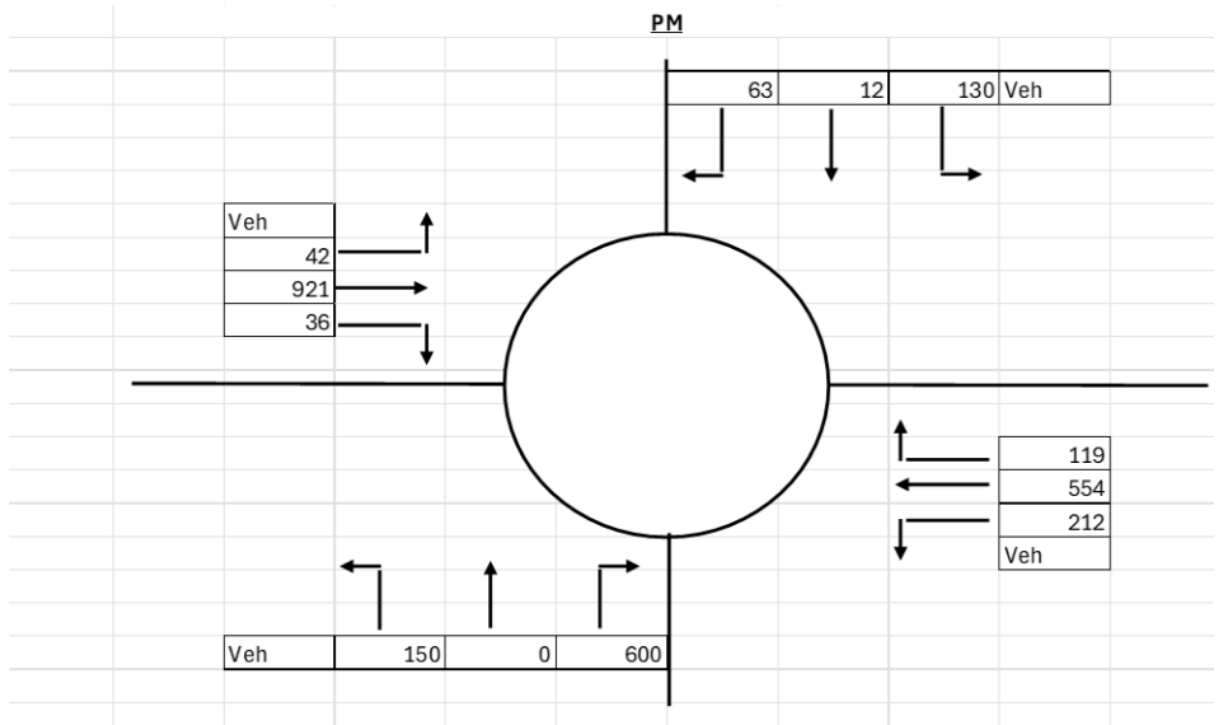

Figure 4.2 A453 Hunter Road roundabout forecast traffic flows PM peak hour

Design Speed and Geometry

- 4.4 The proposed works for the widening and increased length of the 2-lane approach and exits of the A453 arms, have been assessed in accordance with CD 116. Design speed does not influence the geometric design criteria for the proposals except for forward visibility. CD 116, para. 3.56 states that exit visibility from the ICD shall be in accordance with CD 109.
- 4.5 As detailed within paragraph 2.5 of this report, The A453 in this location has been categorised as an urban all-purpose road and therefore the design speed based on the existing 50mph signed speed limit at 85kph (CD 109, para. 2.5 and Table 2.5).
- 4.6 Drawing EMG2-BWB-HGN-A453-DR-H-0101 shows the detailed geometry proposals and assesses compliance with DMRB, notably CD 116 for the roundabout.
- 4.7 The proposed horizontal and vertical geometry changes to the A453 and proposed development arms have been designed to accommodate the swept path requirements for an HGV in the nearside lane and large car in the outside lane, and in accordance with the geometric requirements of CD 116. A check using the longer 18.5m articulated vehicle, introduced in 2023, has also been carried out. To achieve this the lane widths on the multi-lane entries are 4.5m which complies with the mandatory requirement of CD 116 para 3.14 but does not comply with para 3.14.2 and therefore the use of 4.5m lanes at the entries is a relaxation.

~~4.8 On the EMG2 exit the width of lane 1 at the exit is widened to allow for the swept path manoeuvres of the design vehicle. However, as the lane width exceeds 4.5m, this is a **departure from standard.**~~

Visibility

~~4.9.4.8~~ Visibility on the approach, circulatory and exit of the roundabout arms comply with the requirements of CD 116, para. 3.42 to 3.56.

Departures From Standard

~~4.10 There is one **departure from standard** for the proposed changes to Hunter Road roundabout. The nearside approach lane width on the new southern arm is 4.99m to accommodate the design vehicle swept path. CD 116, para 3.14 states the maximum lane width shall be no greater than 4.5m.~~

5. A453 SHARED USE CYCLEWAY/FOOTWAY

Layout

- 5.1 The works propose a new shared use unsegregated cycle/footway (shared facility) along the A453 between the existing A453 / A6 Kegworth Bypass / EMG1 (Wilders Way) access junction and the A453 Hunter Road / EMG2 access roundabout. The route is unlit except for where it runs adjacent to existing lit roads.
- 5.2 The shared use facility will connect to the existing shared unsegregated cycle/footway facility to the north for EMG1, Kegworth village and A6 Kegworth Bypass. To the south, connect into the existing shared facility along the A453 to the existing Beverley Road roundabout and will connect into the new facility that is proposed to run along [Hyam's Hyams Lane](#) to Diseworth.
- 5.3 This report provides design information for the section of shared facility from the National highways boundary adjacent to the airport (approximately 500m north of the existing Finger Farm roundabout) to the A453 Hunter Road / EMG2 access roundabout.
- 5.4 Consideration has been given to maintaining the existing access to the pumping station off A453 between Hunter Road and Finger Farm roundabouts. The pumping station is located to the east of the airport, adjacent to the dual carriageway section of the A453.

Traffic Flows

- 5.5 Based on the existing usage of the cycle networks in the vicinity of EMG1 and the proposed EMG2 site the envisaged usage is predicted to be well below 200 users per hour.

Design Speed and Geometry

- 5.6 The design of the shared facility has been based on LCCs highways design guide and LTN1/20 with particular reference to Chapter 5 'Geometric Requirements'. Where appropriate, DMRB CD 195 has been used to further determine design requirements.
- 5.7 In accordance with LTN1/20, para 5.6.1 and Table 5-4, the design speed for the shared facility is 30kph, increased to 40kph on downhill gradients greater than 3%.
- 5.8 A desirable minimum width of 3.0m is proposed for the shared facility (LTN1/20, para 5.5.1 and Table 5-2), with a short section reduced down to 2.75m as a relaxation due to close proximity to an established hedge on the north side of the A453 and the need to maintain a 1.5m safety margin to the carriageway. We note that the absolute minimum at constraints in LTN1/20 is 2.0m.
- 5.9 A 1.0m verge farthest from the carriageway for the length of the shared facility is proposed adjacent to the dual carriageway section of the A453. The existing verge width is to be retained on the single carriageway section of A453.

- 5.10 A wider than desirable minimum offset of 3.5m is provided along the derestricted dual carriageway section of the A453. An absolute minimum 1.5m adjacent to the 50mph restricted single carriageway section between the Hunter Road and Finger Farm roundabouts in accordance with LTN1/20, Para. ~~6.2.11 and Table 6-1 is proposed except for a pinch point 1.31m as indicated on drawing EMG2-BWB-HGN-A453-DR-H-0101. This constitutes a departure from standard 6.2.11 and Table 6-1.~~
- 5.11 Proposed horizontal curves on the shared facility generally exceed the minimum criteria of 25m and 40m radii for the appropriate design speed as stated within LTN1/20, para. 5.9.1 and Table 5-7 with the exception of the tie in to the existing facility at Hunter Road which has a 20m radius. This constitutes a **relaxation** as LTN 1/20 clause 5.9.3 is not a mandatory requirement. This relaxation is required to enable the shared use footway/cycleway to follow the alignment of the roundabout and minimise third party land requirements and the impact on landscaping adjacent to the hotel.
- 5.12 The section of shared facility from the Finger Farm roundabout heading north for approximately 450m proposes a series of 5% longitudinal gradients for 30m with minimum 5m of flat section (maximum 2%) between each gradient. This is in compliance with LTN1/20, para's: 5.9.7 to 5.9.10 and Table 5-8.
- 5.13 Minimum K Value requirements for sag and crest curves are achieved in accordance with LTN1/20, para. 5.9.5.
- 5.14 The crossfall of the shared facility does not exceed 2.5% in accordance with LTN1/20, para 5.10.1.
- 5.15 It is proposed to maintain the existing vehicular access to the pumping station, a section of which will be shared with the new shared cycle facility. Over this section the existing surfaced access will be retained subject to confirming its current condition. The access track close to the pumping station is proposed to be realigned and include the provision of a new culvert crossing the existing watercourse. The realignment is primarily to provide smooth alignment at the interface with the shared facility and adequate visibility. A new lockable gate close to the pumping station is proposed at the extent of the new adoptable highway boundary. Bollards are proposed at the interfaces both ends of the access track to prevent motorised vehicles entering onto the cycle / pedestrian shared facility. Additional security bollards are proposed at the access of A453 to replace the existing security gate.

Visibility

- 5.16 Stopping sight distance (SSD) along the route is achieved in accordance with LTN1/20, para. 5.7.1 and Table 5-5 (31m for 30kph and 47m for 40kph) with the inclusion of a short section of verge widening on one of the bends within the 40kph section.
- 5.17 A small degree of vegetation clearance may be required at the shared facility junction where the existing and new facilities intersect and at the intersections between the shared facility and the existing access track.

Departures From Standard

~~5.18 There is one **departure from standard** along this section of shared facility as highlighted above.~~

~~5.19 It is recommended that LCC are consulted regarding the proposals for the 5% longitudinal gradient section of the facility.~~

6. HYAM'SHYAMS LANE CYCLE TRACK

Layout

- 6.1 Hyam'sHyams Lane is a cul-de-sac road that serves as highway access for the Old Mill Farm as well as access to fields along the length of Hyam'sHyams Lane.
- 6.2 For the first approximately 120m of Hyam'sHyams Lane from the junction with Grimes Gate, there is a bituminous surface. From this point travelling east Hyam'sHyams Lane becomes a travel track up to the end of the lane near the boundary with the Moto Donington services.
- 6.3 The proposal is to utilise Hyam'sHyams Lane as a cycle track through the EMG2 Main Site including a new section between Hyam'sHyams Lane and Hunter Road roundabout to link the A453 and Diseworth.
- 6.4 It is proposed to provide a bituminous surface for the entire length of Hyam'sHyams Lane to be used as a cycle track, improving the existing gravel surface.

Design Speed and Geometry

- 6.5 The design of the cycle track has been based on LCCs highways design guide and LTN1/20 with particular reference to Chapter 5 'Geometric Requirements'. Where appropriate DMRB CD 195 has been used to further determine design requirements.
- 6.6 In accordance with LTN1/20, para 5.6.1 and Table 5-4, the design speed for the facility is 30kph and 40kph on downhill gradients greater than 3%.
- 6.7 A desirable minimum width of 3.0m is proposed for the section of cycle track currently unsurfaced and to retain the existing minimum 3.7m carriageway width having a bituminous surface.
- 6.8 Proposed horizontal curves for the cycle track generally exceed the minimum criteria of 25m and 40m radii for the appropriate design speed as stated within LTN1/20, para. 5.9.1 and Table 5-7. There are three locations where the minimum radius is not achieved ~~due~~ where the alignment is dictated by the alignment of the adjacent EMG2 Main Site estate road. This constitutes a **relaxation** as LTN 1/20 clause 5.9.3 is not a mandatory requirement.
- 6.9 Minimum K Value requirements for sag and crest curves are achieved in accordance with LTN1/20, para. 5.9.5.
- ~~6.10~~ Longitudinal gradients generally conform to LTN1/20, para. 5.9.7 and Table 5-8. However, there are longitudinal gradients between chainages 750 and 1050 that exceed the length stated on Table 5-8 (**relaxations from standard**). It should be noted that this section is within the existing Hyam'sHyams Lane and is due to the need to retain existing hedgerows and trees along the lane and hence substantial vertical realignment is not possible.

7. L57 FOOTPATH UPGRADE TO CYCLE TRACK

Layout

7.1 Footpath L57 connects Moira Dale in Castle Donington to Diseworth Lane on the western boundary of EMG1. It is a typical unbound footpath running initially along the edge of the playing fields and then through agricultural land.

7.2 The proposal is to upgrade this footpath to a cycle track with a bituminous surface.

Design Speed and Geometry

7.3 The design of the cycle track has been based on LCCs highways design guide and LTN1/20 with particular reference to Chapter 5 'Geometric Requirements'. Where appropriate DMRB CD 195 has been used to further determine design requirements.

7.4 In accordance with LTN1/20, para 5.6.1 and Table 5-4, the design speed for the facility is 30kph and 40kph on downhill gradients greater than 3%.

7.5 A desirable minimum width of 3.0m is proposed for the section cycle track except for the constrained cross-section between the housing at Moira Dale which is to be 2.0m wide.

7.6 Proposed horizontal curves for the cycle track generally exceed the minimum criteria of 25m and 40m radii for the appropriate design speed as stated within LTN1/20, para. 5.9.1 and Table 5-7.

7.7 Minimum K Value requirements for sag and crest curves are achieved in accordance with LTN1/20, para. 5.9.5.

7.8 Longitudinal gradients generally conform to LTN1/20, para. 5.9.7 and Table 5-8. However, there are longitudinal gradients between chainages 200 and 400 that exceed the gradients and length stated on Table 5-8 (**relaxations from standard**). It should be noted that this section is where the footpath crosses an existing watercourse and whilst the levels of the path will be raised by approximately 1m at the lowest point, it would be a substantial piece of engineering to provide an alignment that meets LTN1/20 which would be visually intrusive and out of keeping with the rest of the route.



VIEWPORT VP-01

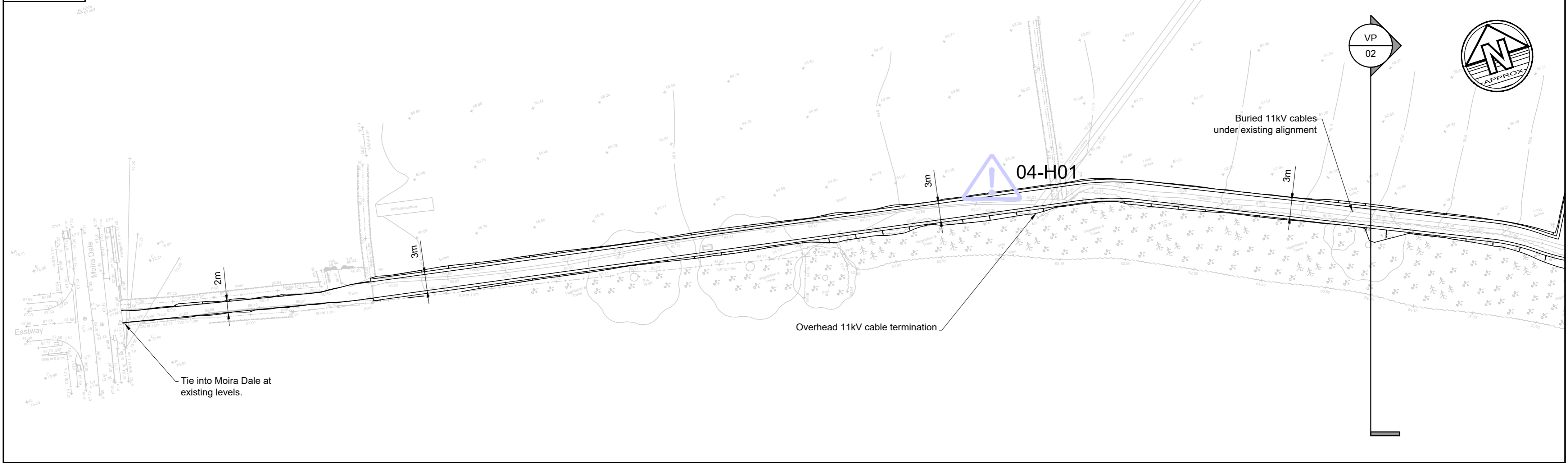

VIEWPORT VP-02

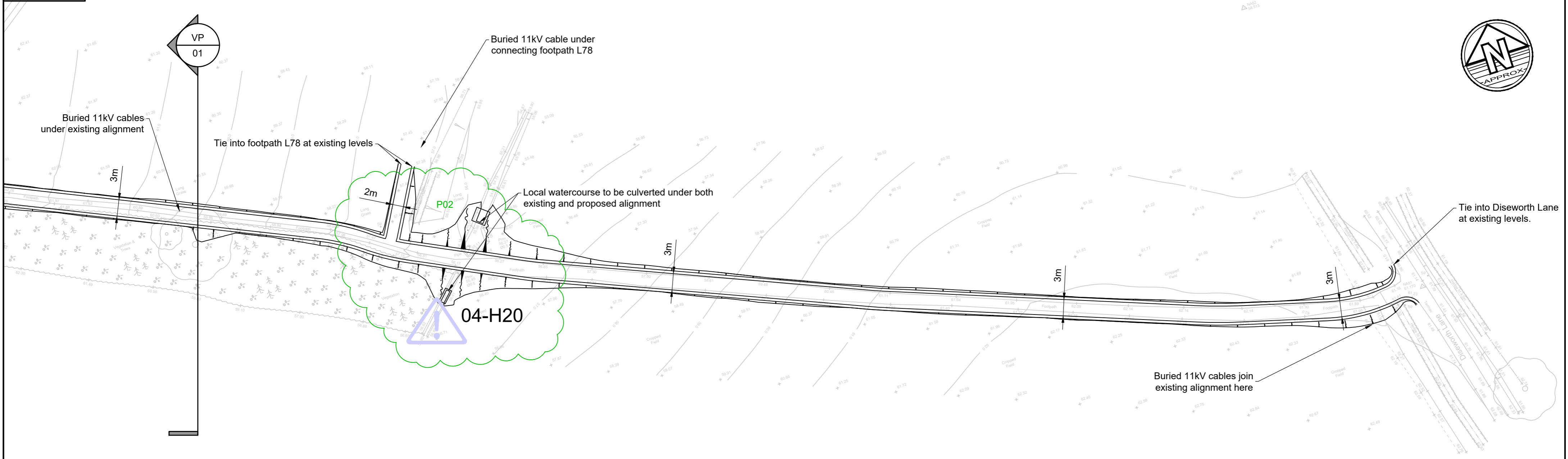

Notes

- Do not scale this drawing. All dimensions must be checked/verified on site. If in doubt ask.
- This drawing is to be read in conjunction with all relevant architects, engineers and specialists drawings and specifications.
- All dimensions in metres unless noted otherwise. All levels in metres unless noted otherwise.
- Any discrepancies noted on site are to be reported to the engineer immediately.

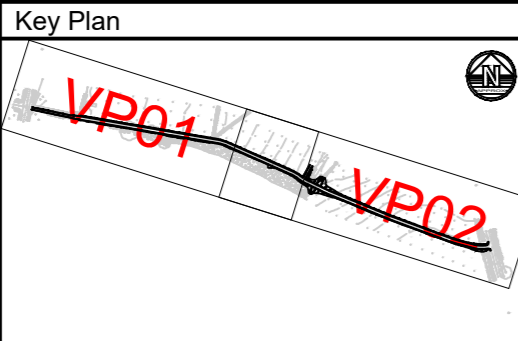

Legend

Hazards

04-HXX

Significant Construction Hazard. To be read in conjunction with, EMG2-BWB-HGN-04-SH-H-0100_L57 Footpath DRA

Issues & Revisions

Rev	Date	Details of issue / revision	Drw	Rev
P01	14.01.25	Preliminary Issue	JB	RAL
P02	12.02.25	L78 Link modified, Earthworks modified, Headwalls now shown.	JB	RAL

BWB
A CAF GROUP COMPANY

- Birmingham | 0121 233 3322
- Leeds | 0113 233 8000
- London | 020 7234 9122
- Manchester | 0161 233 4260
- Nottingham | 0115 924 1100

www.bwbconsulting.com

Client

SEGRO

Drawn: J. Bethell | Reviewed: R. Leyland
BWB Ref: 233445 | Date: 14.01.25 | Scale@A2: 1:500

Project Title

EAST MIDLANDS GATEWAY 2 L57 FOOTPATH

Drawing Status

PRELIMINARY

Drawing Title

GENERAL ARRANGEMENT LAYOUT

Project - Originator - Zone - Level - Type - Role - Number | Status | Rev

EMG2-BWB-HGN-04-DR-H-0100 | S3 | P02



El Sub Sta

Hotel

Hotel

El Sub Sta

DMRB CD 109
Highway link design

DMRB CD 116
Roundabout design

DMRB Ref. CD109
Table 2.5
85 Kph Design Speed

CD116 Para 3.17.1
Average entry min flare length should be 25m in Rural areas. However capacity can determine length. >100m changes std to CD109.

DMRB Ref. CD116
Para 3.14.2
Lane width should be >3m, <3.5m for multi lane entries.
DMRB Ref. CD116
Para 3.14
Lane width shall be >3m, <4.5m for multi lane entries.

DMRB Ref. CD116
Para 3.19
Entry kerb radius >10m, <100m (Best fit circular curve over 25m from giveaway.)

DMRB Ref. CD116
Para 3.6
Max circulatory width 1.2 x max entry width. 8.9*1.2=10.68m

DMRB Ref. CD116
Para 3.18.2
Projected kerb tangential to central island

CD116 Para 3.18
Note 3, 3.18.1
Entry angle should be between 20° & 60°

DMRB Ref. CD116
Para 3.12
Entry width for single carriageway approach <10.5m

CD116 Para 3.26
Entry path radius shall not exceed 100m

DMRB Ref. CD116
Para 3.28.3
Exit width reduction taper 1:20

DMRB Ref. CD116
Para 3.28.2
Exit width 7-7.5m for single carriageway downstream link

CD116 Para 3.29.3
Exit kerb radius should be between 20m & 100m

DMRB Ref. CD116
Para 3.18.2
Projected kerb tangential to central island

CD116 Para 3.18
Note 3, 3.18.1
Entry angle should be between 20° & 60°

DMRB Ref. CD116
Para 3.19
Entry kerb radius >10m, <100m (Best fit circular curve over 25m from giveaway.)

DMRB Ref. CD116
Para 3.14.2
Lane width should be >3m, <3.5m for multi lane entries.
DMRB Ref. CD116
Para 3.14
Lane width shall be >3m, <4.5m for multi lane entries.

CD116 Para 3.26
Entry path radius shall not exceed 100m

LTN 1-20 Tab 5.4
Design Speed 30kph

DMRB Ref. CD116
Para 3.19
Entry kerb radius >10m, <100m (Best fit circular curve over 25m from giveaway.)

CD116 Para 3.29.3
Exit kerb radius should be between 20m & 100m

LTN 1/20, Tab 6-1
Separation from the carriageway Desirable = 2.0m Min = 1.5m

DMRB Ref. CD116
Para 3.28.2
Exit width 7-7.5m for single carriageway downstream link

DMRB Ref. CD116
Para 3.28.3
Exit width reduction taper 1:20

DMRB Ref. CD116
Para 3.28.3
Exit width reduction taper 1:45

LTN 1-20
Table 5.7
30 Kph Design Speed
Min radius = 25m

DMRB CD 109
Highway link design

LTN 1/20, Tab 6-1
Separation from the carriageway Desirable = 2.0m Min = 1.5m

DMRB Ref. CD43
Para E/3.5
Widths of unsegregated shared use routes Min = 2.0m

CD 143, Para. E/3.5.1
Separation from the carriageway Min. 1.5m

DMRB Ref. CD116 Para 3.14
Lane width >3m, <4.5m for multi lane entries

CD116 Para 3.26
Entry path radius shall not exceed 100m

CD116 Para 3.17.1
Average entry min flare length should be 25m in Rural areas. However capacity can determine length. >100m changes std to CD109.

DMRB Ref. CD116
Para 3.19
Entry kerb radius >10m, <100m (Best fit circular curve over 25m from giveaway.)

DMRB Ref. CD116
Para 3.14.2
Lane width should be >3m, <3.5m for multi lane entries.
DMRB Ref. CD116
Para 3.14
Lane width shall be >3m, <4.5m for multi lane entries.

LTN 1-20
Table 5.7
30 Kph Design Speed
Min radius = 25m

CD116 Para 3.18
Note 3, 3.18.1
Entry angle should be between 20° & 60°

CD116 Para 3.29.3
Exit kerb radius should be between 20m & 100m

CD116 Para 3.3, 3.5.2
ICD of a normal roundabout should not exceed 100m

DMRB Ref. CD116
Para 3.28.2
Exit width 7-7.5m for single carriageway downstream link

CD123 Para 7.10
Dedicated turning lane taper 1:5

CD116 Para 3.17.1
Average entry min flare length should be 25m in Rural areas. However capacity can determine length. >100m changes std to CD109.

Culline - See Sheet 2

Notes	
1. Do not scale this drawing. All dimensions must be checked/verified on site. If in doubt ask.	7. Annotation shown coloured red is a departure from design standards
2. This drawing is to be read in conjunction with all relevant architects, engineers and specialists drawings and specifications.	
3. All dimensions in metres unless noted otherwise. All levels in metres unless noted otherwise.	
4. Any discrepancies noted on site are to be reported to the engineer immediately.	
5. Annotation shown coloured green achieves design standards	
6. Annotation shown coloured amber is a relaxation from design standards	

Legend	
	Draft Order Limits
	Alignment - Straights
	Alignment - Curves
	Alignment - Transitions
	Carriageway area
	Taper for cross section width change

ISSUES & REVISIONS					
Rev	Date	Details of issue / revision	MS	SRH	DF
P01	14.05.25	Issue for information	MS	SRH	
P02	11.07.25	Updated following LCC comments	SRH	SRH	
P03	10.02.26	Updated for departure submission	DF	SRH	
P04	05.03.26	Footway departure removed	DF	SRH	

BWB
A CAF GROUP COMPANY

Birmingham | 0121 233 3322
 Leeds | 0113 233 8000
 London | 020 7234 9122
 Manchester | 0161 233 4260
 Nottingham | 0115 924 1100
www.bwbconsulting.com

Client

SEGRO

Drawn: M.Stockton Reviewed: S.Hilditch
 B/WB Ref: 220500 Date: 10.12.24 Scale@A1: 1:500

Project Title

East Midlands Gateway 2

Drawing Status

FOR INFORMATION

Drawing Title

**A453
Geometry Plans
Sheet 1 of 4**

Project - Originator - Zone - Level - Type - Role - Number Status Rev

EMG2-BWB-HGN-A453-DR-H-0101 S2 P04

© Crown copyright and database rights 2025 OS 0100023343



Cutline - See Sheet 3

LTN 1-20 Tab 5.4
Design Speed 40kph
(Downward gradient >3%)

LTN 1-20 Table 5.7
40 Kph Design Speed
Min radius = 40m

LTN 1-20 Table 5.7
40 Kph Design Speed
Min radius = 40m

LTN 1-20 Tab 5.4
Design Speed 30kph

LTN 1-20 Tab 5.4
Design Speed 40kph
(Downward gradient >3%)

LTN 1-20 Tab 5.4
Design Speed 30kph

DMRB Ref. CD43
Para E/3.5
Widths of
unsegregated
shared use routes
Min = 2.0m

LTN 1/20, Tab 6-1
Separation from the
carriageway
Desirable = 2.0m
Min = 1.5m

LTN 1-20 Table 5.7
30 Kph Design Speed
Min radius = 25m

LTN 1-20 Table 5.7
30 Kph Design Speed
Min radius = 25m

LTN 1-20 Table 5.7
30 Kph Design Speed
Min radius = 25m

Existing island &
widening for ADS
signage to remain.

Note: Existing pumping
station access to be
reviewed during detailed
design

Cycle Route 15
(Section A)

Cycle Route 15
(Section B)

Cycle Route 15
(Section A)

LTN 1/20, Tab 6-1
Separation from the
carriageway
Desirable = 2.0m
Min = 1.5m

DMRB Ref. CD116
Para 3.28.3
Exit width reduction
taper 1:20 min

CD116 Para 3.29.3
Exit kerb radius should
be between 20m & 100m

DMRB Ref. CD109
Table 2.5
85 Kph Design Speed

DMRB CD 109
Highway link design

DMRB CD 116
Roundabout design

DMRB CD 116
Roundabout design

DMRB CD 109
Highway link design

Finger
Farm Rbt

© Crown copyright and database rights 2025 OS 0100023343

Notes

- Do not scale this drawing. All dimensions must be checked/verified on site. If in doubt ask.
- This drawing is to be read in conjunction with all relevant architects, engineers and specialists drawings and specifications.
- All dimensions in metres unless noted otherwise. All levels in metres unless noted otherwise.
- Any discrepancies noted on site are to be reported to the engineer immediately.
- Annotation shown coloured green achieves design standards
- Annotation shown coloured amber is a relaxation from design standards
- Annotation shown coloured red is a departure from design standards

Legend

- Draft Order Limits
- Alignment - Straights
- Alignment - Curves
- Alignment - Transitions
- Carriageway area
- Taper for cross section width change

ISSUES & REVISIONS

Rev	Date	Details of issue / revision	Drw	Rev
P01	14.05.25	Issue for information	MS	SRH
P02	11.07.25	Updated following LCC comments	SRH	SRH
P03	10.02.26	Updated for departure submission	DF	SRH
P04	05.03.26	Footway departure removed	DF	SRH

BWB
A CAP GROUP COMPANY

Birmingham | 0121 233 3322
 Leeds | 0113 233 8000
 London | 020 7234 9122
 Manchester | 0161 233 4260
 Nottingham | 0115 924 1100
 www.bwbconsulting.com

Client

SEGRO

Drawn: M.Stockton
 B/WB Ref: 220500
 Reviewed: S.Hilditch
 Date: 10.12.24
 Scale@A1: 1:500

Project Title

East Midlands Gateway 2

Drawing Status

FOR INFORMATION

Drawing Title

**A453
Geometry Plans
Sheet 2 of 4**

Project - Originator - Zone - Level - Type - Role - Number

EMG2-BWB-HGN-A453-DR-H-0102

Status Rev

S2 P04

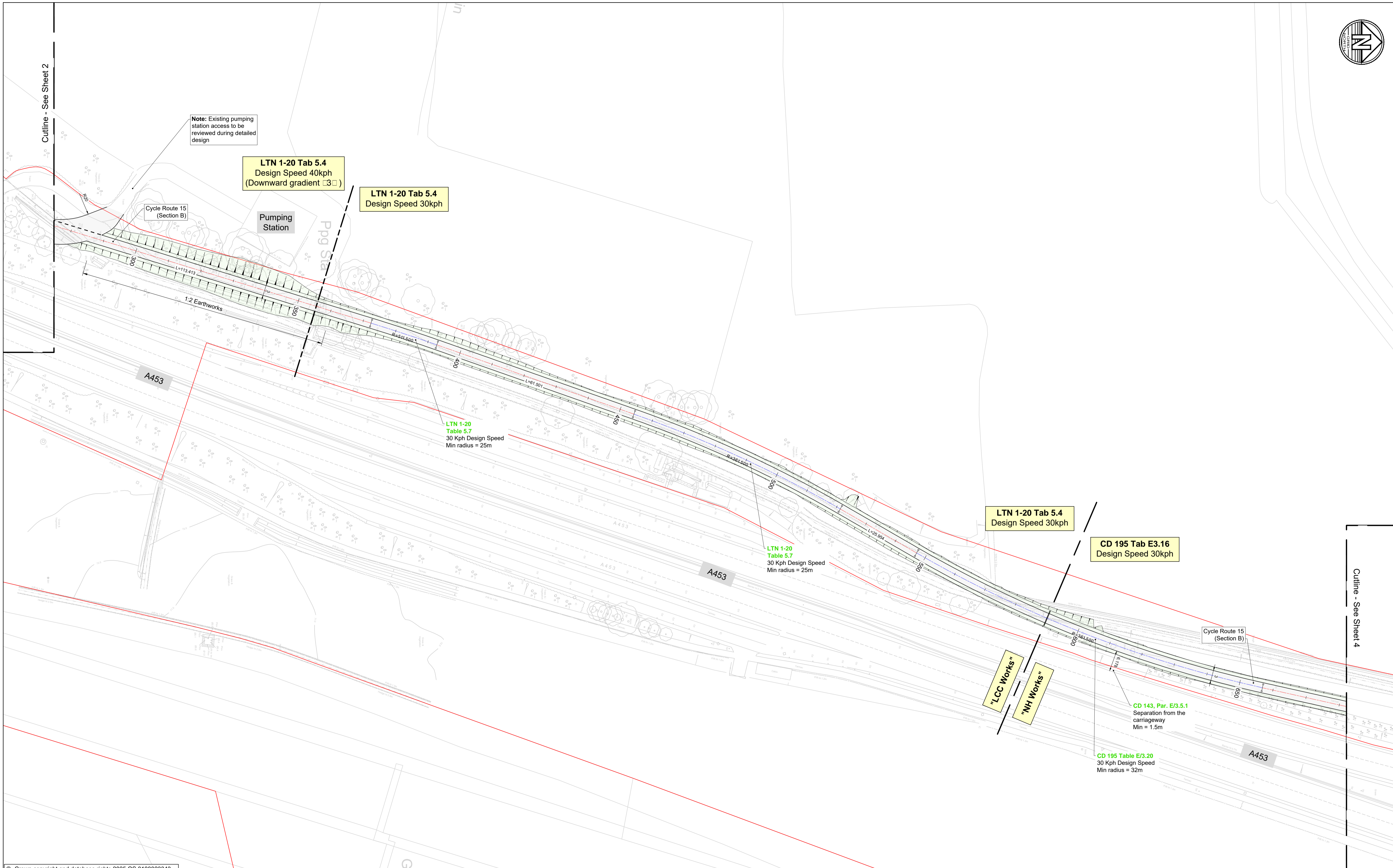
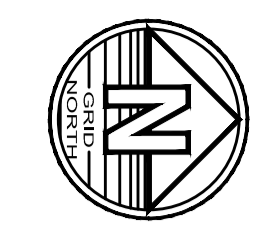

© Crown copyright and database rights 2025 OS 0100023343

Notes

- Do not scale this drawing. All dimensions must be checked/verified on site. If in doubt ask.
- This drawing is to be read in conjunction with all relevant architects, engineers and specialists drawings and specifications.
- All dimensions in metres unless noted otherwise. All levels in metres unless noted otherwise.
- Any discrepancies noted on site are to be reported to the engineer immediately.
- Annotation shown coloured green achieves design standards
- Annotation shown coloured amber is a relaxation from design standards
- Annotation shown coloured red is a departure from design standards

Legend

- Draft Order Limits
- Alignment - Straights
- Alignment - Curves
- Alignment - Transitions
- Carriageway area
- Taper for cross section width change

ISSUES & REVISIONS

Rev	Date	Details of issue / revision	Drw	Rev
P01	04.03.25	Issue for information	MS	SH
P02	15.05.25	Minor annotation changes	MS	SH

BWB
A CAF GROUP COMPANY

- Birmingham | 0121 233 3322
- Leeds | 0113 233 8000
- London | 020 7234 9122
- Manchester | 0161 233 4260
- Nottingham | 0115 924 1100
- www.bwbconsulting.com

Client

SEGRO

Drawn: M.S | Reviewed: S.H
 Date: 04.03.25 | Scale@A1: 1:500

Project Title

East Midlands Gateway 2

Drawing Status

FOR INFORMATION

Drawing Title

**A453
Geometry Plans
Sheet 3 of 4**

Project - Originator - Zone - Level - Type - Role - Number

EMG2-BWB-HGN-A453-DR-H-0103

Status **S2** | Rev **P02**

© Copyright BWB Consulting Ltd



Main plan shows the 16.5m CD 116 design vehicle and large car

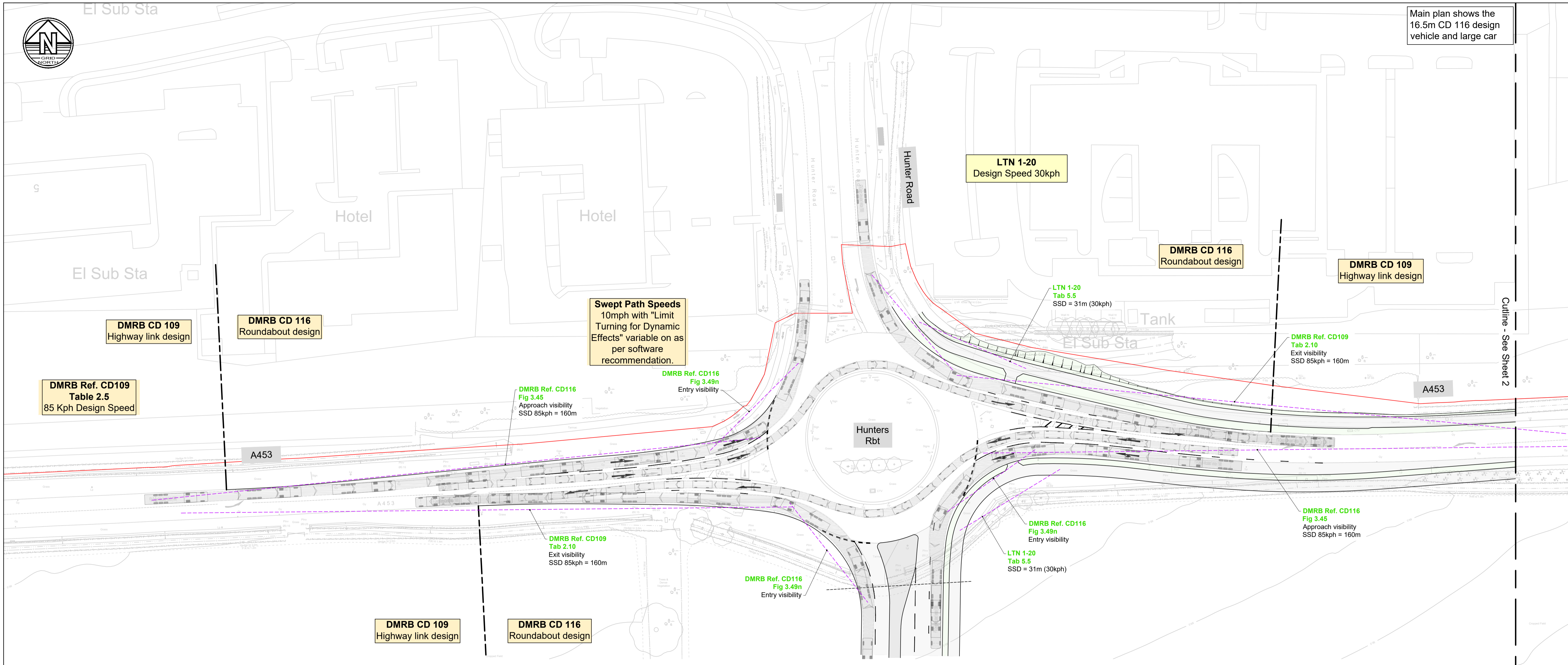

Swept Path Speeds 10mph with "Limit Turning for Dynamic Effects" variable on as per software recommendation.

DMRB Ref. CD109 Table 2.5 85 Kph Design Speed

DMRB CD 109 Highway link design

DMRB CD 116 Roundabout design

LTN 1-20 Design Speed 30kph

DMRB CD 116 Roundabout design

DMRB CD 109 Highway link design

DMRB Ref. CD116 Fig 3.45 Approach visibility SSD 85kph = 160m

DMRB Ref. CD116 Fig 3.49n Entry visibility

LTN 1-20 Tab 5.5 SSD = 31m (30kph)

DMRB Ref. CD109 Tab 2.10 Exit visibility SSD 85kph = 160m

DMRB Ref. CD109 Tab 2.10 Exit visibility SSD 85kph = 160m

DMRB Ref. CD116 Fig 3.49n Entry visibility

DMRB Ref. CD116 Fig 3.49n Entry visibility

LTN 1-20 Tab 5.5 SSD = 31m (30kph)

DMRB Ref. CD116 Fig 3.45 Approach visibility SSD 85kph = 160m

DMRB CD 109 Highway link design

DMRB CD 116 Roundabout design

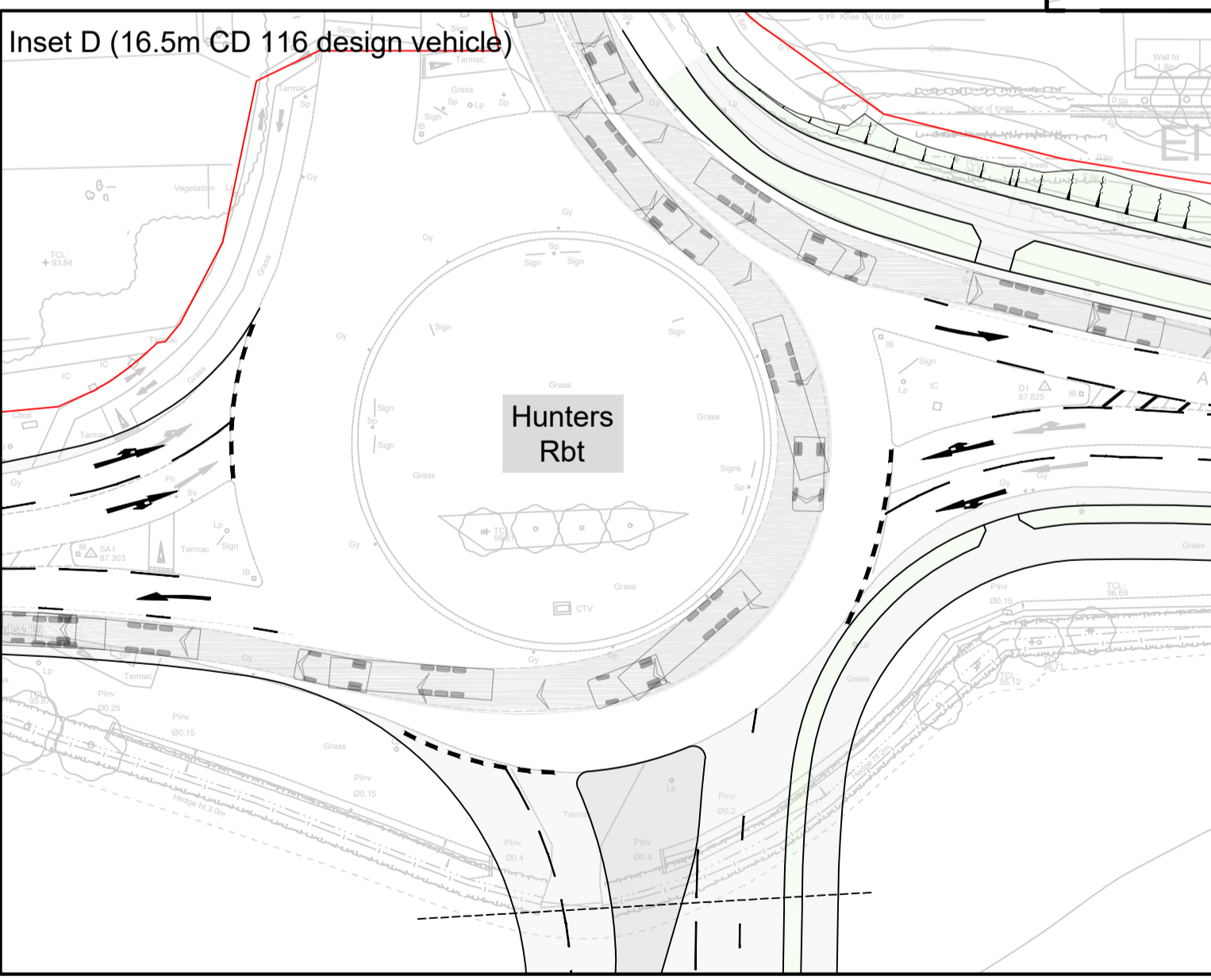
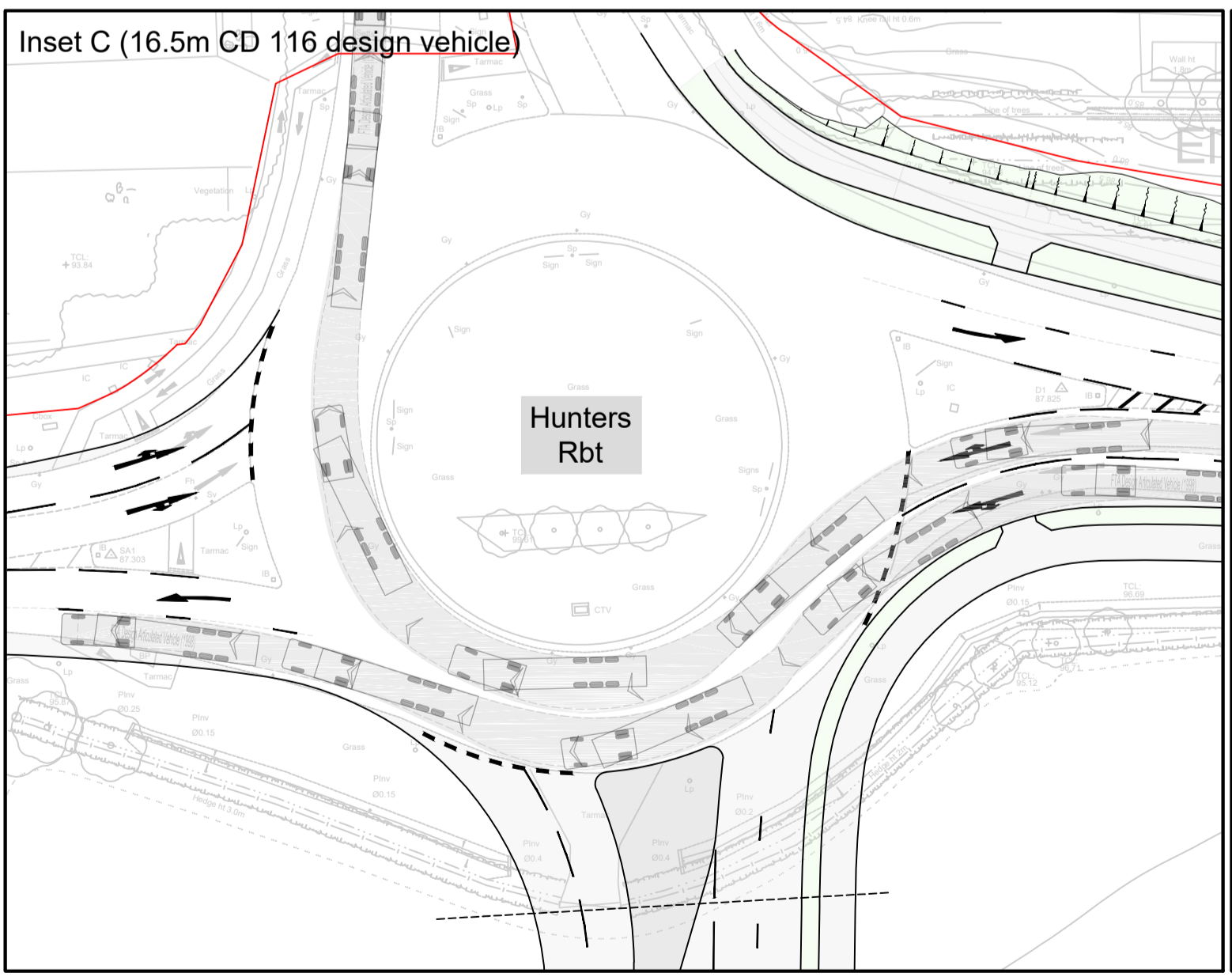
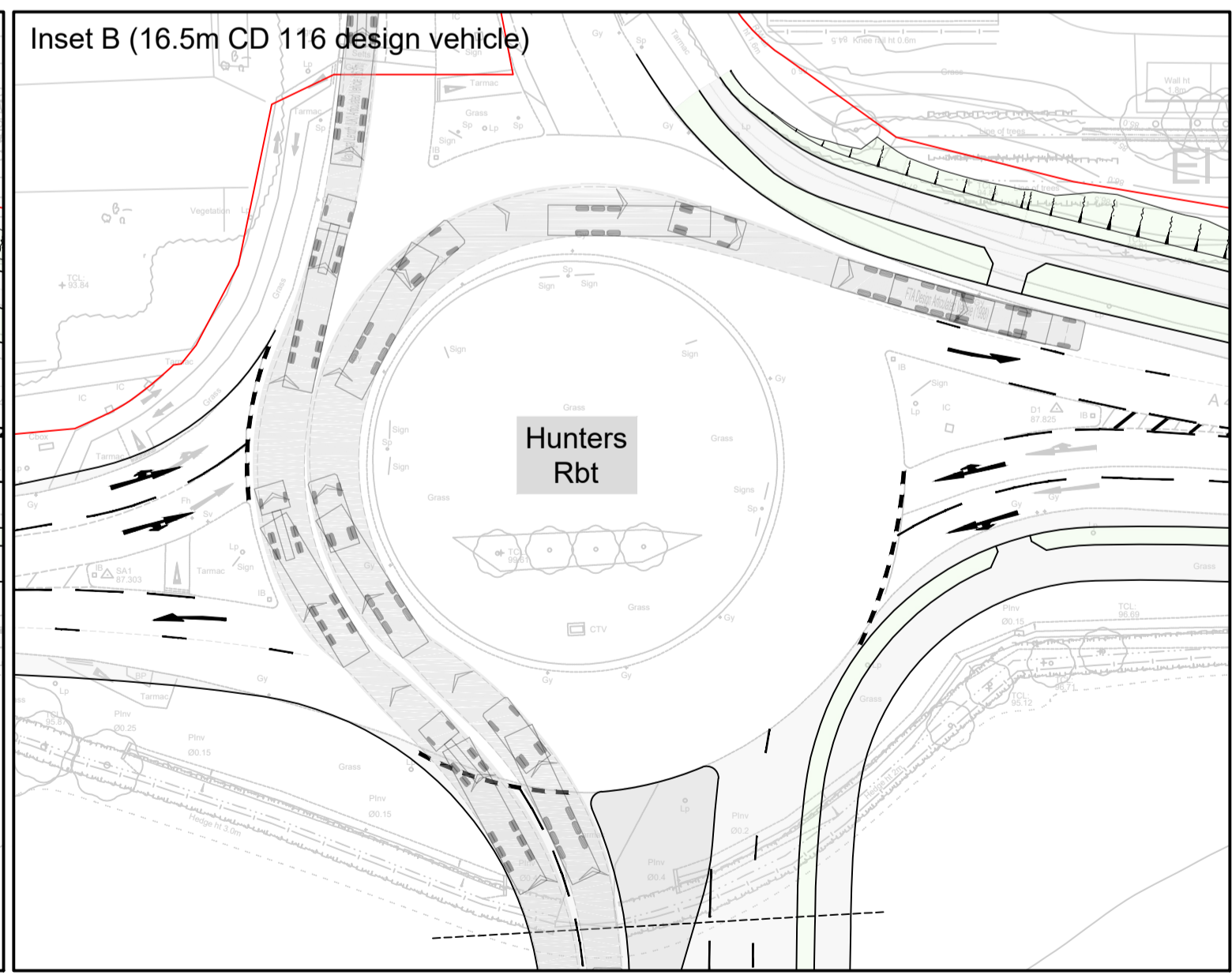
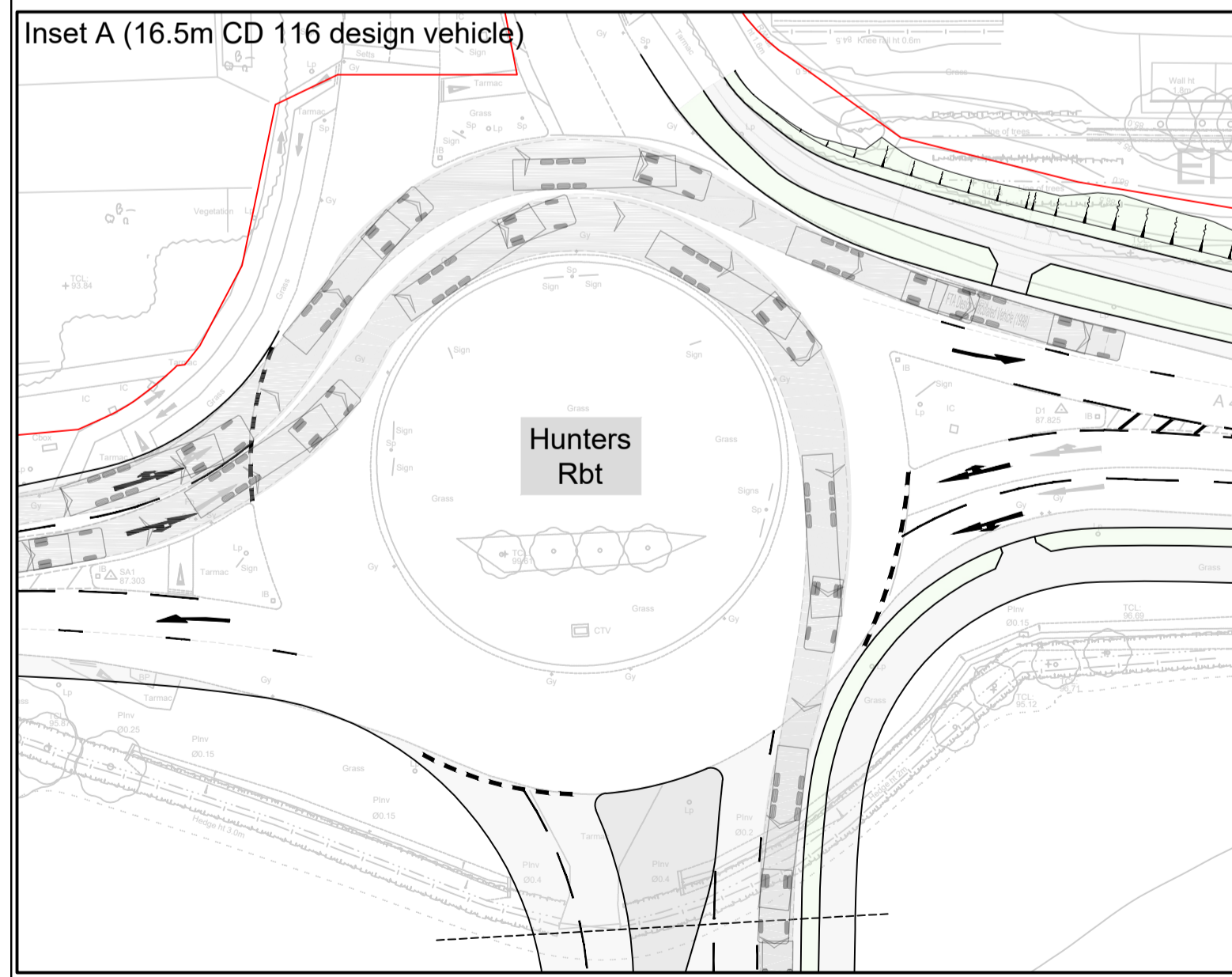

Notes: 1. Do not scale this drawing. All dimensions must be checked/verified on site. If in doubt ask. 2. This drawing is to be read in conjunction with all relevant architects, engineers and specialists drawings and specifications. 3. All dimensions in metres unless noted otherwise. All levels in metres unless noted otherwise. 4. Any discrepancies noted on site are to be reported to the engineer immediately. 5. Visibility sight lines shown are in plan view only. These are to be checked vertically against the design / existing surfaces at detailed design stage.

Legend table with symbols for road types, visibility lines, and design standards.

ISSUES & REVISIONS table with columns for Rev, Date, Details of issue / revision, Drw, Rev.

BWB logo and contact information for Birmingham, Leeds, London, and Manchester.

SEGRO logo and client information.

Project Title: East Midlands Gateway 2. Drawing Status: FOR INFORMATION.

Drawing Title: A453 Vehicle Swept Paths & Visibility Sheet 1 of 4. Project - Originator - Zone - Level - Type - Role - Number: EMG2-BWB-HGN-A453-DR-H-0110. Status: S2. Rev: P05.



Main plan shows the 18.5m articulated vehicle and large car

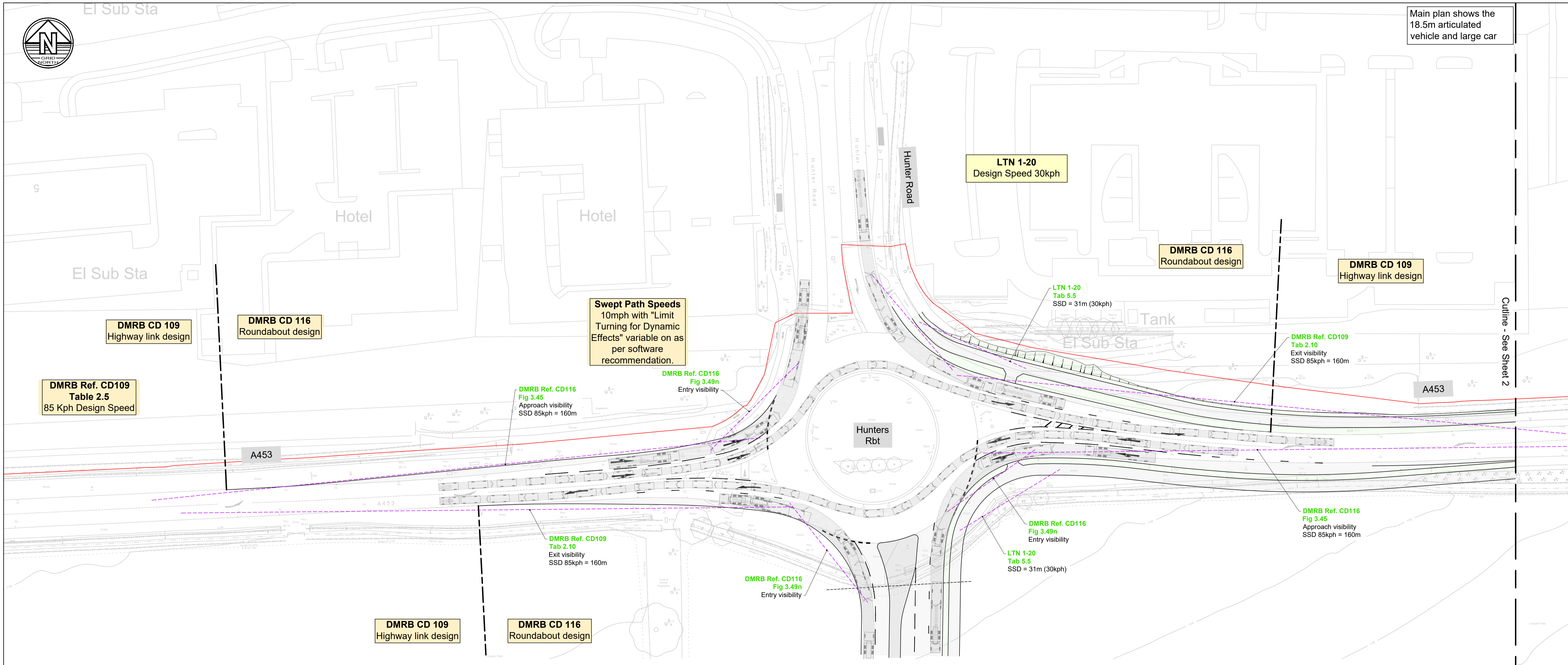

Swept Path Speeds
10mph with "Limit Turning for Dynamic Effects" variable on as per software recommendation.

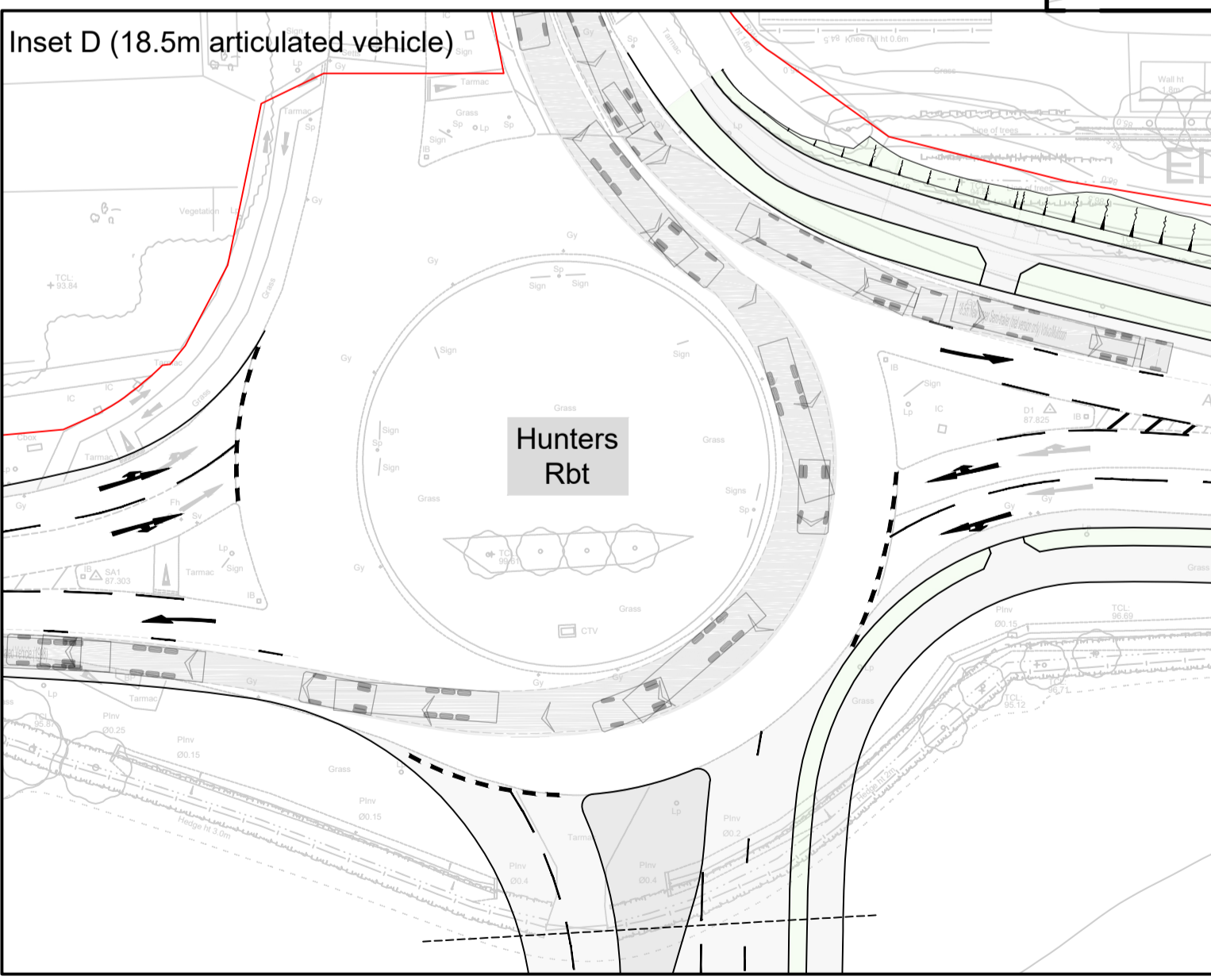
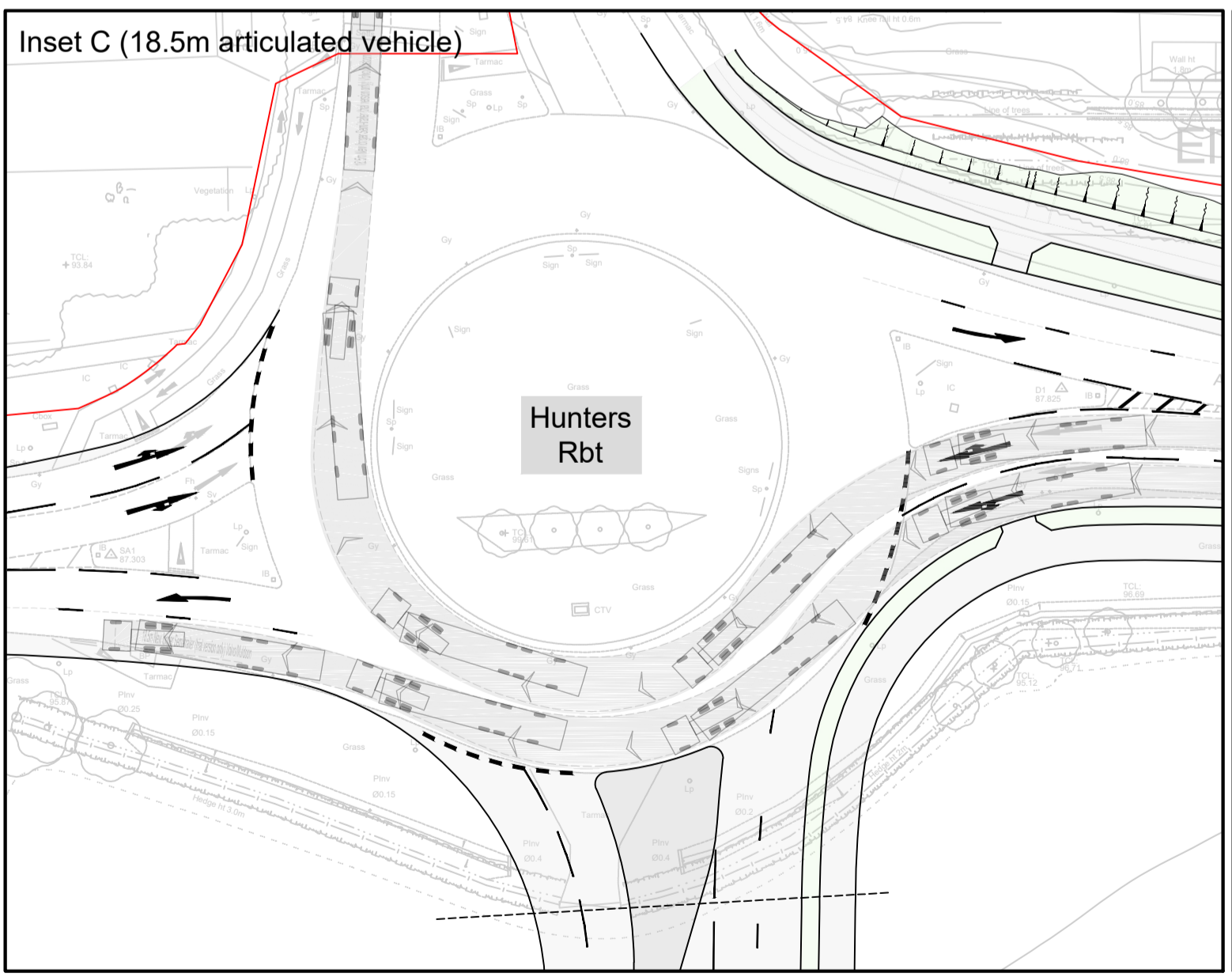
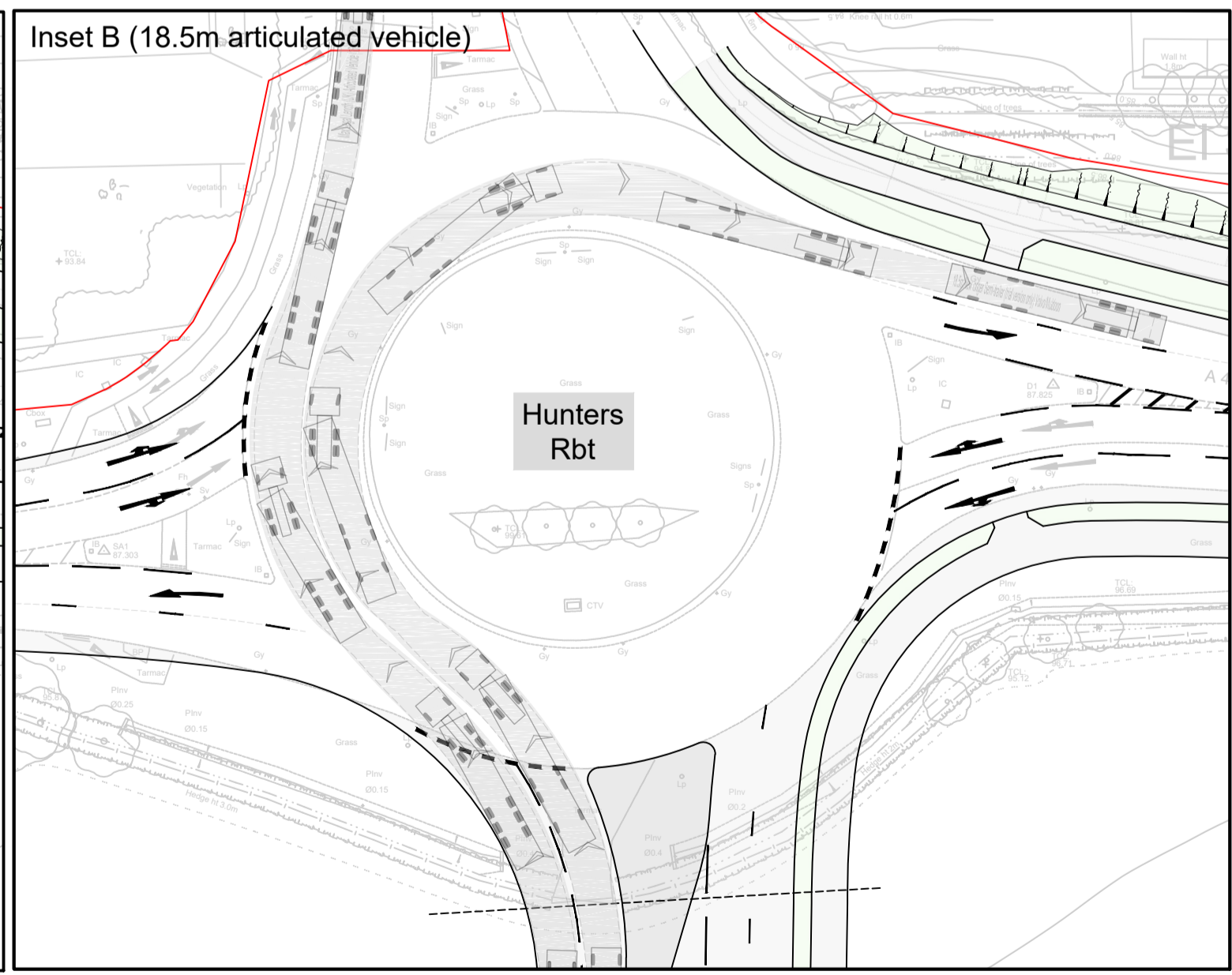
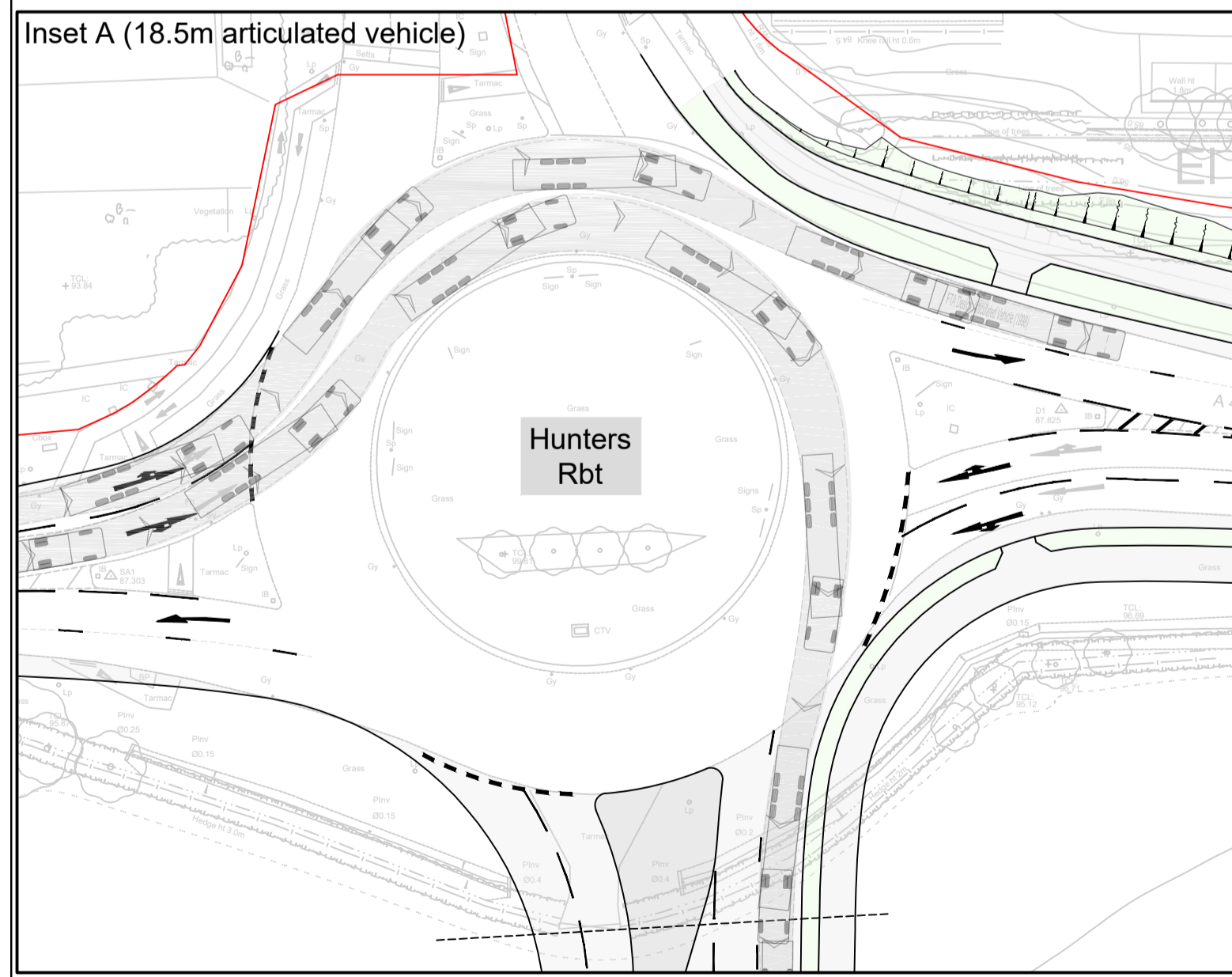

Notes

- Do not scale this drawing. All dimensions must be checked/ verified on site. If in doubt ask.
- This drawing is to be read in conjunction with all relevant architects, engineers and specialists drawings and specifications.
- All dimensions in metres unless noted otherwise. All levels in metres unless noted otherwise.
- Any discrepancies noted on site are to be reported to the engineer immediately.
- Visibility sight lines shown are in plan view only. These are to be checked vertically against the design / existing surfaces at detailed design stage.

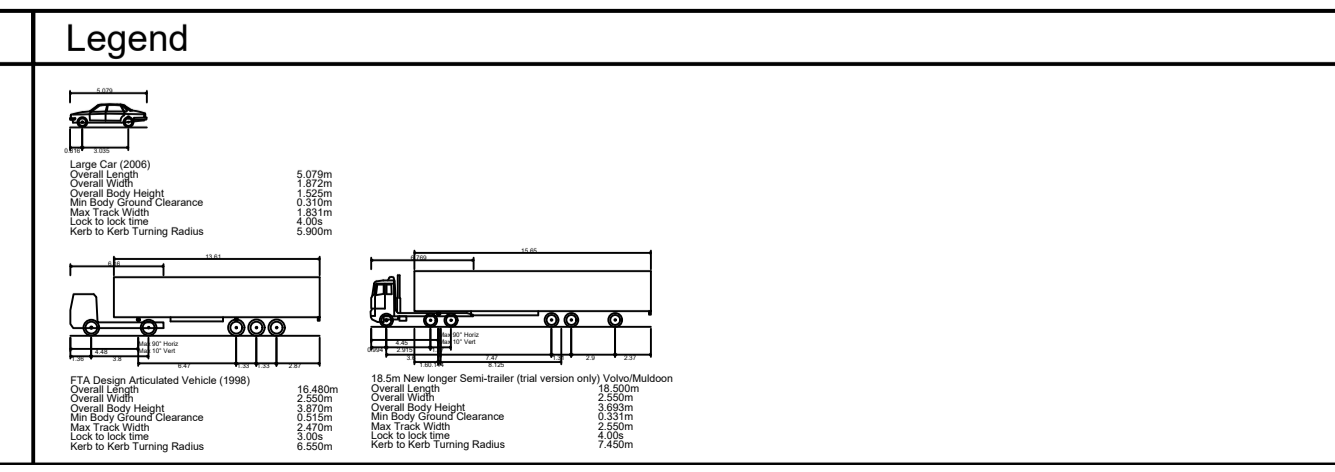

ISSUES & REVISIONS

Rev	Date	Details of issue / revision	Drw	Rev
P01	03.03.26	Issue for information	DF	SH
P02	05.03.26	Issue for information	DF	SH

BWB
A CAF GROUP COMPANY

Birmingham | 0121 233 3322
 Leeds | 0113 233 8000
 London | 020 7234 9122
 Manchester | 0161 233 4260
 Nottingham | 0115 924 1100
www.bwbconsulting.com

Client

SEGRO

Drawn: D.Fraser
 Date: 03.03.26
 Reviewed: S.Hilditch
 Scale@A1: 1:500

Project Title

East Midlands Gateway 2

Drawing Status

FOR INFORMATION

Drawing Title

**A453
Vehicle Swept Paths &
Visibility (18.5m artic)
Sheet 1a of 4**

Project - Originator - Zone - Level - Type - Role - Number

EMG2-BWB-HGN-A453-DR-H-0110a

Status Rev

S2 P02



Inset A (18.5m articulated vehicle)

Cutline - See Sheet 3

LTN 1-20
Design Speed 40kph

Swept Path Speeds
30mph with "Limit
Turning for Dynamic
Effects" variable on as
per software
recommendation.

LTN 1-20
Tab 5.5
SSD = 47m (40kph)

Gas Gov

Hotel

ED & J

Def

LTN 1-20
Design Speed 30kph

LTN 1-20
Design Speed 40kph

LTN 1-20
Design Speed 30kph

A453

A453

A453

A453

A453

A453

DMRB Ref. CD109
Tab 2.10
Existing SSD = 60m
Actual SSD = 80m
SSD 85kph = 160m Desirable min.
(This is an existing departure)
Vegetation to be trimmed back to maximise
visibility at the exit

DMRB Ref. CD109
Table 2.5
85 Kph Design Speed

DMRB Ref. CD109
Tab 2.10
SSD 85kph = 160m Desirable min.
(Point at which required visibility is
achieved.)

Swept Path Speeds
30mph with "Limit
Turning for Dynamic
Effects" variable on as
per software
recommendation.

DMRB CD 116
Roundabout design

DMRB CD 109
Highway link design

DMRB CD 109
Highway link design

DMRB CD 116
Roundabout design

Finger
Farm Rbt

© Crown copyright and database rights 2025 OS 0100023343

Notes

- Do not scale this drawing. All dimensions must be checked/verified on site. If in doubt ask.
- This drawing is to be read in conjunction with all relevant architects, engineers and specialists drawings and specifications.
- All dimensions in metres unless noted otherwise. All levels in metres unless noted otherwise.
- Any discrepancies noted on site are to be reported to the engineer immediately.
- Visibility sight lines shown are in plan view only. These are to be checked vertically against the design / existing surfaces at detailed design stage.

© Copyright BWB Consulting Ltd

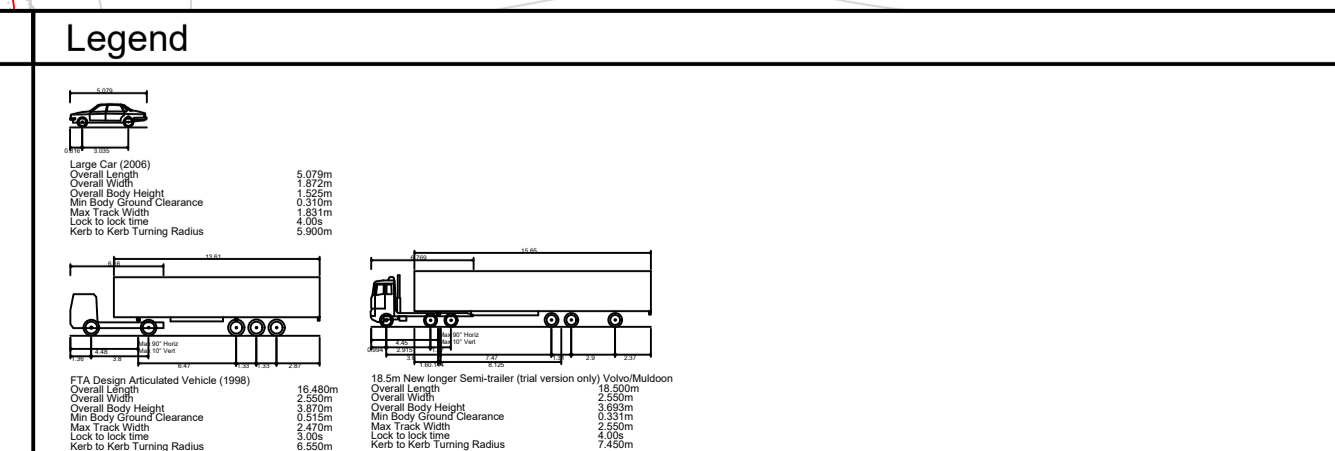

ISSUES & REVISIONS

Rev	Date	Details of issue / revision	Drw	Rev
P01	14.05.25	Issue for information	MS	SH
P02	11.07.25	Inserts A and B added for additional tracks	MS	SH
P03	10.02.26	Tracking updated following RSA 1	DF	SH
P04	05.03.26	18.5m Articulated tracking added	DF	SH

BWB
A CAF GROUP COMPANY

Birmingham | 0121 233 3322
 Leeds | 0113 233 8000
 London | 020 7234 9122
 Manchester | 0161 233 4260
 Nottingham | 0115 924 1100
www.bwbconsulting.com

Client

SEGRO

Drawn: M.Stockton
 Reviewed: S.Hilditch
 Date: 05.06.25
 Scale@A1: 1:500

Project Title

East Midlands Gateway 2

Drawing Status

FOR INFORMATION

Drawing Title

**A453
Vehicle Swept Paths &
Visibility
Sheet 2 of 4**

Project - Originator - Zone - Level - Type - Role - Number

EMG2-BWB-HGN-A453-DR-H-0111

Status Rev

S2 P04

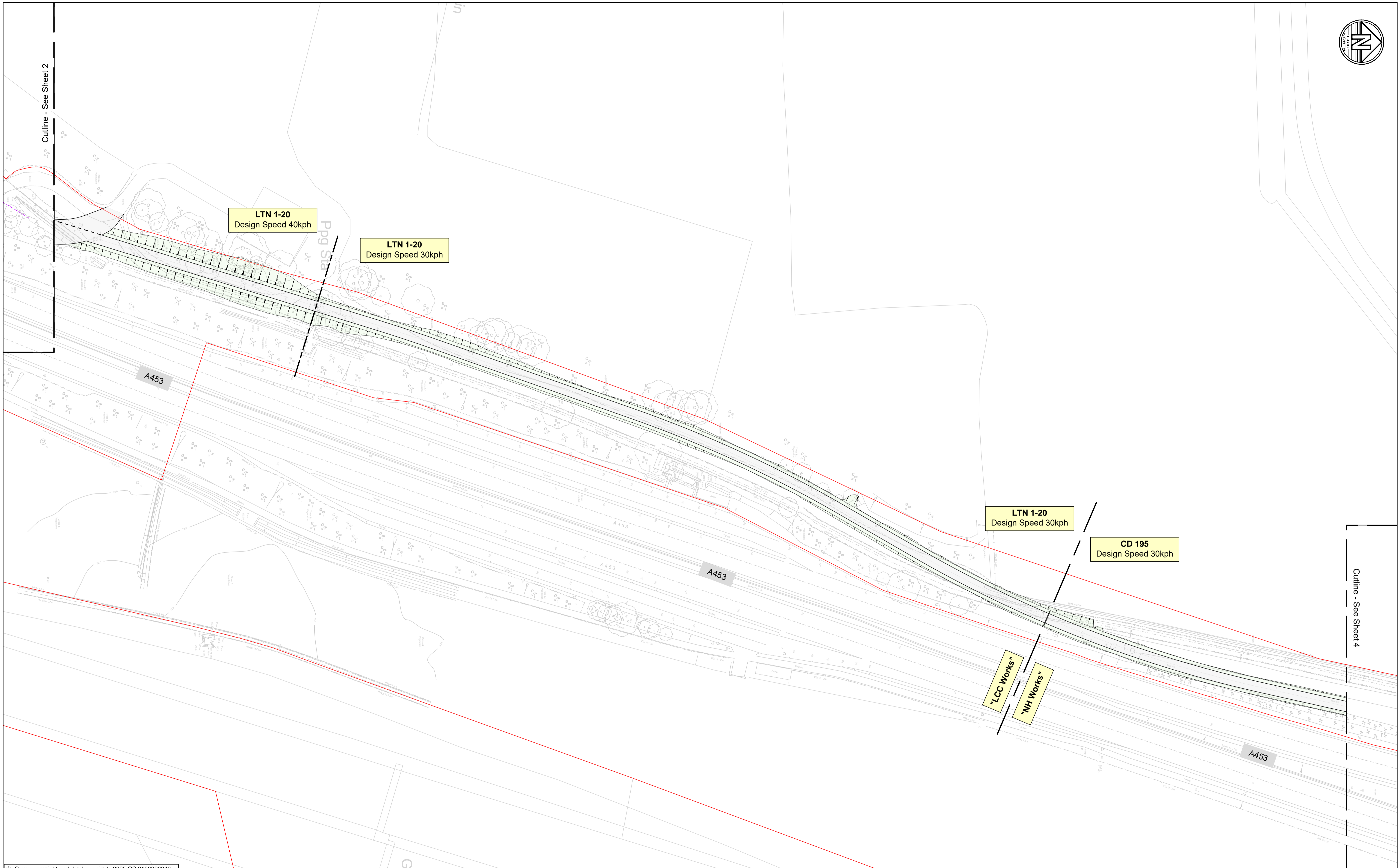
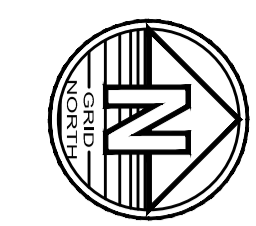

Cutline - See Sheet 2

Cutline - See Sheet 4

© Crown copyright and database rights 2025 OS 0100023343

Notes

- Do not scale this drawing. All dimensions must be checked/verified on site. If in doubt ask.
- This drawing is to be read in conjunction with all relevant architects, engineers and specialists drawings and specifications.
- All dimensions in metres unless noted otherwise. All levels in metres unless noted otherwise.
- Any discrepancies noted on site are to be reported to the engineer immediately.
- Visibility sight lines shown are in plan view only. These are to be checked vertically against the design / existing surfaces at detailed design stage.

Legend

	LCC Works
	NH Works
	LTN 1-20 Design Speed 40kph
	LTN 1-20 Design Speed 30kph
	CD 195 Design Speed 30kph

ISSUES & REVISIONS

Rev	Date	Details of issue / revision	Drw	Rev
P01	14.05.25	Issue for information	MS	SH

BWB
A CAF GROUP COMPANY

Birmingham | 0121 233 3322
 Leeds | 0113 233 8000
 London | 020 7234 9122
 Manchester | 0161 233 4260
 Nottingham | 0115 924 1100
www.bwbconsulting.com

Client

SEGRO

Drawn: M.S. Reviewed: S.H.
 BWB Ref: 220500 Date: 05.06.25 Scale@A1: 1:500

Project Title

East Midlands Gateway 2

Drawing Status

FOR INFORMATION

Drawing Title

**A453
Vehicle Swept Paths &
Visibility
Sheet 3 of 4**

Project - Originator - Zone - Level - Type - Role - Number	Status	Rev
EMG2-BWB-HGN-A453-DR-H-0112	S2	P01

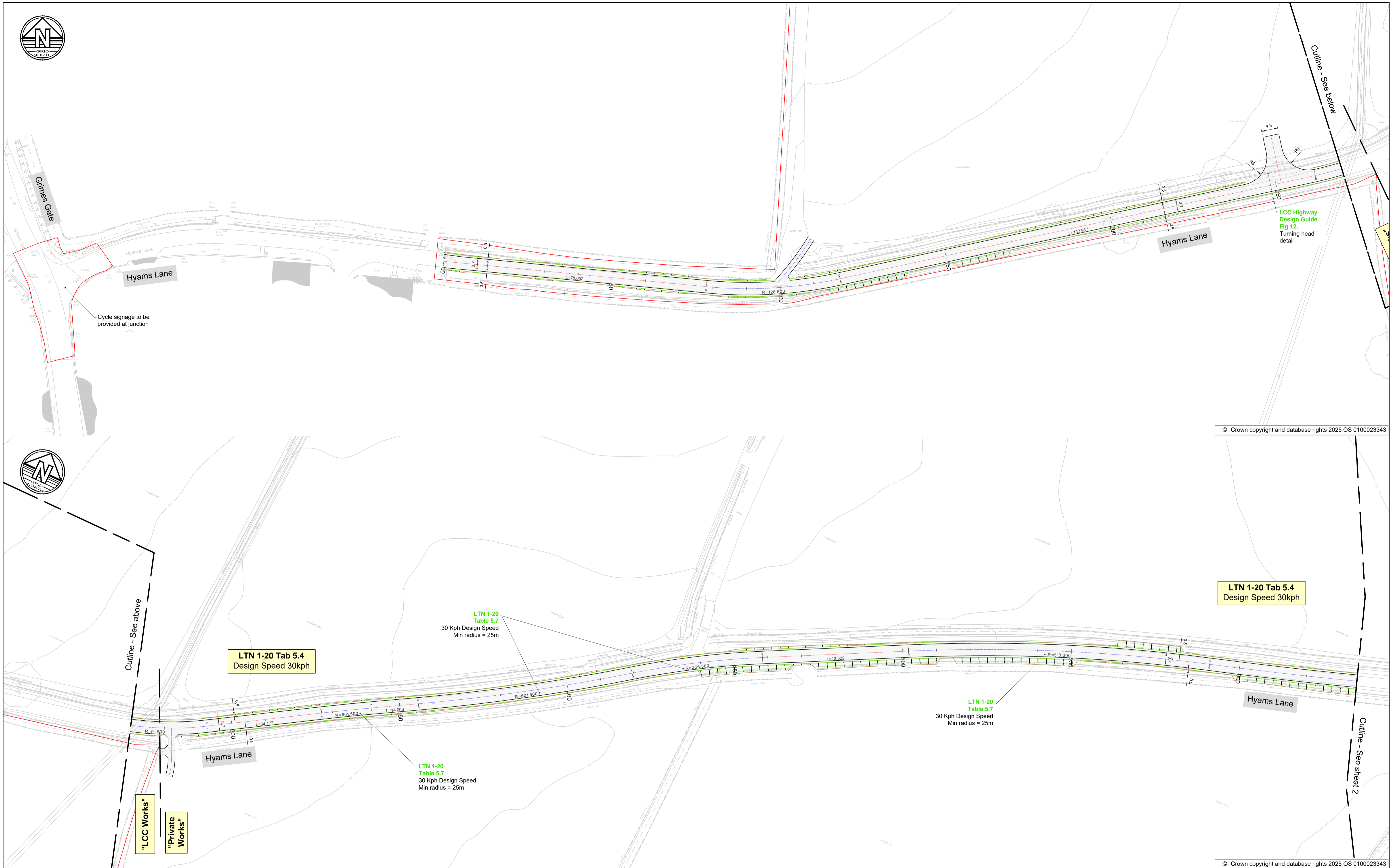

© Crown copyright and database rights 2025 OS 0100023343

LTN 1-20 Tab 5.4
Design Speed 30kph

LTN 1-20 Tab 5.4
Design Speed 30kph

LTN 1-20
Table 5.7
30 Kph Design Speed
Min radius = 25m

LTN 1-20
Table 5.7
30 Kph Design Speed
Min radius = 25m

LTN 1-20
Table 5.7
30 Kph Design Speed
Min radius = 25m

© Crown copyright and database rights 2025 OS 0100023343

Notes

- Do not scale this drawing. All dimensions must be checked/verified on site. If in doubt ask.
- This drawing is to be read in conjunction with all relevant architects, engineers and specialists drawings and specifications.
- All dimensions in metres unless noted otherwise. All levels in metres unless noted otherwise.
- Any discrepancies noted on site are to be reported to the engineer immediately.
- Annotation shown coloured green achieves design standards
- Annotation shown coloured amber is a relaxation from design standards
- Annotation shown coloured red is a departure from design standards

Legend

- Draft Order Limits
- Alignment - Straights
- Alignment - Curves
- Alignment - Transitions
- Carriageway area
- Taper for cross section width change

ISSUES & REVISIONS

Rev	Date	Details of issue / revision	Drw	Rev
P01	14.05.25	Issue for information	MS	SH

BWB
A CAF GROUP COMPANY

- Birmingham | 0121 233 3322
- Leeds | 0113 233 8000
- London | 020 7234 9122
- Manchester | 0161 233 4260
- Nottingham | 0115 924 1100
- www.bwbconsulting.com

Client

SEGRO

Drawn: M.S. | Reviewed: S.H.
BIWB Ref: 220500 | Date: 14.05.25 | Scale@A1: 1:500

Project Title

East Midlands Gateway 2

Drawing Status

FOR INFORMATION

Drawing Title

**Hyam Lane
Geometry Plans
Sheet 1 of 2**

Project - Originator - Zone - Level - Type - Role - Number

EMG2-BWB-HGN-HYAM-DR-H-0101

Status

S2

Rev

P01

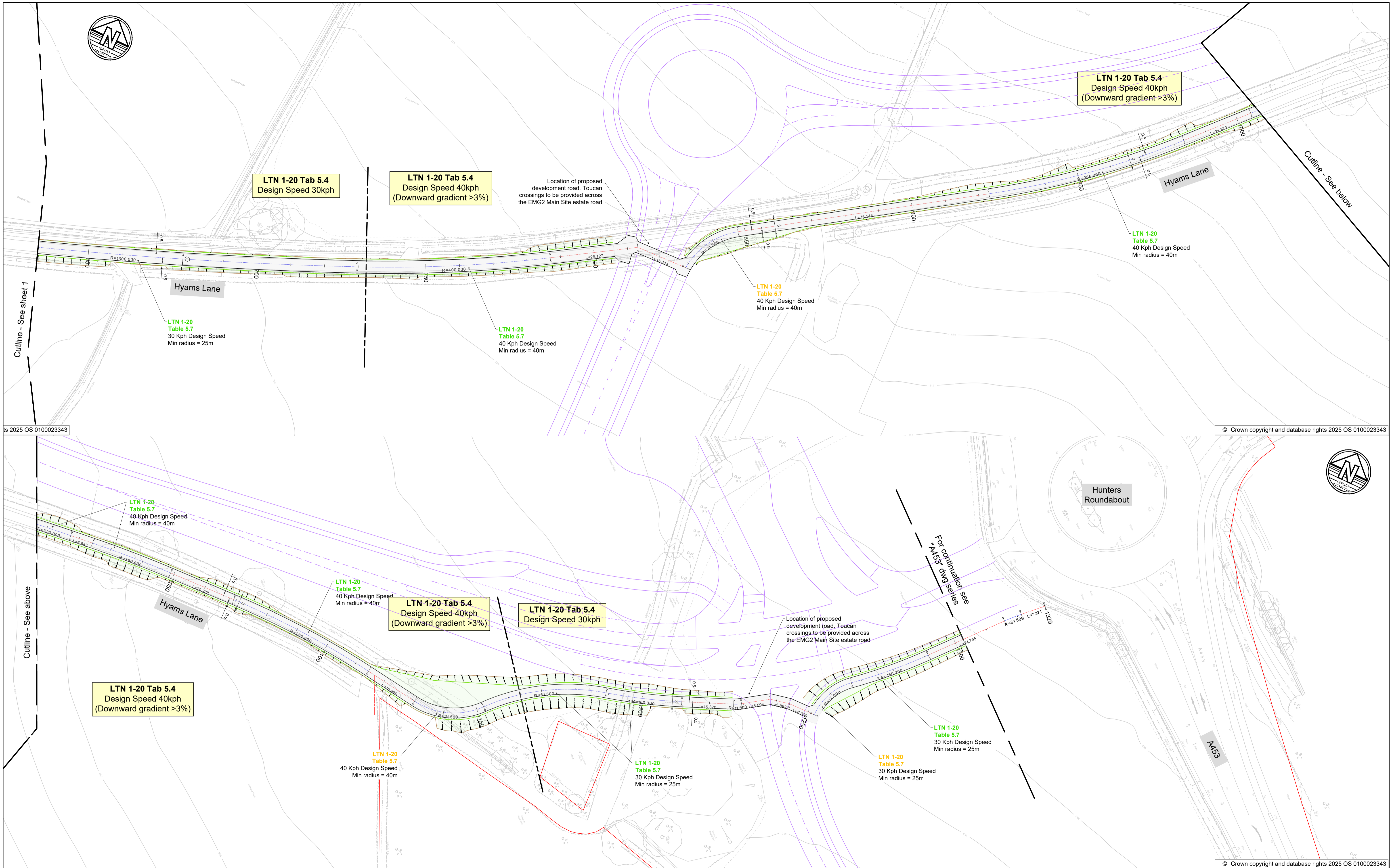

Notes

- Do not scale this drawing. All dimensions must be checked/verified on site. If in doubt ask.
- This drawing is to be read in conjunction with all relevant architects, engineers and specialists drawings and specifications.
- All dimensions in metres unless noted otherwise. All levels in metres unless noted otherwise.
- Any discrepancies noted on site are to be reported to the engineer immediately.
- Annotation shown coloured green achieves design standards
- Annotation shown coloured amber is a relaxation from design standards
- Annotation shown coloured red is a departure from design standards

Legend

- Draft Order Limits
- Alignment - Straights
- Alignment - Curves
- Alignment - Transitions
- Carriageway area
- Taper for cross section width change
- Main site estate road (illustrative)

ISSUES & REVISIONS

Rev	Date	Details of issue / revision	Drw	Rev
P01	14.05.25	Issue for information	MS	SRH
P02	11.07.25	Main site estate road added	MS	SRH

BWB
A CAF GROUP COMPANY

Birmingham | 0121 233 3322
 Leeds | 0113 233 8000
 London | 020 7234 9122
 Manchester | 0161 233 4260
 Nottingham | 0115 924 1100
www.bwbconsulting.com

Client

SEGRO

Drawn: M.S. | Reviewed: S.H. | Date: 14.05.25 | Scale@A1: 1:500

Project Title

East Midlands Gateway 2

Drawing Status

FOR INFORMATION

Drawing Title

**Hyam Lane
Geometry Plans
Sheet 2 of 2**

Project - Originator - Zone - Level - Type - Role - Number

EMG2-BWB-HGN-HYAM-DR-H-0102

Status Rev

S2 P02

ts 2025 OS 0100023343

© Crown copyright and database rights 2025 OS 0100023343

© Crown copyright and database rights 2025 OS 0100023343

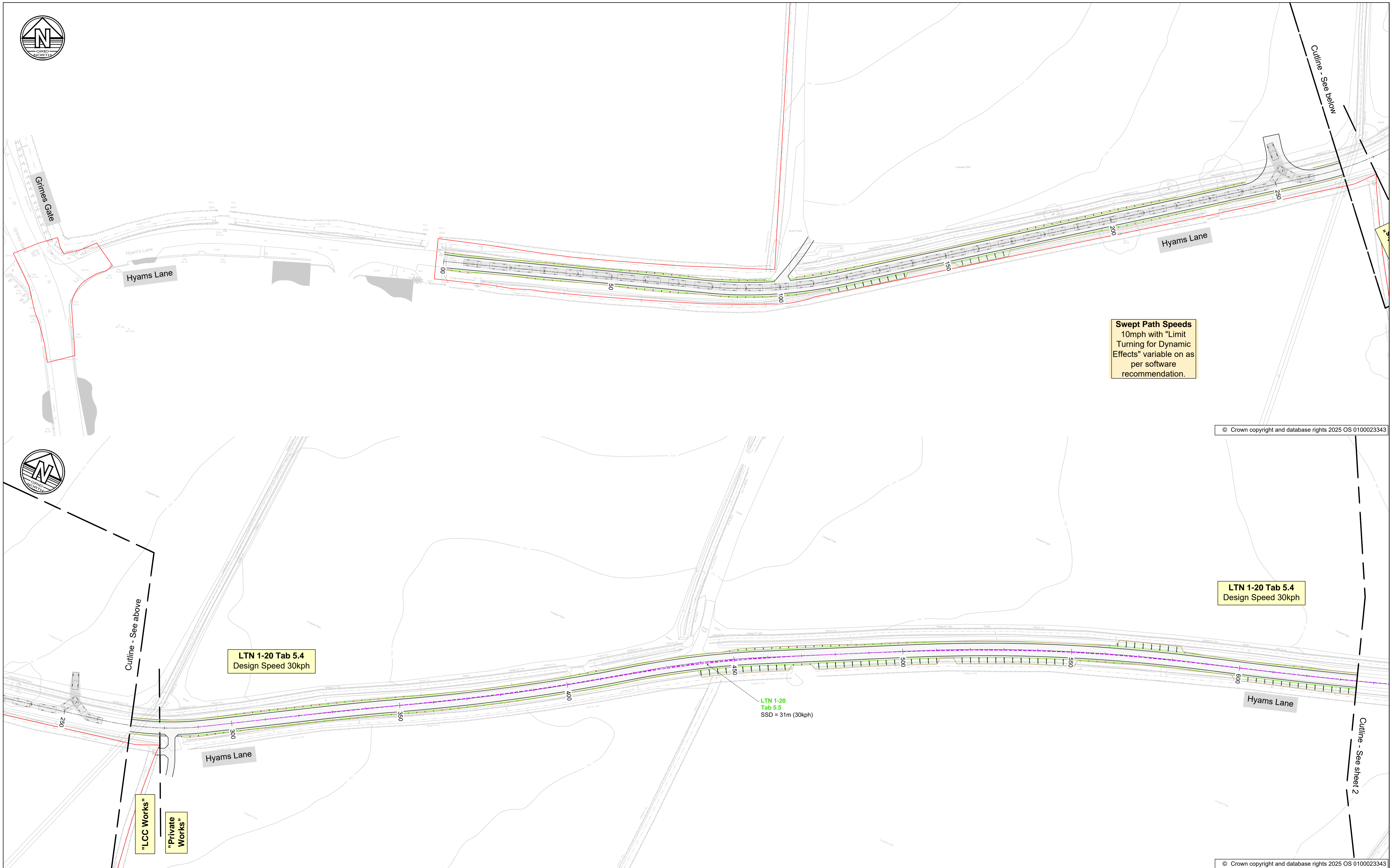

© Crown copyright and database rights 2025 OS 0100023343

LTN 1-20 Tab 5.4
Design Speed 30kph

LTN 1-20 Tab 5.4
Design Speed 30kph

LTN 1-20
Tab 5.5
SSD = 31m (30kph)

© Crown copyright and database rights 2025 OS 0100023343

Notes

- Do not scale this drawing. All dimensions must be checked/ verified on site. If in doubt ask.
- This drawing is to be read in conjunction with all relevant architects, engineers and specialists drawings and specifications.
- All dimensions in metres unless noted otherwise. All levels in metres unless noted otherwise.
- Any discrepancies noted on site are to be reported to the engineer immediately.
- Visibility sight lines shown are in plan view only. These are to be checked vertically against the design / existing surfaces at detailed design stage.

© Copyright BWB Consulting Ltd

Legend

	LCC Works
	Private Works
	LTN 1-20 Tab 5.4
	LTN 1-20 Tab 5.5

ISSUES & REVISIONS

Rev	Date	Details of issue / revision	Drw	Rev
P01	14.05.25	Issue for information	MS	SH

BWB
A CAF GROUP COMPANY

Birmingham | 0121 233 3322
 Leeds | 0113 233 8000
 London | 020 7234 9122
 Manchester | 0161 233 4260
 Nottingham | 0115 924 1100
www.bwbconsulting.com

Client

SEGRO

Drawn: M.S | Reviewed: S.H
 BWB Ref: 220500 | Date: 14.05.25 | Scale@A1: 1:500

Project Title

East Midlands Gateway 2

Drawing Status

FOR INFORMATION

Drawing Title

**Hyam Lane
Vehicle Swept Paths &
Visibility
Sheet 1 of 2**

Project - Originator - Zone - Level - Type - Role - Number | Status | Rev

EMG2-BWB-HGN-HYAM-DR-H-0110 | S2 | P01

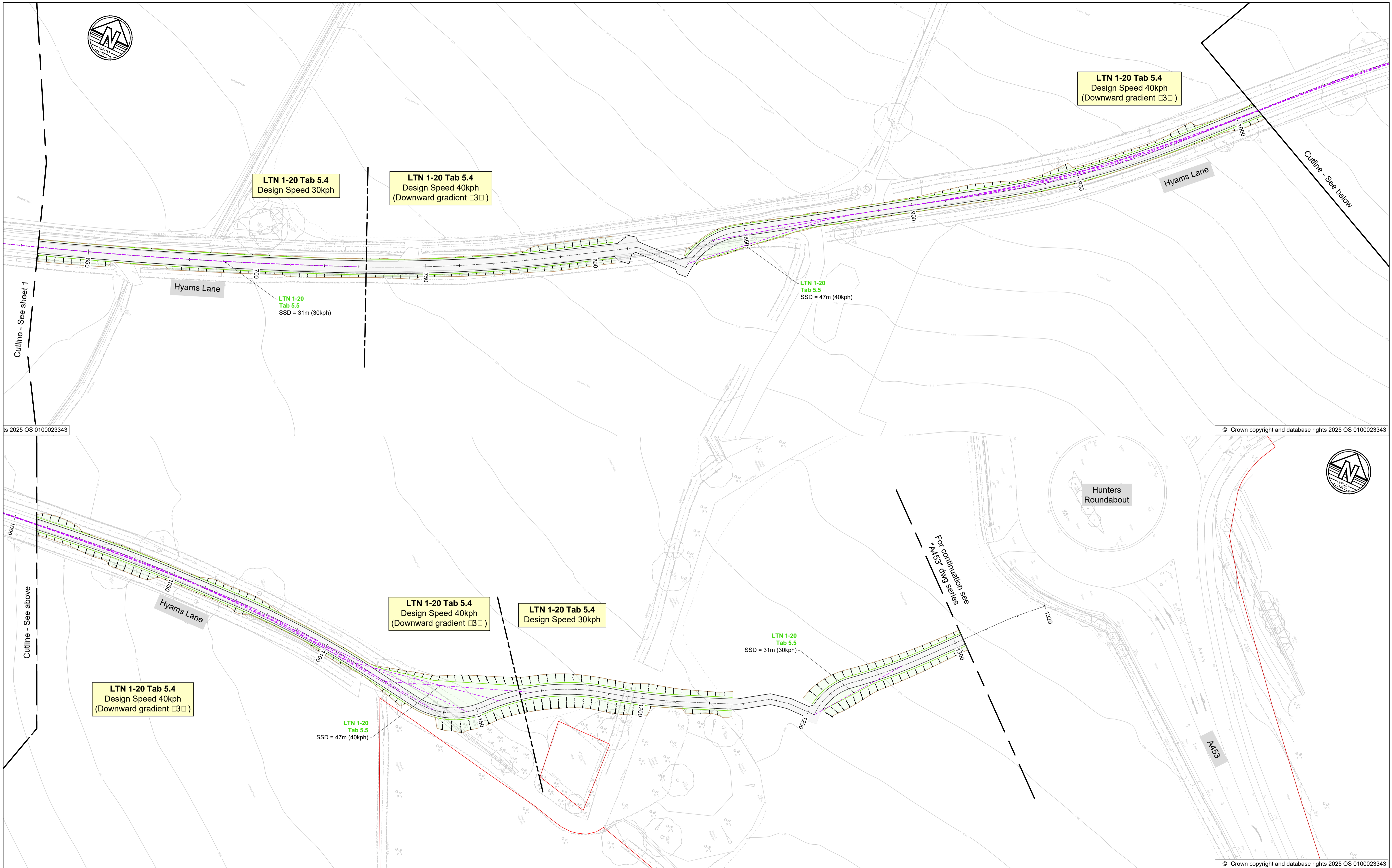

ts 2025 OS 0100023343

© Crown copyright and database rights 2025 OS 0100023343

© Crown copyright and database rights 2025 OS 0100023343

Notes

- Do not scale this drawing. All dimensions must be checked/ verified on site. If in doubt ask.
- This drawing is to be read in conjunction with all relevant architects, engineers and specialists drawings and specifications.
- All dimensions in metres unless noted otherwise. All levels in metres unless noted otherwise.
- Any discrepancies noted on site are to be reported to the engineer immediately.
- Visibility sight lines shown are in plan view only. These are to be checked vertically against the design / existing surfaces at detailed design stage.

© Copyright BWB Consulting Ltd

Legend

	LTN 1-20 Tab 5.4
	LTN 1-20 Tab 5.5
	Design Speed 30kph
	Design Speed 40kph

ISSUES & REVISIONS

Rev	Date	Details of issue / revision	Drw	Rev
P01	14.05.25	Issue for information	MS	SH

BWB
A CAF GROUP COMPANY

Birmingham | 0121 233 3322
 Leeds | 0113 233 8000
 London | 020 7234 9122
 Manchester | 0161 233 4260
 Nottingham | 0115 924 1100
www.bwbconsulting.com

Client

SEGRO

Drawn: M.S | Reviewed: S.H
 BWB Ref: 220500 | Date: 14.05.25 | Scale@A1: 1:500

Project Title

East Midlands Gateway 2

Drawing Status

FOR INFORMATION

Drawing Title

Hyam Lane Vehicle Swept Paths & Visibility
Sheet 2 of 2

Project - Originator - Zone - Level - Type - Role - Number | Status | Rev

EMG2-BWB-HGN-HYAM-DR-H-0111 | S2 | P01

**APPENDIX 27: Geometric Design Strategy Record for the Strategic Road Network
(document reference EMG2-BWB-GEN-XX-RP-CH-0013_S3-P04)**

INFRASTRUCTURE

SEGRO
East Midlands Gateway 2
Leicestershire
Geometric Design Strategy Record
(National Highways Network)

~~**INFRASTRUCTURE**~~ ~~**INFRASTRUCTURE**~~

~~SEGRO~~ ~~SEGRO~~

~~East Midlands Gateway 2~~ ~~East Midlands Gateway 2~~

~~Leicestershire~~

~~Geometric Design Strategy Record~~

~~(National Highways Network) Geometric Design Strategy Record~~

~~(National Highways Network)~~

Nottingham
5th Floor, Waterfront House, Station Street
Nottingham, NG2 3DQ
T: 0115 924 1100

~~August 2025~~

March 2026

DOCUMENT ISSUE RECORD

Document Number:	EMG2-BWB-GEN-XX-RP-CH-0013
BWB Reference:	220500

Revision	Date of Issue	Status	
<u>1P01</u>	04.03.2025	For comment	
<u>2P02</u>	10.03.2025	For comment	
<u>3P03</u>	27.06.2025	For comment	
<u>4P04</u>	26.08.2025	For DCO submission	
<u>P05</u>	<u>18.03.2026</u>	<u>Design update</u>	

<u>P06</u>	<u>31.03.2026</u>	<u>Appendix 4 update</u>
------------	-------------------	------------------------------

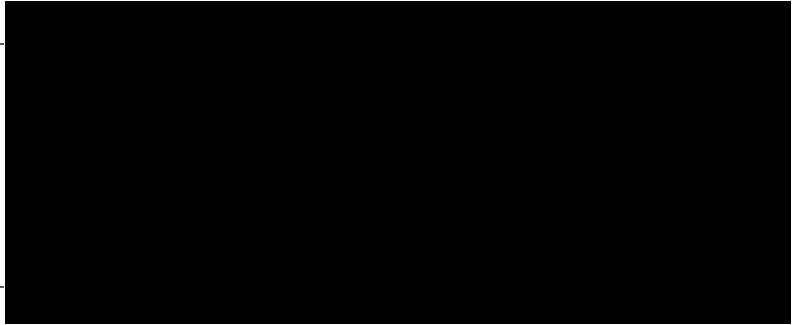

Notice

This document has been prepared for the sole use of the Client in accordance with the terms of the appointment under which it was produced. BWB Consulting Limited accepts no responsibility for any use of or reliance on the contents of this document by any third party. No part of this document shall be copied or reproduced in any form without the prior written permission of BWB.

CONTENTS

1. INTRODUCTION.....	1
Instruction	1
Acronyms and Abbreviations	2
Objectives	2
Traffic data	3
List of Drawings.....	3
2. SCHEME OVERVIEW AND DESIGN STANDARDS	5
Scheme overview.....	5
Overview of Standards	5
Safety Risk Assessment	6
Highway Authority, Road Class, Design Speed and Speed Limit	6
3. M1 JCT 24 NORTHBOUND DIVERGE	8
Layout	8
Design Speed and Geometry.....	10
Stopping Sight Distance / Visibility.....	11
Cross Section (Connector Road – Slip Road).....	11
4. M1 JCT 24A NORTHBOUND DIVERGE TO A50	13
Diverge Layout.....	13
Weaving and spacing of successive diverges	16
Visibility (SSD) into the J24A diverge	19
M1 mainline cross-section.....	19
Provision of directional signs and signalling	20
Visibility of the J24 diverge	22
Gradient of the M1 on the approach to the two diverges.....	22
Length of the downstream interchange link to the A50.....	23
Summary and preferred option	24
Further measures to maximise weaving length	25
Departures From Standard	27
5. M1 NORTHBOUND TO A50 WESTBOUND INTERCHANGE LINK	28
Layout	28
Traffic flows.....	28
Design Speed and Geometry.....	28
Stopping Sight Distance / Visibility.....	30
Cross-section (Connector Road – Interchange Link).....	31
Safety risk assessment, summary and preferred option.....	32

Departures From Standard	33
6. A50 WESTBOUND MERGE	34
Layout	34
Design Speed and Geometry	36
Stopping Sight Distance / Visibility	37
Speed limit	38
Departures From Standard	38
7. M1 SOUTHBOUND / A50 EASTBOUND TO M1 JCT 24 INTERCHANGE LINKS	39
Layout	39
Traffic Flows	39
Design Speed and Geometry	40
Stopping Sight Distance / Visibility	41
Weaving	41
Cross Section	42
8. A453 SHARED USE CYCLE/FOOTWAY	43
Layout	43
Traffic Flows	43
Design Speed and Geometry	43
Visibility	44
Departures From Standard	44
9. A453 / A6 / EMG1 ACCESS JUNCTION	45
Layout	45
Traffic Flows	45
Design Speed and Geometry	45
Visibility	46
10. OTHER WORKS ON THE SRN	47
M1 J24 signalised roundabout traffic signing and road marking alterations	47
M1 J24 signalised roundabout west side	47
Finger Farm directional signage	47
M1 northbound directional signage	47
11. PRINCIPLES OF GOOD ROAD DESIGN	48
1. INTRODUCTION	1
Instruction	1
Acronyms and Abbreviations	2
Objectives	2
Summary of changes from August 2025	3
Traffic data	3

	List of Drawings.....	4
2.	SCHEME OVERVIEW AND DESIGN STANDARDS	6
	Scheme overview.....	6
	Overview of Standards	6
	Safety Risk Assessment	7
	Highway Authority, Road Class, Design Speed and Speed Limit	7
3.	M1 JCT 24 NORTHBOUND DIVERGE	9
	Layout	9
	Design Speed and Geometry	12
	Stopping Sight Distance / Visibility	13
	Cross Section (Connector Road – Slip Road).....	13
4.	M1 JCT 24A NORTHBOUND DIVERGE TO A50	15
	Diverge Layout.....	15
	Weaving and spacing of successive diverges	19
	Visibility (SSD) into the J24A diverge	24
	M1 mainline cross-section.....	24
	Provision of directional signs and signalling	25
	Visibility of the J24 diverge	28
	Gradient of the M1 on the approach to the two diverges.....	28
	Length of the downstream interchange link to the A50.....	28
	Summary and preferred option	29
	Further measures to maximise weaving length	31
	Departures From Standard	32
5.	M1 NORTHBOUND TO A50 WESTBOUND INTERCHANGE LINK	33
	Layout	33
	Traffic flows	33
	Design Speed and Geometry	33
	Stopping Sight Distance / Visibility	35
	Cross-section (Connector Road – Interchange Link)	36
	Safety risk assessment, summary and preferred option.....	38
	Departures From Standard	39
6.	A50 WESTBOUND MERGE	40
	Layout	40
	Design Speed and Geometry	43
	Stopping Sight Distance / Visibility	45
	Speed limit	45
	Departures From Standard	45

7.	M1 SOUTHBOUND / A50 EASTBOUND TO M1 JCT 24 INTERCHANGE LINKS	46
	Layout	46
	Traffic Flows	46
	Design Speed and Geometry	47
	Stopping Sight Distance / Visibility	48
	Weaving.....	48
	Cross Section	49
8.	A453 SHARED USE CYCLE/FOOTWAY	50
	Layout	50
	Traffic Flows	50
	Design Speed and Geometry	50
	Visibility	51
9.	A453 / A6 / EMG1 ACCESS JUNCTION	52
	Layout	52
	Traffic Flows	52
	Design Speed and Geometry	52
	Visibility	53
10.	OTHER WORKS ON THE SRN.....	54
	M1 J24 signalised roundabout traffic signing and road marking alterations.....	54
	M1 J24 signalised roundabout west side	54
	Finger Farm directional signage	54
	M1 northbound directional signage	55
11.	PRINCIPLES OF GOOD ROAD DESIGN	56

FIGURES

Figure 1.1 Location plan

Figure 3.1 M1 J24 northbound diverge layout requirement using traffic data

Figure 4.1 M1 J24A northbound diverge layout requirement using traffic data

Figure 5.1 High load routes and location of proposed bridge

Figure 6.1 A50 westbound merge layout requirement using traffic data

APPENDICES

~~APPENDIX 1: Safety Risk Assessment for M1 NB diverge and weaving length~~

~~APPENDIX 2: Safety Risk Assessment for M1 NB to A50 WB interchange link~~

~~APPENDIX 3: List of Road Layout departures from standard for proposed scheme~~

~~APPENDIX 1: Safety Risk Assessment for M1 NB diverge and weaving length~~

~~APPENDIX 2: Safety Risk Assessment for M1 J23A-24 northbound number of lanes in the weaving length and the J24A northbound diverge type~~

[APPENDIX 3: Safety Risk Assessment for M1 NB to A50 WB interchange link](#)
[APPENDIX 4: List of Road Layout departures from standard for proposed scheme](#)

1. INTRODUCTION

Instruction

- 1.1 The EMG2 development, which although located south of East Midlands Airport (EMA), proposes substantial improvements to the strategic road network (SRN) at M1 junction 24 along with works to the A453 south of J24.
- 1.2 BWB Consulting (BWB) has been instructed by SEGRO (the Client) to develop the highway design for the works on the SRN which includes the preparation of this Design Strategy Record (DSR).
- 1.3 **Figure 1.1** below shows the overall location of the works in the context of EMG2 and the existing road network.

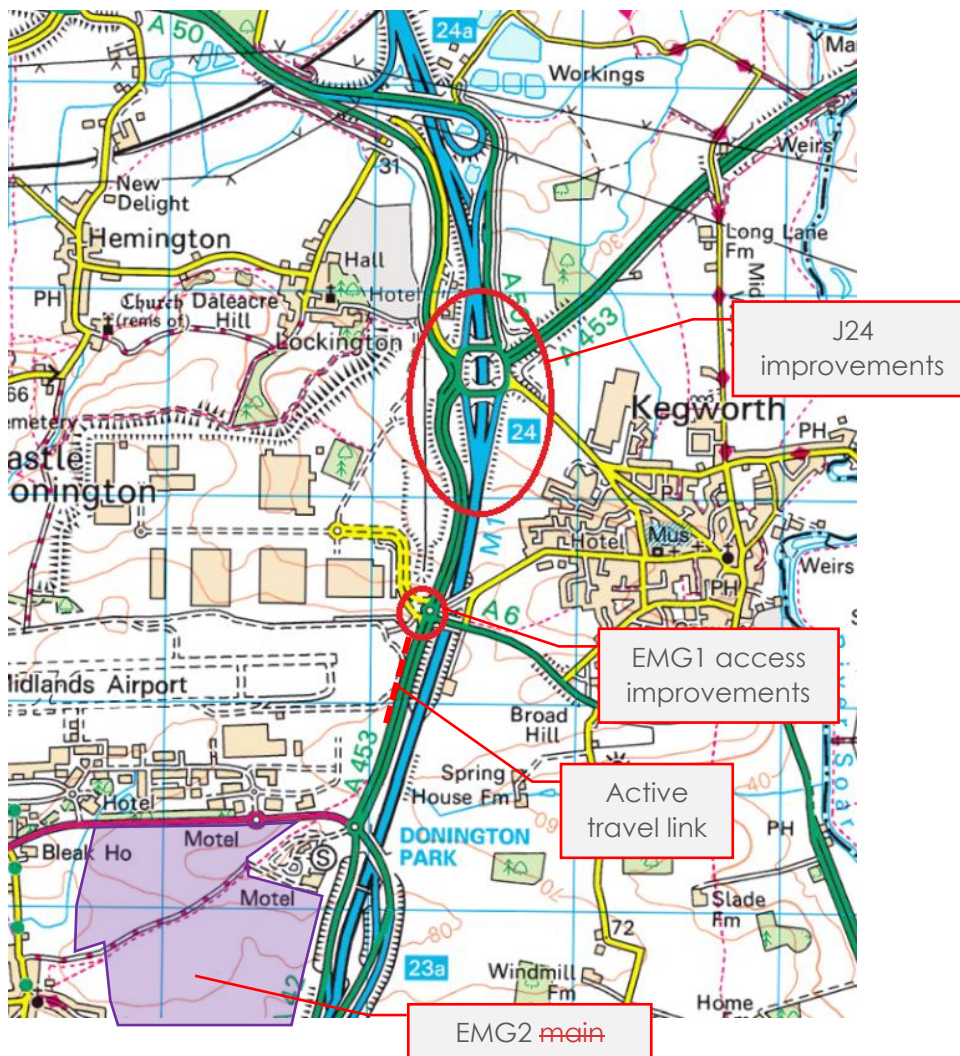

Figure 1.1 Location plan

- 1.4 This report contains consideration of several options relating to specific elements of the scheme (namely the M1 northbound diverge and A453 bridge). These have been discussed with National Highways and feedback received, which has then been incorporated into the design proposals. Formal submissions for departures from standard ~~will be~~ have been made separately to this report

Acronyms and Abbreviations

ALR	All-lane running
ALS	Above-lane signals
DMRB	Design Manual for Roads and Bridges
DfT	Department for Transport
DSR	Design Strategy Record
EMA	East Midlands Airport
EMG1	East Midlands Gateway 1
EMG2	East Midlands Gateway 2
LCC	Leicestershire County Council
NH	National Highways
SLTL	Segregated left-turn lane
SMP	Smart Motorway Project
SRN	Strategic Road Network
VMSL	Variable mandatory speed limits
VMS	Variable message sign
VRS	Vehicle Restraint System

Objectives

- 1.5 The objective of this DSR report, is to record the key decisions made during the layout design.
- 1.6 The report ~~will record~~ records the relaxations and departures from standards contained within the highway design. A detailed narrative for the justification, including a safety risk assessment, ~~is to be submitted~~ has been separately for approval for each departure.
- 1.7 The DSR is also used to record how the scheme complies with the principles of good road design set out in GG 103.
- 1.8 The following reports and documents are to be provided separately to this DSR:
- Transport assessment and modelling;
 - Geotechnical reporting to CD 622;
 - Directional signage strategy;
 - Lighting strategy;
 - Structures options reports and AIPs to CG 300;
 - Maintenance and repair statement to GD 304;
 - WCHAR assessment and review to GG 142; and
 - Stage 1 road safety audit to GG 119.

Traffic data

~~Traffic data has been obtained~~ Summary of changes from the LCC 2019 pan regional transport model (PRTM 2019). August 2025

- 1.9 ~~The modelling is detailed within the EMG2 project August version (revision P04) of this report was issued as an Appendix to the Transport Assessment, for EMG2. Since this time the geometric design has been progressed based on finalised traffic data and a summary of the principal changes made to this report is as follows:~~

- ~~For the purposes of the highway design two sets of Traffic data used throughout the report has been updated and any geometrical requirements based on traffic data have been provided~~ reassessed
- 1.10 • ~~Departure G6 has been merged into G7 as follows: a single departure~~
- ~~Model '2A'~~ Departure G11 is no longer required
- ~~Departures G13 and G14 have been identified (based on the updated traffic data) and added~~
- ~~Appendix 3 has been added~~
- ~~Appendix 4 (was 3) has been updated to provide the approval status of all of the departures from standard required for the selected scheme~~
- ~~Design changes identified as actions arising from the Stage 1 Road Safety Audit have been incorporated~~

Traffic data

- 1.10 ~~A detailed traffic modelling exercise has been undertaken for EMG2. The outputs from this modelling have been reviewed by the National Highways Spatial Planning Team and their transport consultant. Based on this process, the predicted flows (extracted from the VISSIM modelling) or demand flows as appropriate, for the 2038 design year, are agreed as being robust for the purposes of the scheme design and departure submissions. The traffic data used in this report is derived from the 2019 PRTM.~~

- 1.11 ~~However, an assessment of the scheme using the 2023 PRTM has been undertaken which includes draft local plan allocations but confirmed that the use of the 2023 model does not include associated affect the proposed design of the highway mitigation in all cases; and works. This is documented in the PRTM 2023 Modelling Sensitivity Test Technical Note.~~

- ~~Model '2B' for 2038 which excludes draft local plan allocations.~~

- 1.11 ~~Both of the above are reviewed in this report.~~

- 1.12 ~~The difference between forecast and demand flows arises on the flow for the M1 northbound to A50 westbound interchange link in the PM peak hour which is due to a slight delay at the J23A northbound merge due to traffic joining from the A42. For the purposes of this assessment the forecast flows are used for the M1 mainline and the demand flows are used for the M1 northbound to A50 westbound interchange link. The forecast flows are representative for the four-lane M1 mainline from J23A to J24. However, if further capacity was released by a future scheme (e.g. widening this section~~

of the M1 to five lanes) then more traffic is predicted to use the interchange link and hence for robustness it is appropriate to use the demand flows in assessing the interchange link.

List of Drawings

4.121.13 The table below sets out the scheme design and option drawings that are to be read in conjunction with this report. They are provided at the end of this report.

Drawing no.	Title	Report section
EMG2-BWB-GEN-XX-SK-CH-SK037	Overview of works on the strategic road network	All
EMG2-BWB-GEN-XX-SK-CH-SK032	M1 Northbound diverge options Sheet 1	3 & 4
EMG2-BWB-GEN-XX-SK-CH-SK033	M1 Northbound diverge options Sheet 2	3 & 4
EMG2-BWB-GEN-XX-SK-CH-SK034	M1 J24 and J24A NB Diverge Layout Option A	3 & 4
EMG2-BWB-GEN-XX-SK-CH-SK035	M1 J24 and J24A NB Diverge Layout Option C	3 & 4
EMG2-BWB-GEN-XX-SK-CH-SK036	M1 J24 and J24A NB Diverge Layout Option D	3 & 4
<u>EMG2-BWB-GEN-XX-SK-CH-SK065</u>	<u>M1 Northbound diverge options Sheet 3</u>	<u>3 & 4</u>
EMG2-BWB-HGN-M1NBS-DR-H-0101	M1 Northbound Slip Road Geometry Plans Sheet 1 of 4	4 & 5
EMG2-BWB-HGN-M1NBS-DR-H-0102	M1 Northbound Slip Road Geometry Plans Sheet 2 of 4	4 & 5
EMG2-BWB-HGN-M1NBS-DR-H-0103	M1 Northbound Slip Road Geometry Plans Sheet 3 of 4	4 & 5
EMG2-BWB-HGN-M1NBS-DR-H-0104	M1 Northbound Slip Road Geometry Plans Sheet 4 of 4	4 & 5
EMG2-BWB-HGN-M1NBS-DR-H-0110	M1 Northbound Offslip Vehicle Swept Paths & Visibility Sheet 1 of 4	4 & 5
EMG2-BWB-HGN-M1NBS-DR-H-0111	M1 Northbound Offslip Vehicle Swept Paths & Visibility Sheet 2 of 4	4 & 5
EMG2-BWB-HGN-M1NBS-DR-H-0112	M1 Northbound Offslip Vehicle Swept Paths & Visibility Sheet 3 of 4	4 & 5
EMG2-BWB-HGN-M1NBS-DR-H-0113	M1 Northbound Offslip Vehicle Swept Paths & Visibility Sheet 4 of 4	4 & 5
EMG2-BWB-GEN-XX-SK-CH-SK030	M1 Northbound to A50 Westbound Interchange Link Option 1	5
EMG2-BWB-GEN-XX-SK-CH-SK018	M1 Northbound to A50 Westbound Interchange Link Option 2A K17	5
EMG2-BWB-GEN-XX-SK-CH-SK031	M1 Northbound to A50 Westbound Interchange Link Option 2B K30	5
EMG2-BWB-HGN-A50WB-DR-H-0101	A50 Westbound Geometry Plans Sheet 1 of 2	6
EMG2-BWB-HGN-A50WB-DR-H-0102	A50 Westbound Geometry Plans Sheet 2 of 2	6
EMG2-BWB-GEN-XX-SK-CH-SK046	A50 westbound link schematic	6
EMG2-BWB-HGN-A50EB-DR-H-0101	A50 Eastbound Geometry Plans Sheet 1 of 2	7
EMG2-BWB-HGN-A50EB-DR-H-0102	A50 Eastbound Geometry Plans Sheet 2 of 2	7
EMG2-BWB-HGN-A453-DR-H-0103	A453 Geometry Plans Sheet 3 of 4	8
EMG2-BWB-HGN-A453-DR-H-0104	A453 Geometry Plans Sheet 4 of 4	8
EMG2-BWB-HGN-EMG1-DR-H-0101	<u>Existing-A6-A453-EMG1 Junction Geometry Plan</u>	9
EMG2-BWB-GEN-XX-SK-CH-SK038 HGN-EMG1-DR-H-0102	<u>Existing-A6-A453-EMG1 Junction Vehicle TrackingSwept Paths</u>	9

4.131.14 Based on the findings of this report, the highway design for the highway works on the SRN is shown on the following formal DCO Documents. These are not appended to this report.

Drawing no.	Title	DCO document no.
EMG2-BWB-HGN-XX-DR-H-0100	Highways Plans General Arrangement Key Plan	DCO 2.8
EMG2-BWB-HGN-XX-DR-H-0101	Highways Plans General Arrangement Sheet 1	DCO 2.8A
EMG2-BWB-HGN-XX-DR-H-0102	Highways Plans General Arrangement Sheet 2	DCO 2.8B
EMG2-BWB-HGN-XX-DR-H-0103	Highways Plans General Arrangement Sheet 3	DCO 2.8C
EMG2-BWB-HGN-XX-DR-H-0104	Highways Plans General Arrangement Sheet 4	DCO 2.8D
EMG2-BWB-HGN-XX-DR-H-0132	Highway Plans Cross Sections Sheet 2 of 3	DCO 2.9B
EMG2-BWB-HGN-XX-DR-H-0133	Highway Plans Cross Sections Sheet 3 of 3	DCO 2.9C
EMG2-BWB-HGT-M1NBS-DR-H-0651	EMG2 M1 Northbound to A50 Westbound Interchange Link Geometry Profiles	DCO 2.10A
EMG2-BWB-HGT-A50EB-DR-H-0651	EMG2 A50 Eastbound Geometry Profiles	DCO 2.10B
EMG2-BWB-HGT-A453-DR-H-0651	EMG2 A453 Geometry Profiles-S2-P02	DCO 2.10C
EMG2-CH-SBR-BR-DR-CB-00024	A453 Bridge Plan	DCO 2.11

2. SCHEME OVERVIEW AND DESIGN STANDARDS

Scheme overview

2.1 The proposed works on the SRN are listed below, collectively referred to within this report as the SRN works.

- J24 Improvements comprising:
 - M1 northbound to A50 westbound link – providing a new free-flow link road from the M1 northbound at J24 to provide a direct link to the A50 westbound, which will cross over the A453, and will include the A50 westbound merge alterations;
 - M1 southbound and A50 eastbound link to J24 widening – providing widening of the A50 eastbound link at J24 and other related works and traffic management measures in this location;
 - Works to the west side of the M1 Junction 24 roundabout and A453 northbound approach;
 - Works to the east side of the M1 Junction 24 roundabout and A453 southbound approach; and
 - M1 northbound alterations – providing the new M1 northbound exit and associated gantry/signage improvements on the M1.
- EMG1 Access Improvements and pedestrian crossing comprising:
 - widening at the EMG1 signalised junction to increase capacity; and
 - A controlled pedestrian crossing and footway link between the proposed EMG1 Wilders Way drop-off lay-by and EMG1 Bus Interchange.
- Active Travel works (so far as they fall within the SRN) comprising an Active Travel Link – providing a dedicated shared unsegregated cycle/footway adjacent to the A453 between EMG1 and the EMG2 Main Site; and
- Directional signage works at the Finger Farm roundabout and on the M1 Northbound approach to J23A (this is not covered by this report but will be provided in the directional signage strategy).

2.2 **Drawing EMG2-BWB-GEN-XX-SK-CH-SK037** shows the locations of the above works and **Figure 1.1** above shows the overall location of the SRN works in the context of EMG2 and the existing road network.

Overview of Standards

2.3 The scheme spans across two highway authority boundaries, NH and LCC. This report provides design commentary on the NH areas of responsibility only i.e. the SRN works. The LCC design commentary is covered by a separate report.

2.4 The SRN works will be designed in accordance with the following DMRB standards:

Doc. Ref.	Document Title	Version / Revision
CD 109	Highway link design	Revision 1
CD 116	Geometric design of roundabouts	Version 2.1.0
CD 122	Geometric design of grade separated junctions	Version 1.1.1
CD 123	Geometric design of at-grade priority and signal-controlled junctions	Version 2.1.0
CD 127	Cross-sections and headrooms	Version 1.0.1
CD 143	Designing for walking, cycling and horse-riding	Version 2.0.1
CD 146	Positioning of signalling and advance direction signs	Version 2.0.0
CD 195	Designing for cycle traffic	Version 1.0. 1 <u>2</u>

Safety Risk Assessment

~~2.5~~ 2.5 A safety risk assessment to GG 104 ~~has~~ have been completed to inform the decision making process for the following items:

~~2.5~~ 2.5 M1 Northbound diverge and weaving section ~~and~~; the assessment can be found at **Appendix 1**;

- ~~A safety risk~~ M1 J23A-24 northbound number of lanes in the weaving length and the J24A northbound diverge type; the assessment ~~to GG 104 has been completed to inform the decision making process for the~~ can be found at **Appendix 2**; and

~~2.6~~ 2.6 M1 Northbound to A50 westbound interchange link; the assessment and can be found at **Appendix 23**.

~~2.7.2.6~~ 2.7.2.6 Other safety risk assessments to GG 104 ~~will be~~ have been provided in support of formal applications for departures from standard ~~which will be submitted in due course~~.

Highway Authority, Road Class, Design Speed and Speed Limit

~~2.8.2.7~~ 2.8.2.7 The road classes and design speeds for each section of the scheme are listed below. Design speeds have been determined in accordance with CD 109, table 2.5 and CD 122, table 5.4.

Section of scheme	Road class	Design speed (kph)	Existing or proposed signed speed limit (mph)
M1 northbound mainline J23A-J24	Motorway	120	Existing national with VMSL
M1 J24 northbound diverge slip road	Motorway	70	Existing national with VMSL
M1 northbound to A50 westbound interchange link	Motorway	85	Proposed national with VMSL followed by mandatory 50
M1 J24 to A50 westbound interchange link	All-purpose	85	50 followed by national (change in speed limit to be relocated to end of proposed merge)

Section of scheme	Road class	Design speed (kph)	Existing or proposed signed speed limit (mph)
A50 eastbound to M1 J24 interchange link	All-purpose	85	Existing 50
A50 eastbound & M1 southbound to M1 J24 interchange link	All-purpose	85	Existing 50

3. M1 JCT 24 NORTHBOUND DIVERGE

Layout

3.1 The proposal is to amend the existing M1 J24 diverge by introducing a separate interchange link between the M1 northbound and A50 westbound, and reuse the existing slip road connector between the M1 northbound and J24 roundabout. The spacing between the two diverges is considered in the review of the proposed new diverge to the A50 found at section 4 below.

3.2 The following table sets out the 2038 design year traffic data for the J24 northbound diverge ~~using the 2A model data:~~

Location	AM Peak		PM Peak	
	Vehicles	HGVs	Vehicles	HGVs
M1 upstream of J24 diverge	4972	712	6326	802
M1 downstream of J24 diverge	3636	525	5308	650
J24 diverge slip road	1336	187	1018	152

~~3.3 The following table sets out the 2038 design year traffic data for the diverge using the 2B model data:~~

Location	AM Peak		PM Peak	
	Vehicles	HGVs% <u>HGV</u>	Vehicles	HGVs% <u>HGV</u>
M1 upstream of J24 diverge	4956 <u>5096</u>	546	6396 <u>6224</u>	959
M1 downstream of J24 diverge	3658 <u>3863</u>	351 <u>15.2</u>	5327 <u>5351</u>	799 <u>11.7</u>
J24 diverge slip road	1298 <u>1233</u>	195	1069 <u>873</u>	160

~~3.4.3~~ Based on CD 122, para 3.9, an adjustment factor for the presence volume of HGVs is ~~not~~ required on ~~downhill gradients or diverge flows~~ the mainline in the AM peak hour.

3.4 Using the traffic data above, with the adjustment as required by CD 122 para 3.9, and in accordance with CD 122 para 3.26 and Figure 3.26b, the data has been plotted on

EMG2: M1 J24: M1 NB diverge to J24

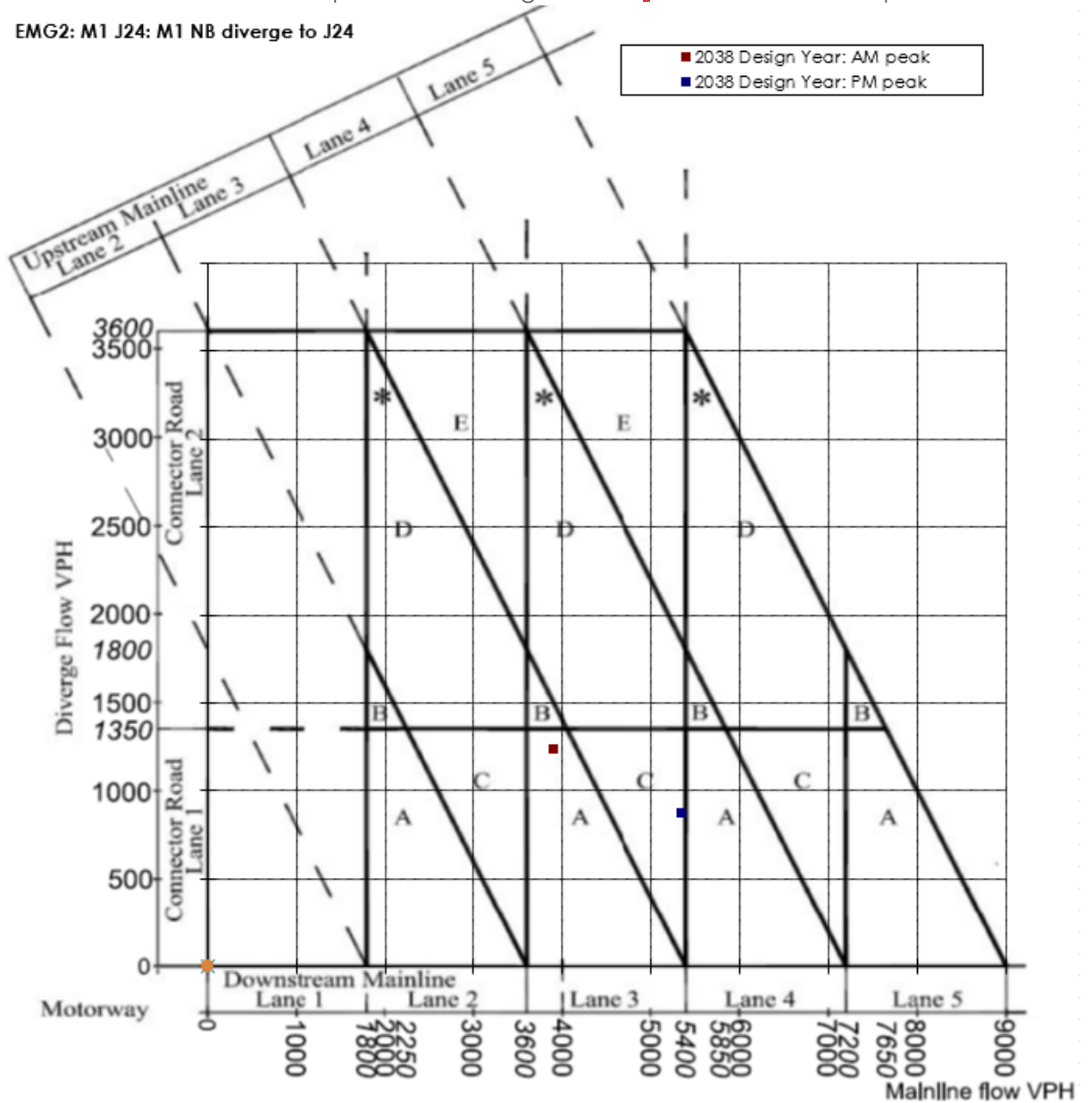

3.5—Figure

3.1

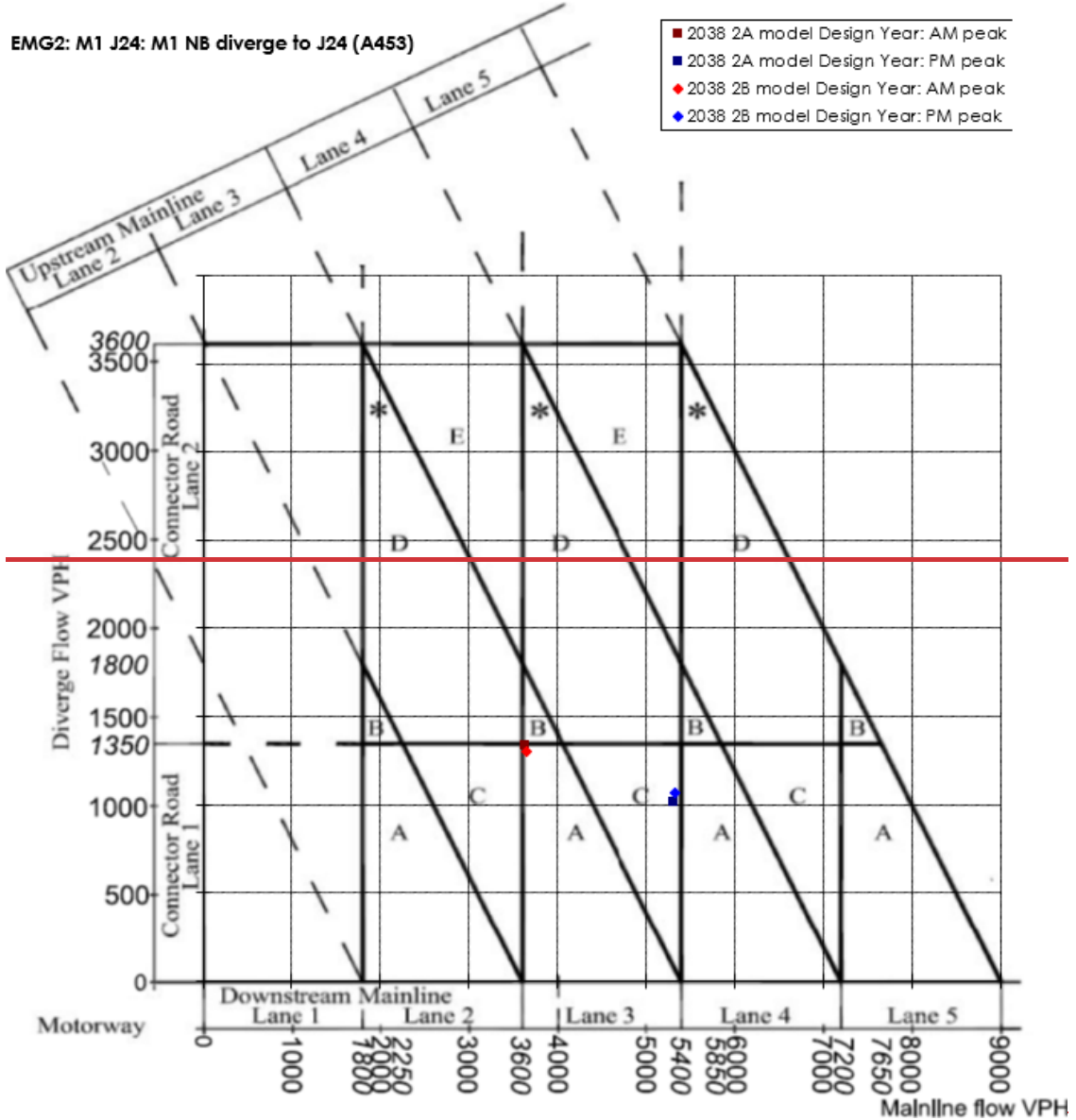

3.5 **Figure 3.1** below.

3.6 Based on this it is proposed to amend the diverge from the existing Layout B, option 1 'ghost island diverge' to a Layout A option 1, 'taper diverge' as shown in CD122 Figure 3.30a. Whilst in the PM peak a layout C diverge is suggested, if the main line flows increase then a layout A diverge would be required and therefore the layout A diverge has sufficient capacity.

EMG2: M1 J24: M1 NB diverge to J24 (A453)

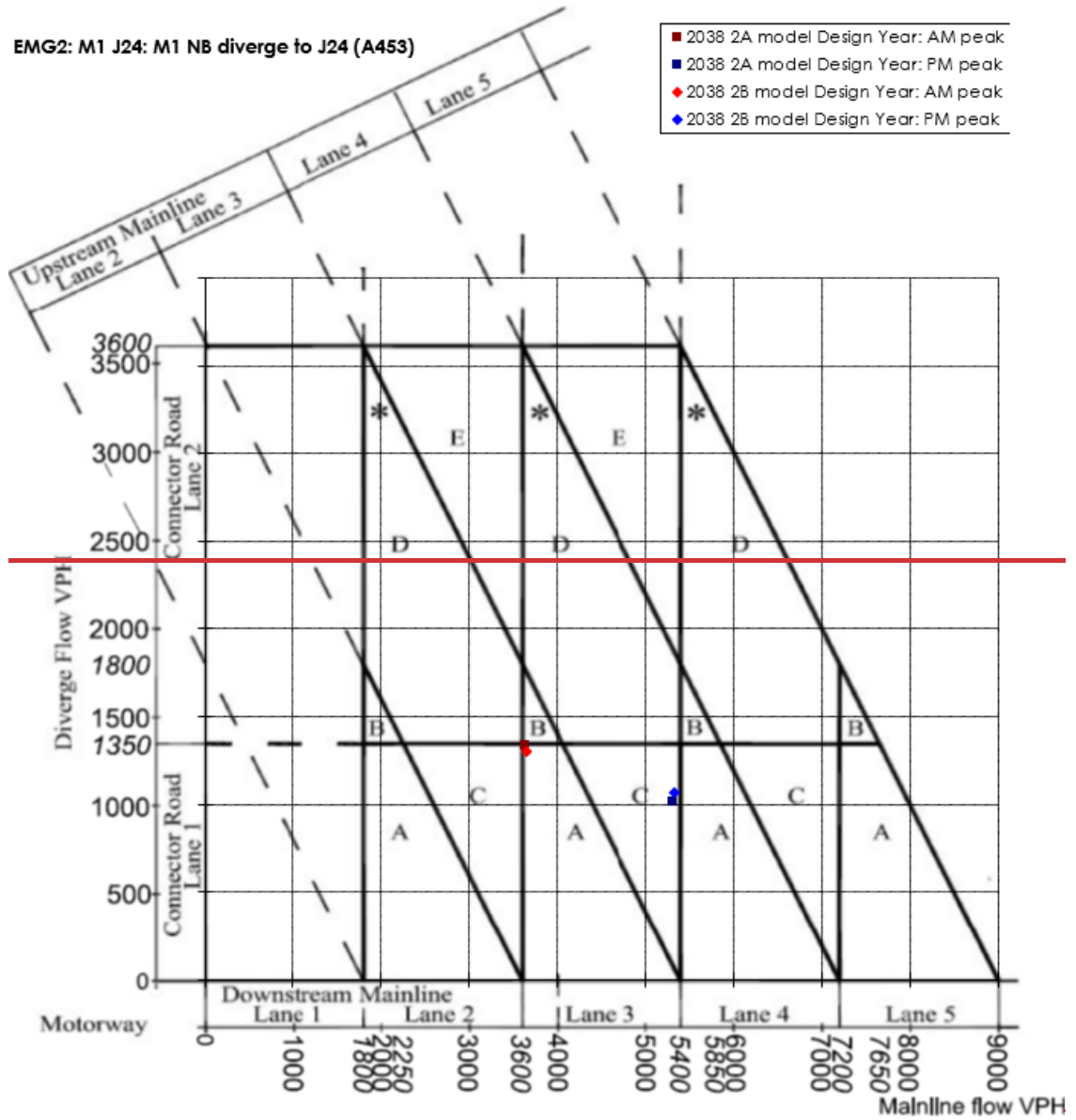

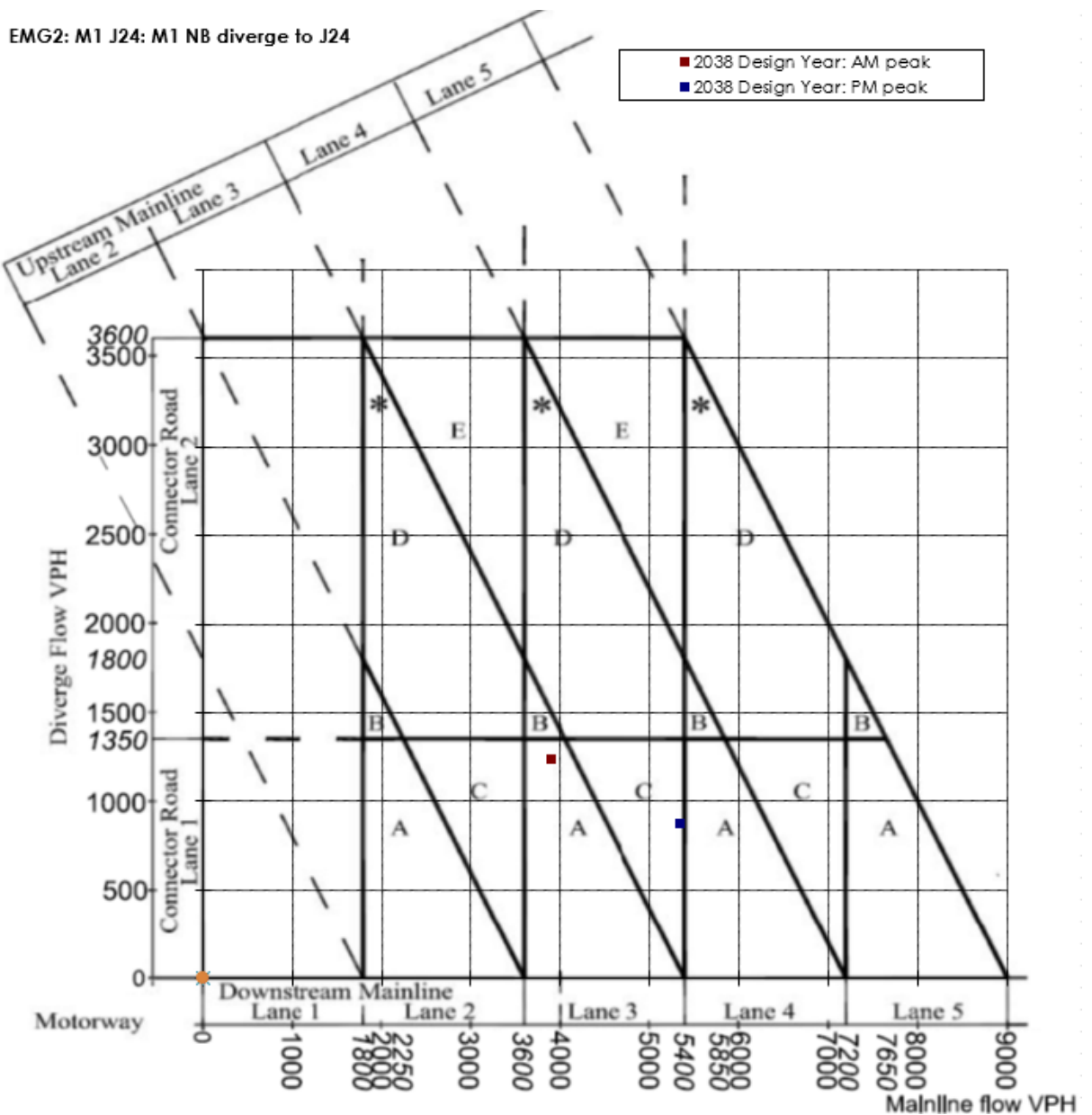

Figure 3.1 M1 J24 northbound diverge layout requirement using traffic data

Design Speed and Geometry

- 3.7 In accordance with CD 122, para 5.4 and Table 5.4, the minimum design speed for a slip road connector shall be 70kph where the mainline design speed is 120kph.
- 3.8 As the mainline alignment is on a left-handed horizontal curve and is not at an up/downhill gradient of 3% or steeper for longer than 1.5km on approach, the use of a Layout A option 1 is not excluded in accordance with CD 122, para 3.28 (further analysis of this is found within section 4).
- 3.9 The geometry of the J24 diverge is shown on **Document DCO 2.8C**.

3.10 The required geometry stated is in accordance with CD 122, para 3.32 and Table 3.32 and is assessed as follows.

- Length of exit taper is 185m and in accordance with the required standard for a two-lane slip road;
- Nose ratio is 1:15 and nose length is 70m. The standard length is 80m. This is an **existing relaxation** from standards based on CD 122, para E/3.7 as 70m is compliant for a 'rural all-purpose 120kph' road class; and
- The maximum width of the hatch marking forming the nose is 4.6m and therefore within the 8m maximum width stated within the Traffic Signs Regulations and General Directions.

3.11 A radius of 1000m is proposed at the edge of the start of the diverge in accordance with CD 122, para 3.32.1.

3.12 Beyond the back of the nose the existing slip road is retained and is therefore not assessed further.

Stopping Sight Distance / Visibility

3.13 As stated within CD 122, para 3.34 mainline SSD shall be provided along the diverge and into the connector road up to the back of the nose.

3.14 CD 109, Table 2.10, states that the desirable SSD for a 120kph design speed is 295m.

3.15 The existing confirmatory gantry (reference GA-01) and the VRS in front restricts visibility into the existing diverge to around 180m minimum SSD. With the revised diverge layout (i.e. amending the diverge to a taper) this will slightly improve the visibility into the diverge but it won't be fully compliant. However, this is an **existing relaxation** from standards based on CD 122, para E/3.9.

Cross Section (Connector Road – Slip Road)

3.16 In accordance with CD 127, para 2.1, Figure 2.1.1N1b provides the required cross-sectional dimensions for a rural motorway connector road.

3.17 Based on predicted vehicle per hour traffic flows for the slip road highlighted above, and in accordance with CD 122, para 5.17 and Table 5.17b, the minimum connector road type is DG1A. However, due to the downstream split of lanes (into four lanes at the traffic signal stop line) the existing cross-section of the slip road is DG2A and it is not proposed to amend this. The two-lanes are marked to the tip of the nose in accordance with CD 127, para 2.19.

Lane Widths

3.18 The cross section of the proposed length of revised slip road at the nose remains as existing with two 3.65m wide traffic lanes.

- 3.19 CD 127, para 2.1 and Figure 2.1.1N1b states for a rural connector road, as well as having a horizontal curvature of greater than 400 metres radius (CD 127, para 2.2 and 5.18), the lanes widths shall be 3.65m wide and accords with the existing connector road lane widths.

Hard Shoulders / Hard Strips / Verges

- 3.20 Connector road type DG2A states that a 1.0m hard strip and 2.5m verge shall be provided on the nearside, and a 1.0m hard strip and 2.0m verge on the offside. These widths are provided at the start of the existing slip road at the back of the nose where the proposed works will tie-in to the existing layout.
- 3.21 From the upstream extent of the nosing for the proposed M1 northbound to A50 westbound interchange link diverge, a 3.3m hard shoulder is proposed on the M1 mainline. It should be noted this improves the existing sub-standard hard shoulder on the M1 nearside.
- 3.22 The mainline hard shoulder tapers into the nearside hard strip on the slip road in accordance with CD 127, para 2.30.
- 3.23 A 1.5m minimum verge width is provided but will be widened as necessary to accommodate relevant assets e.g. motorway communications ducting, lighting, signage, VRS and the like.

4. M1 JCT 24A NORTHBOUND DIVERGE TO A50

Diverge Layout

- 4.1 As noted within section 3 of this report, the scheme proposes a new exit from the M1 to the A50 which would be a direct free-flow link. The new exit would be provided upstream of the existing J24 diverge and downstream of the A42 merge at J23A. This is a weaving section and as such detailed consideration has been given to weaving and the spacing of the two diverges.
- 4.2 The existing J24 diverge is a 2-lane layout B option 1 ghost island diverge, but with the first exit having the form of an auxiliary lane rather than a taper. The diverge layout incorporates the permitted relaxation in the road class to "rural all-purpose 120kph" in accordance with CD 122, para E/3.7, but has a substandard auxiliary lane length which is an existing departure.
- 4.3 At present the first exit is signed for the A50 westbound and the second for the A453 northbound, but both exits come back together on the exit slip road where there is in effect a short weaving section before the stop line, but if drivers take the appropriately signed exit from the M1 then there would be no weaving on the slip road.
- 4.4 Various options have been developed for the layout of the two successive diverges and these are shown diagrammatically, alongside the existing layout, on **drawings EMG2-BWB-GEN-XX-SK-CH-SK032, 033 and 033065**.

Single diverge option (Option B)

- 4.5 Based on CD 122, para 3.36.2, the starting point is to consider a single diverge from the mainline into a connector road, followed by a split into the different destinations. This is shown as Option B on drawing SK032.
- 4.6 Option B would provide a layout B option 1 ghost island diverge and then provide a fork diverge on the exit slip road to separate the A50 westbound traffic and traffic wishing to use the J24 roundabout. However, to create an adequate length for the fork diverge and appropriate geometry leading to the two separate destinations, the diverge would need to move farther south, closer to J23A creating several significant issues with this layout:
 - The existing weaving length would be reduced by around 370m (which would be a departure from standard);
 - It would create a new weaving length on the link between the end of the diverge ghost island and the start of the fork, which would be very short at approximately 189m;
 - There is insufficient space under the Ashby Road overbridge to provide the additional carriageway width needed for the taper (note that even if the diverge layout was amended to the rural all-purpose 120kph road class this would still be the case); and

- Visibility into the diverge would be compromised due to the VRS for the existing A6 Kegworth Bypass and Ashby Road overbridges and would require a departure from standard.

4.7 For the above reasons Option B is not considered feasible and is not considered further.

Two diverges (Options A, C, D, E and DF)

4.8 For these options the proposed scheme will in effect utilise the existing first exit and provide a direct free-flow link from the M1 northbound to the A50 westbound, with the second exit for A453 northbound (and any local) traffic using the J24 roundabout, and could also be used for A50 traffic if required. Hence the two exit points would operate in much the same way as currently, albeit with formal separate diverges.

4.9 For the purposes of this report it is assumed that, in line with the other free-flow links to and from the A50, this exit would be signed as M1 J24A.

4.10 The following table sets out the 2038 design year traffic data for the J24A northbound diverge using the 2A model data:

Location	AM Peak		PM Peak	
	Vehicles	HGVs% HGV	Vehicles	HGVs% HGV
M1 upstream of J24A diverge	62356855	901	76487690	1000
M1 downstream of J24A diverge	49725095	71214.9	63266224	80211.2
Diverge (link to A50)	12631760	189	13221467*	198

~~4.11 The following table sets out the 2038 design year traffic data for the diverge using the 2B model data:~~

Location	AM Peak		PM Peak	
	Vehicles	HGVs	Vehicles	HGVs
M1 upstream of J24A diverge	6301	749	7714	1165
M1 downstream of J24A diverge	4956	546	6396	959
Diverge (link to A50)	1345	203	1318	206

~~* Forecast flow as discussed above.~~

~~4.124.11 Based on CD 122, para 3.9, an adjustment factor for the presence volume of HGVs is not required on downhill gradients or diverge flows.~~

4.134.12 Using the traffic data above, and in accordance with CD 122 para 3.26 and Figure 3.26b, the data has been plotted on **Figure 4.1** below. This suggests a Layout **CD** lane drop with ghost island diverge is required from four to three lanes in the AM peak, and five to four lanes in the PM peak.

EMG2: M1 J24: M1 NB diverge to J24A (A50)

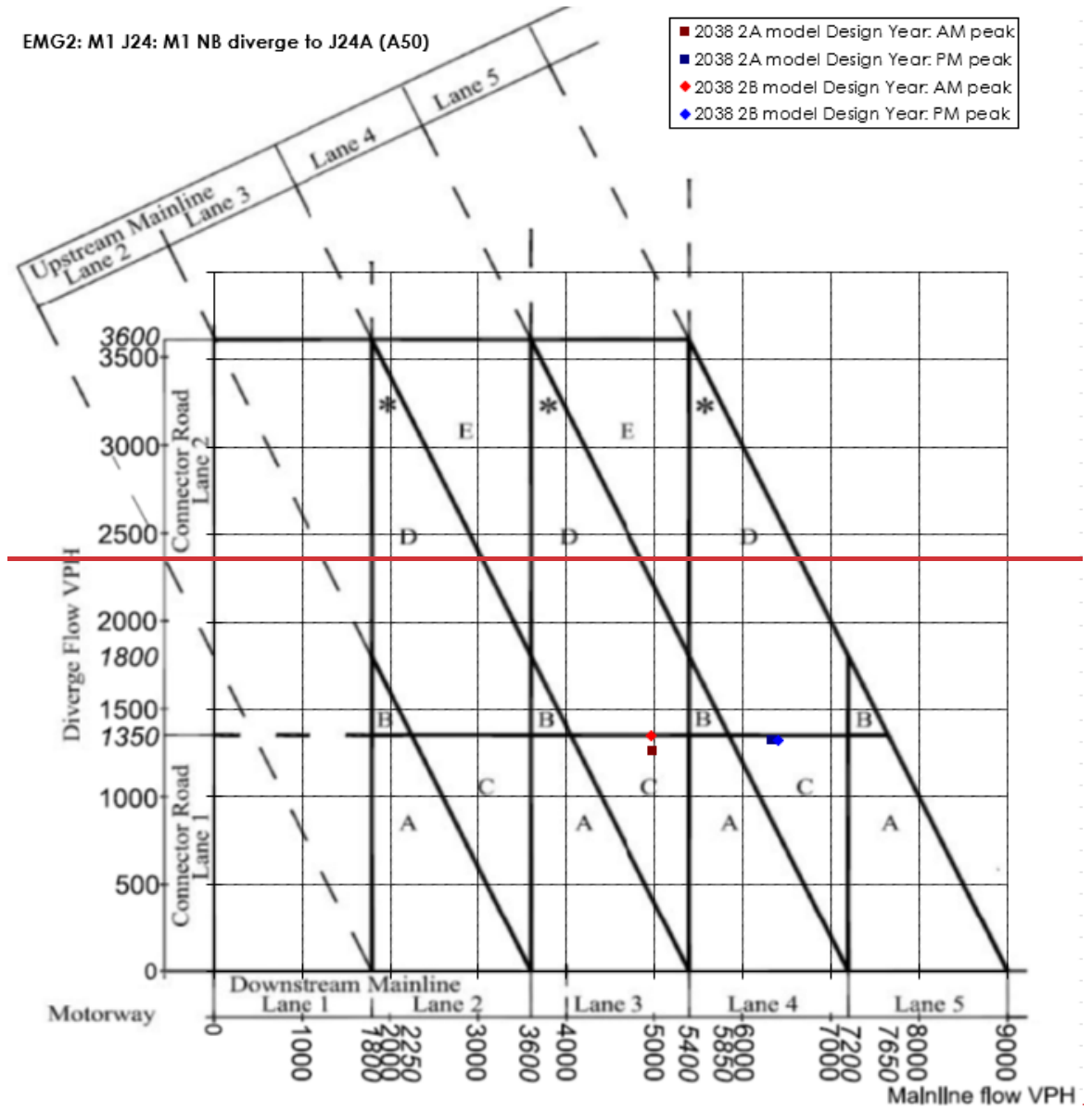

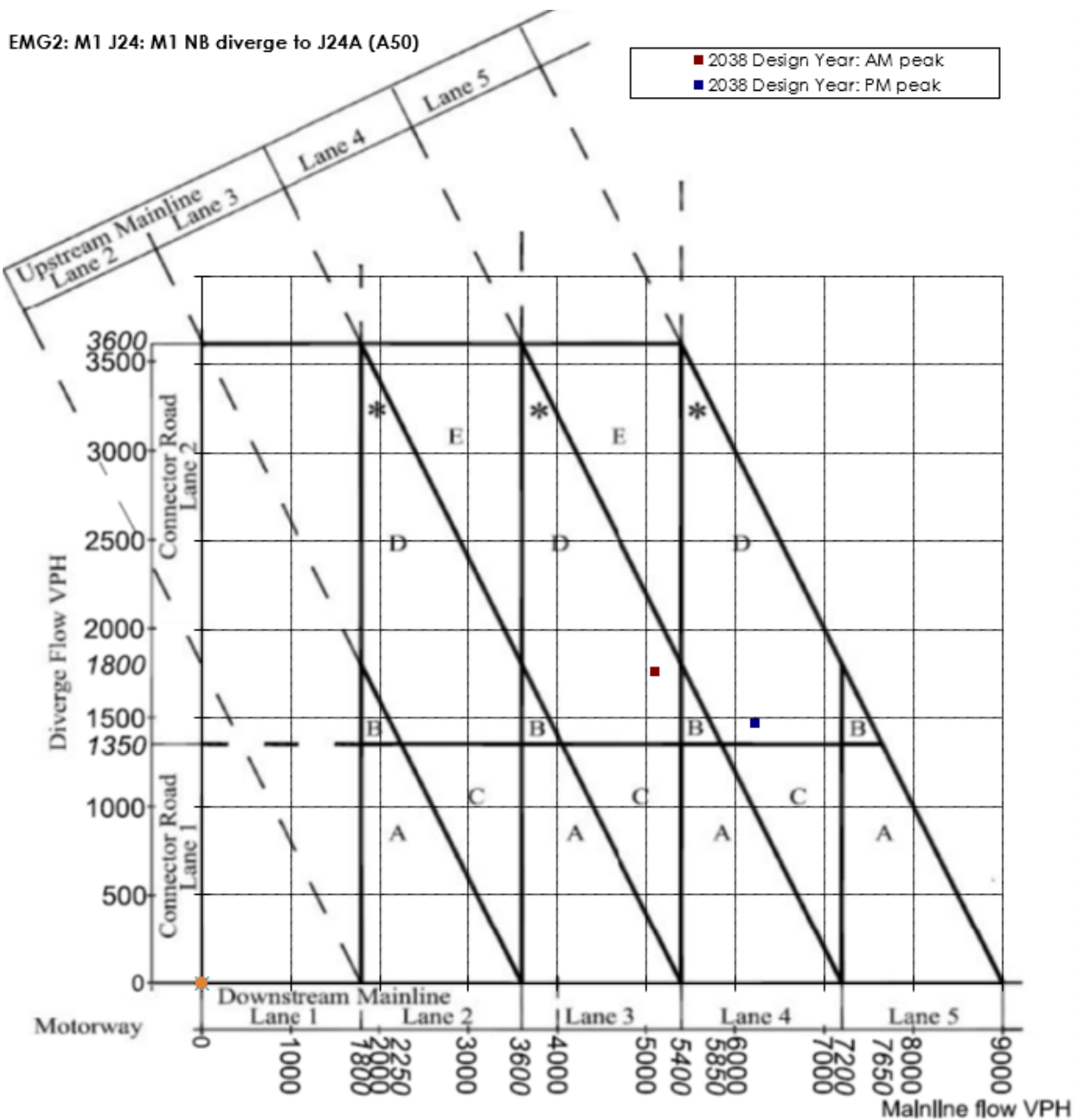

Figure 4.1 M1 J24A northbound diverge layout requirement using traffic data

[4.144.13](#) The M1 northbound at this location is a four-lane Smart Motorway, and the current J24 diverge is the transition point from a four-lane controlled motorway (i.e. with hard shoulder) to four-lane all-lane running (ALR), i.e. without hard shoulder. The smart motorway (constructed around 2018) provides four lanes through J24.

[4.154.14](#) This scheme does not propose to reduce the number of lanes through J24 to achieve the 'layout C lane drop', as would reduce the capacity of the mainline. CD 122, Figure 3.26b demonstrates that as mainline traffic increases and the diverge flow is constant then a layout A would be appropriate regardless. However, the flows are indicating that five lanes are required prior to the diverge and this is discussed below in the weaving analysis as would reduce the capacity of the mainline.

4.164.15 As discussed in detail below, there is a balance to be achieved between the weaving length and spacing of successive diverges. ~~Three~~Five options for the J24A diverge have therefore been developed and are shown on the detailed drawings as follows:

Option	Layout type	Spacing to J24 diverge (m)	Detailed layout shown on drawing EMG2-BWB-GEN-XX-SK-CH-
A	A option 1 (taper)	450	SK034
C	A option 2 (auxiliary lane)	345 (i.e. with Exit Datum Point as Option A)	SK035
D	A option 2 (auxiliary lane)	450	SK036
E	D option 1 (lane drop with ghost island)	345	Not drawn*
F	C option 1 (single lane drop)	450	Not drawn*

* As providing five lanes on the M1 from J23A to J24 is not proposed this diverge layout has not been drawn. The assessment of the number of lanes on the mainline is given below.

4.174.16 The following factors require consideration when assessing the preferred layout:

- Weaving and spacing of successive diverges;
- Visibility (SSD) into the J24A diverge;
- M1 mainline cross-section;
- Provision of directional signs and signalling;
- Visibility of the J24 diverge and associated signing;
- Gradient of the M1 northbound on the approach to the two diverges; and
- Length of the downstream interchange link to the A50.

4.184.17 It is noted that all these options ~~A, C or D can~~ provide the geometrical layout requirements of CD 122, table 3.32 as shown on the drawings listed and therefore the diverge geometry is not a deciding factor.

Weaving and spacing of successive diverges

4.194.18 The M1 northbound between the J23A merge and J24 diverge is an existing weaving section. Using the relevant measuring points in CD 122, the weaving length is 1.8km. This is shorter than the minimum required for a rural motorway, which is 2km (CD 122, para 4.5).

4.204.19 The following table sets out the spacing of the diverges and weaving lengths for the three options and compares them to the existing layout.

Option	Layout type	Spacing to J24 diverge (m)	Weaving length to J24A diverge from J23A merge (m)	Weaving length to J24 diverge from J23A merge (m)
Existing	B option 1 with auxiliary lane	n/a	n/a	1830
A	A option 1 (taper)	450	1547	1982
C	A option 2 (auxiliary lane)	345	1652	1982
D	A option 2 (auxiliary lane)	450	1547	1982
<u>E</u>	<u>D option 1 (lane drop with ghost island)</u>	<u>345</u>	<u>1817</u>	<u>2147</u>
<u>F</u>	<u>C option 1 (single lane drop)</u>	<u>450</u>	<u>1782</u>	<u>2147</u>

4.214.20 As note above the existing J24 diverge is a 'layout B option 1' diverge but with an auxiliary lane for the first (A50) exit. The weaving length is measured to the mid-point of the first exit and ghost island head, as per CD 122. Figure 4.4g, but as discussed above the two exits are signed for different routes which is how the proposed layout with separate diverges would also operate. As such a comparison between the J23A entry datum point and both J24A and J24 exit datum points is also useful when considering the operation of this section of the M1.

Option	Distance from J23A entry datum point to J24A exit datum point (m)	Distance from J23A entry datum point to J24 exit datum point (m)	Distance from J23A entry datum point to J24 (2 nd exit) taper (m)	Change from existing J23A-J24 to proposed J23A-J24A (m)	Change from existing to proposed J23A-J24 exit datum (m)	Change from existing to proposed J23A-J24 exit taper (m)
Existing	n/a	1437	1812	n/a	n/a	n/a
A	1342	1777	n/a	-95	+340	-35
C	1342	1777	n/a	-95	+340	-35
D	1237	1777	n/a	-200	+340	-35
<u>E</u>	<u>1347</u>	<u>2057</u>	<u>n/a</u>	<u>-90</u>	<u>+620</u>	<u>+245</u>
<u>F</u>	<u>1592</u>	<u>2057</u>	<u>n/a</u>	<u>+155</u>	<u>+620</u>	<u>+245</u>

4.224.21 As can be seen from the above the provision of the new J24A diverge would be closer to the J23A merge but only by 95m for options A and C. In ~~all~~ options A, C and D the distance between the J23A entry datum point and J24 exit datum point increases by 340m in absolute terms, but reduces by 35m in terms of the exit taper and this is due to the proposed J24 taper being to motorway road class whereas the existing is relaxed to the 'rural all-purpose 120kph' road class. For Options E and F the distance between the J23A entry datum point and J24 exit datum point increases by 620m.

4.234.22 CD 122 para 3.36 requires a minimum distance of 3.75Vm between the tips of successive noses, where V is the design speed of 120kph, giving a minimum distance of 450m. The table below shows the spacing of the diverges for each option and gives the corresponding distance between the exit datum points.

Option	Distance between tips of noses J24A to J24 (m)	Distance between successive exit datum points J24A to J24 (m)
A	450	435
C	345	435
D	450	540
E	<u>345</u>	<u>710</u>
F	<u>450</u>	<u>465</u>

Summary

4.244.23 In summary the proposed layout providing two separate diverges will operate in a similar way to the existing diverge, given that at present the first exit is signed for the A50 and the second exit for the A453.

4.254.24 Option C is preferable in terms of maximising the weaving length- assuming five lanes cannot be provided (see below). As the existing weaving length is reduced in all options then as CD 122, para E/3.11 does not apply and this is a **departure**, reference **G1**.

4.264.25 Options A, D and DF are preferable over option C in terms of providing the standard distance between two successive exits. Option C would be a **departure**, reference **G2**.

4.26 The diverge layout Option C would be a **departure**, reference **G13**.

Weaving section number of lanes

4.27 As noted above CD 122 para 4.7 requires the use of equation 4.7. However, equation 4.7 requires that the Lmin is 2km (for a motorway as per CD 122 para 4.5) and the Lact "is never less" than Lmin but the existing weaving length is already below 2km. The equation does not say how to assess a weaving length to two separate exits.

4.28 As such it is not straightforward to undertake the calculation for the M1 J23A-24 northbound using this equation. Therefore a series of calculations (for both AM and PM peak hours) have been undertaken based on varying the following:

- Lmin (below 2km)
- Lact
- If the weaving flow to the diverge is the traffic seeking the first diverge or the total of both diverges

4.29 CD 122 para 4.7 Note 2 states that "For the purpose of the calculation the 'available weaving length' is never less than the 'minimum weaving length'. The minimum weaving length for a motorway is stated as being 2km (CD 122 para 4.5). However, given that the existing and proposed weaving lengths (i.e Lact) are both below 2km, the value of Lmin used cannot be 2km.

4.30 To understand the variability Lmin has on the calculations two methods have been used. The first is using a value of 1km which is for all-purpose roads and it is not known why this can be 1km for the same speed of road, yet a motorway is 2km. The second is where CD 122 figure 4.6b has been used, this is because CD 122 para E/3.11.2 infers that this determines the minimum weaving length for a section of smart motorway. Using the traffic data the minimum values of Lmin would therefore be calculated as follows:

4.274.31 CD 122, equation 4.7 applies to smart motorways as well as standard motorways. As the weaving length is reduced below the existing, and is below the 2km minimum, the actual weaving and minimum lengths are set in the calculation to be the same value, thus meaning the weaving length doesn't impact the calculation (as per CD 122, para 4.7 note 2).

4.28 CD 122 does not however specifically state how to assess the numbers of lanes within a weaving length where there are two downstream exits. Therefore, two calculations have been undertaken:

- Weaving lane calculation to the first (J24A) exit with traffic to the downstream (J24) assumed to be on the mainline; and
- Weaving lane calculation using the total of J24A and J24 exits as exiting traffic.

4.29 The results of the above are shown below. The number of lanes have been calculated for the two scenarios as follows:

Scenario	Traffic model CD 122 Figure 4.6b minimum weaving length (m)	
	AM	PM
To first (Based on J24A) exit diverge flow only	2038-2A-640	4.52930
To both exits	2038-2A	4.75 6.01
To first (Based on J24A) exit only+J24 diverge flow	2038-2B-770	4.561150
To both exits	2038-2B	4.84 6.14

4.30 The results above highlight that the scenario for 'both exits' is more onerous than for 'J24A only' with the PM peak hour being more onerous still. There is little difference between the 2A and 2B scenarios.

4.32 It is not proposed as part of the scheme The value of Lact is determined as follows in each case:

Scenario	Reference points for Lact	Lact (m)
Based on J24A diverge flow only	J23A merge (CD 122 figure 4.4c) to J24A diverge (CD 122 figure 4.4f)	1.7

Based on J24A+J24 diverge flow	J23A merge (CD 122 figure 4.4c) to midway between J24A and J24A diverges - this is similar to how CD 122 would define the weaving length for a diverge with two exit points and a ghost island	1.87
--------------------------------	--	------

4.33 The number of lanes in the weaving length is therefore calculated for the following scenarios (the PM value from the above for Lmin is used being the more onerous case):

Scenario	Lmin (m)	Lact (m)	AM	PM
Based on J24A diverge flow only	1000	1700	4.5	5.2
Based on J24A diverge flow only	930	1700	4.4	5.1
Based on J24A+J24 diverge flow	1000	1870	4.6	5.4
Based on J24A+J24 diverge flow	1150	1970	4.8	5.6

4.34 Using the methodology stated in CD 122 paras 4.7.1 and 4.7.2 five lanes would be required in three of the four scenarios assessed in both AM and PM peak hours. One AM scenario suggests four lanes whilst one PM scenario suggests that six lanes are required. As noted elsewhere the M1 northbound within J23A has three lanes and the A42 two lanes, so there would be a maximum of five lanes feeding into the weaving section. On this basis it is taken that using the calculations, five lanes should be provided to be compliant with CD 122 para 4.7.

4.31.4.35 Options A, C and D do not propose to provide five lanes from the J23A merge to J24A (or J24) diverge and this is a **departure**, reference **G3** (applying to all options A, C and D). We note that provision of five lanes is in itself not a departure from CD 127, para 2.15, as an additional lane over this length would be an auxiliary lane.

4.36 Options E and F would provide five lanes but are not proposed to be taken into the scheme due to the additional cost, disruption and environmental impacts. The safety risk assessment to GG 104 (found at **Appendix 2**) does not show a discernible safety benefit to providing five lanes principally due to a five lane carriageway increasing the likelihood of a live lane breakdown (due to the increased distance between the hard shoulder and farthest traffic lane from it).

4.32 CD 122 para E/1.83.11.2 states that where the weaving length on an existing motorway is less than the length derived from CD 122 Figure 4.6b, options for reducing or eliminating weaving should be assessed and implemented where practicable. The minimum weaving lengths derived from CD 122 Figure 4.6b are as follows:

Scenario	Traffic model	CD 122 Figure 4.6b minimum weaving length (m)	
		AM	PM
To first (J24A) exit only	2038-2A	510	640
To both exits	2038-2A	640	770
To first (J24A) exit only	2038-2B	510	650
To both exits	2038-2B	660	780

[4.334.37](#) As can be seen the proposed weaving length in all options is higher than the minimum required by this figure and therefore options to reduce or eliminate weaving do not need to be considered further.

[4.344.38](#) VISSIM modelling has been undertaken to fully assess the impact of the weaving on the traffic flow ~~and the VISSIM.~~ This modelling does not identify any demonstrates that the M1 J23A-24 northbound weaving section is predicted to operate significantly better in the with EMG2 development and SRN mitigation scheme scenario than in the future without the EMG2 development and SRN mitigation scheme. In the scenario without the EMG2 development and SRN mitigation scheme the entire section of the M1 northbound from J23A to J24 is predicted to have significant queuing throughout the AM peak hour. The modelling for the with EMG2 development and SRN mitigation scheme (and based on the design incorporating this departure) shows that there could be some flow breakdown over the weaving length in the area of the J23A merge in the PM peak hour only.

Visibility (SSD) into the J24A diverge

[4.354.39](#) In accordance with CD122, para 3.34, the visibility into the diverge to mainline SSD (i.e. 295m based on 120kph design speed) up to the back of the nose shall be achieved.

[4.364.40](#) For the proposed J24A (A50) diverge the SSD into the diverge is restricted by the Ashby Road overbridge and the VRS in front of the bridge. For the three options the SSD into the diverge reduces as set out in the table below. This is based on the driver and object heights stated (note the 1.05m eye height is considered to be the most onerous case).

Eye height (m)	Object height (m)	Option A min SSD (m)	Option C min SSD (m)	Option D min SSD (m)
1.05	0.26	261	251	171
1.05	1.05	292	287	254

[4.374.41](#) From the above, whilst none of the options are fully compliant, it can be seen that options A and C are substantially more compliant than option D. The reduction below desirable minimum SSD into the diverge is **departure**, reference **G4**. Options E and F are not considered as they require five lanes between J23A and J24.

M1 mainline cross-section

[4.384.42](#) At present between M1 J23A and Ashby Road overbridge (just before the start of the J24 diverge), the M1 northbound is a D4M cross-section with above-lane signals, making it a controlled motorway. From Ashby Road overbridge the hard shoulder is discontinued as this initially is used to form the J24 diverge. Then downstream of the diverge becomes lane 1 of the D4-ALR motorway leading north to J25.

[4.394.43](#) For the new J24A diverge layout for the A50, and amended J24 diverge, and with land available for the scheme, a hard shoulder can be re-instated from a point north of the Ashby Road overbridge up to the J24 diverge (where the hard shoulder

tapers over the length of the diverge nose, as a hard shoulder is not required on the J24 slip road).

4.404.44 The re-instated hard shoulder would provide an improvement, significantly reducing the potential for a stopped vehicle to be present within the live lanes of the diverge as vehicles would be able to pull off to the side onto the hard shoulder.

4.414.45 The re-instatement of the hard shoulder can be achieved by all ~~three~~ five options A, C, D, E and F.

Provision of directional signs and signalling

Directional signs

4.424.46 CD 146 sets out the requirements for directional signing. The locations of directional signs are based on the exit datum point for the diverge. With the change to the diverge layout i.e. providing two separate diverges, there will be two different exit datum points (ExDP) and both need to be checked for compliance against CD 146.

4.434.47 The table below reviews the signing sequence for ~~each option~~ options A, C and D and compares this to the existing layout and identifies any departures from standard that may be required.

Sign type	CD 146 requirement	Option	J24A exit	J24 exit
Confirmatory sign	30-50m downstream of tip of nose	Existing	n/a	Gantry GA-01 90m beyond tip of nose Existing departure
		A, C or D	30 downstream of tip of nose Compliant	As existing (sign changed on existing gantry GA-01) Existing departure
Final direction sign	0-50m upstream of ExDP	Existing	n/a	Gantry GA-02 105m downstream of the ExDP Existing departure
		A and C	Gantry GA-03* 377m upstream of ExDP Departure S1	New Gantry GA-01A At ExDP Compliant
		D	Gantry GA-03* 272m upstream of ExDP Departure S1	
Secondary direction sign	½ mile or ½ mile or ⅔ mile with tolerance +10% -20m	Existing	n/a	Gantry GA-03 ½ mile, 472m upstream of the ExDP, 44m out of tolerance Existing departure
		A and C	Gantry GA-04 ½ mile, 907m upstream of ExDP, 22m out of tolerance	Gantry GA-03 ½ mile, 812m upstream of ExDP

Sign type	CD 146 requirement	Option	J24A exit	J24 exit
			Departure S2	Compliant
		D	Gantry GA-04 ½ mile, 802m upstream of ExDP Compliant	**see below regarding gantry GA-04
Primary direction sign	⅔ mile, 1 mile or 1⅓ mile with tolerance +10% -20m or 1¼ mile with tolerance +115m -20m	Existing	n/a	Gantry GA-04 ⅔ mile, 1002m upstream of the ExDP, 51m out of tolerance Existing departure
		A and C	New Gantry GA-04A ⅔ mile, 1174m upstream of ExDP Compliant	New Gantry GA-04A 1 mile, 1609m upstream of ExDP Compliant
		D	New Gantry GA-04A ⅔ mile, 1609m upstream of ExDP Compliant	

* Gantry GA-03 is upstream of the A6 Kegworth Bypass and Ashby Road overbridges and it is not possible to locate a gantry between these bridges and the ExDP as it would be obscured by the bridges. Subject to non-prescribed sign authorisation it may be beneficial to provide a distance plate in yards to the J24A ExDP.

** Gantry GA-04 would also be used to provide signage for the J24 exit, and this would be an additional secondary direction sign. It is located 1342m upstream of the ExDP and the distance ¾ mile would be most suitable. ¾ mile is 1207m and plus 10% is 1328m so it would be 14m out of tolerance upstream. ¾ mile is not permitted in CD 146 but is permitted in the traffic signs regulations. It would therefore require a **departure**, reference **S3**.

[4.444.48](#) It should be noted that none of the four existing J24 exit gantries are in compliant locations. This can be improved with any of the proposed layout options.

[4.454.49](#) The most compliant option for directional signing is Option D as all of the signs for J24A would be in compliant locations except for the final direction sign. The signing to J24 would be the same in all three options.

[4.464.50](#) In options A and C the spacing between the J24A confirmatory sign on gantry GA-02A and J24 final direction sign on gantry GA-01A is 236m. In option C this is reduced to 130m. Traffic Signs Manual Chapter 7 Appendix E sets out that for 70mph roads minimum clear visibility of 180m to signs is required, with a greater distance recommended. Option C does not meet this minimum standard for the J24 final direction sign on gantry GA-01A as it would be partially obscured by the upstream gantry GA-02A.

Signalling

[4.474.51](#) The existing motorway signalling is above-lane signals (ALS) between the J23A merge and J24 diverge completed by VMS. These were originally provided when this

section of the M1 was widened in the early 1990s for the A42 scheme. They were then upgraded during the smart motorway project (SMP) in the late 2010s to mandatory signals (VMSL) using the original gantries. This means that there are some **existing departures** for ALS as follows:

- The first ALS after the J23A merge are located 435m downstream of the entry datum point (they should be between 200 and 400m, CD 146 para 4.17); and
- The confirmatory ALS after the existing J24 diverge are located 90m downstream of the tip of the diverge nose (they should be between 30 and 50m, CD 146 para 4.19).

4.484.52 Options A, C and D would change the ALS provision as follows:

- The new Gantry GA-04A would provide ALS as it would become the new First ALS after the J23A merge. As it would be located 168m downstream of the J23A entry datum point it would be a **departure S4** (superseding the existing departure).
- The existing final direction sign gantry GA-02 (which has ALS) would be removed;
- A new final direction sign gantry GA-01A would be provided with ALS for the J24 diverge; and
- ALS is not proposed for new confirmatory gantry GA-02A on the basis that this is very close to the proposed GA-01A and the upstream gantry would obscure the downstream one if it was extended across the motorway to provide ALS. This would be a **departure S5**.

4.494.53 Overall there would be a net increase of one set of ALS for all ~~three~~ options A, C and D.

4.504.54 Variable message signs (VMS) are provided in addition to the ALS. There are various existing departures for VMS as follows:

- VMS are co-located with ALS, exit directional signs and ahead directional signs on the primary signage gantry (they should be between 200 and 400m upstream, CD 146 para 4.25); and
- VMS are co-located with ALS, exit directional signs and ahead directional signs on the secondary signage gantry (they should be between 200 and 400m upstream, CD 146 para 4.26).

4.514.55 For Options A, C and D the provision of an additional confirmatory sign for J24A means that VMS would be provided on the confirmatory gantry in accordance with CD 146 para 4.27. The existing final direction signage gantry GA-02 for J24 would be removed but this does not provide a VMS at present. No other changes to VMS would be proposed with the above existing departures retained. Hence there would be a net increase of one VMS.

4.524.56 As discussed above for the directional signage, options A, C and D introduce a new primary directional signage gantry (GA-04A). This means that a VMS is required between 200 and 400m upstream of this gantry, but this is within the area of the J23A merge. An existing VMS is present 773m upstream of the proposed gantry and this would be the primary VMS. This would, however, be a **departure S6**.

Visibility of the J24 diverge

[4.534.57](#) Aside from the existing relaxation associated with the existing gantry GA-01 discussed at section 3 above, the visibility into the J24 diverge is compliant with CD 122 and the proposed final gantry GA-01A does not reduce visibility into the diverge below the required 295m. Therefore visibility into the J24 diverge does not affect the choice of options.

Gradient of the M1 on the approach to the two diverges

[4.544.58](#) CD 122 para 3.28 sets out requirements where a layout A option 2 (auxiliary lane) diverge is to be used in lieu of a layout A option 1 (taper) diverge. Options C and D consider auxiliary lanes and option A is a taper.

[4.554.59](#) The mainline is on a gradual left-hand radius so the consideration for using an auxiliary lane is the gradient before the diverge. The following table sets out the levels in mAOD at 500m intervals prior to the ExDP for each diverge.

Level (mAOD) at Location	J24 diverge	J24A diverge
ExDP	51.3	63.9
500m prior to ExDP	65.7	73.7
1km prior to ExDP	74.5	77.5
1.5km prior to ExDP	77.5	74.7

[4.564.60](#) Based on the above the average gradients are calculated:

Average gradient	J24 diverge	J24A diverge
Over 500m before ExDP	2.9% downhill	2.0% downhill
Over 1km before ExDP	2.3% downhill	1.4% downhill
Over 1.5km before ExDP	1.7% downhill	0.7% downhill

[4.574.61](#) It can be seen from the above that the gradient is less than 3% on the 1.5km approach to both diverges, and does not go above 3% average on the 500m before the diverge, and there is therefore no requirement to provide an auxiliary lane.

Length of the downstream interchange link to the A50

[4.584.62](#) Based on the forecast traffic flows for the M1 northbound to A50 westbound interchange link (see detail provided at section 5 below), a minimum cross-section of ~~IL1A~~IL2A is required. However, a cross-section of IL1A is proposed. CD 122 para 5.3 does not permit single-lane interchange links of greater than 1km. Depending on the options for the bridge on the interchange link over or under the A453 (see section 5 below) and the M1 northbound diverge options discussed here the link may or may not be greater than 1km. The following table gives a summary of this.

Bridge Option	Link length for Diverge option A or D (km)	Link length for Diverge option C (km)
1 or 2A/2C	1.0	0.9
2B/2D	1.05	0.95
No. lanes required on interchange link	2	1
Minimum cross-section	IL2A	IL1A

4.594.63 ~~As discussed above a single lane diverge is required for the M1 northbound to A50 westbound diverge.~~ Based on the A50 westbound merge layout a single lane gain at the merge is required and it would not be possible to provide a two-lane merge. Hence a single lane prior to the merge is required.

4.604.64 The first 200m or so of the interchange link in options A and D is located between the M1 mainline and the A453. This is a tight corridor and it is not considered feasible to provide a two-lane interchange link to cross section IL2A within the available space. Hence options A and D would require a departure from standard ~~reference G5~~ for the provision of a single-lane interchange link in excess of 1km.

4.65 Options E and F would provide a two-lane diverge into an interchange link of cross-section IL2A.

Summary and preferred option

4.614.66 The following table sets out a summary of each aspect considered above. Options B, E and F are not considered viable for the reasons set out above and are therefore not included in this summary.

Consideration	Preferred option	Summary of reasoning
Weaving	C then A then D	Option C Maximises weaving length
Spacing of successive diverges	A or D	Provides standard spacing between exits
Visibility (SSD) into the diverge	A or C	Options A and C although not fully compliant are significantly better than option D
M1 mainline cross-section	A, C or D	All options allow for re-instatement of the hard shoulder north of the Ashby Road bridge to the J24 diverge
Provision of directional signing	D then A then C	Higher level of compliance with CD 146 is achieved with option D Option C final direction sign for J24 partially obscured by the upstream gantry.
Provision of signalling	A, C or D	Net increase of one ALS and one VMS in all options, no discernible differences between the options

Consideration	Preferred option	Summary of reasoning
Visibility of the J24 diverge	A, C or D	No discernible difference
Gradient of the M1 on the approach to the two diverges	A	There is no requirement in gradient terms to us an auxiliary lane
Length of the downstream interchange link to the A50	C	Option C allows for a single-lane interchange link as the length is less than 1km

4.624.67 From the above it is clear that there are advantages and disadvantages with all options. However, aside from the directional signing, option D performs least well, and option D is significantly worse when considering visibility into the diverge.

4.634.68 A scoring system has therefore been used to assess the various issues with a score of 1 (least preferred) to 3 (most preferred). A score of 0 is used if all options are the same.

Consideration	Option A score	Option C score	Option D score
Weaving	2	3	1
Spacing of successive diverges	3	1	3
Visibility (SSD) into the diverge	3	3	1
M1 mainline cross-section	0	0	0
Provision of directional signing	2	1	3
Provision of signalling	0	0	0
Visibility of the J24 diverge	0	0	0
Gradient of the M1 on the approach to the two diverges	0	0	0
Length of the downstream interchange link to the A50	1	3	1
Total	11	11	9

4.644.69 From the above options A and C score best, followed by D. Of the above, weaving, spacing of successive diverges and visibility into the diverge are key user safety issues. As noted above option D performs notably worse for visibility into the diverge and for this reason it is discounted.

4.654.70 The key decision therefore is between maximising the weaving length (option C) vs the compliant spacing of successive diverges (option A).

4.71 To inform the decision-making process a safety risk assessment assessments to GG 104 has have been undertaken which is are found at Appendix Appendices 1— and 2. These risk assessments consider:

- Weaving length and spacing of diverges; and
- Number of lanes in the weaving length and the diverge type.

[4.664.72](#) This has reviewed the risks in the existing layout against those for the proposed options A and C. In particular this has reviewed risks associated with weaving and closely spaced exits. The conclusion of this work is that Option C presents the least risk, with the main differentiating factor being the risks associated with 'swooping' (i.e. drivers trying to exit at the last moment) is lower in Option C because it has an increased weaving length. The risk assessment has included mitigation measures for improving the signage and signalling over the weaving section over and above the current layout.

[4.674.73](#) Therefore **Option C** is to be progressed.

Further measures to maximise weaving length

[4.684.74](#) CD 122 para E/1.8.1 states that "The weaving length to be provided on an existing motorway should be as close as practicable to the requirements of CD 122".

[4.694.75](#) Whilst the layout of the J24 and J24A diverges have been discussed in detail above, the other reference point for weaving length is the upstream merge at J23A from the A42 which is a layout E option 1 merge.

[4.704.76](#) A review of the existing merge layout has been undertaken and it has been determined that the existing merge layout nose, taper and ghost island tail, all exceed the lengths required by CD 122 which constitute **existing departures** from para 3.21. The table below summarises the existing lengths against CD 122 table 3.21.

Element	Existing merge (m)	CD 122 requirement (m)
Nose	150	115
Taper (lane 2 merge taper)	220	205
Ghost island tail	205	180

[4.714.77](#) Adjusting the merge layout such that it complies with standard will reduce the footprint of the merge, thus moving the entry datum point and the point from which weaving is measured (at the end of the lane two entry taper as per CD 122 figure 4.4c) south, away from J24 and thereby increasing the weaving length. The weaving length can be increased by 50m and the distance between J23A entry datum point and J24A exit datum point increased by 75m.

[4.724.78](#) As this amendment to the merge is a relatively straightforward intervention which clearly aligns with CD 122 para E/1.8.1, this has been implemented into the design. This revised option is referred to as **Option C++** and is shown diagrammatically on drawing [EMG2-BWB-GEN-XX-SK-CH-SK065](#).

[4.734.79](#) The geometry of the J24A diverge Option C is shown on **Documents DCO 2.8B and DCO 2.8C**.

[4.744.80](#) The following tables show the comparison between weaving lengths and spacing of datum points.

Option	Weaving length (m)
Existing	1830
CD 122 minimum standard	2000
C	1652
C+	1702

Option	Distance from J23A entry datum point to J24A exit datum point (m)	Distance from J23A entry datum point to J24 exit datum point (m)	Distance from J23A entry datum point to J24 (2 nd exit) taper (m)	Change from existing J23A-J24 to proposed J23A-J24A (m)	Change from existing to proposed J23A-J24 exit datum (m)	Change from existing to proposed J23A-J24 exit taper (m)
Existing	n/a	1437	1812	n/a	n/a	n/a
C	1342	1777	n/a	-95	+340	-35
C+	1417	1852	n/a	-20	+415	+40

[4.754.81](#) It can be seen from the above that option C+ would result in a 20m reduction in distance between the successive entry and exit datum points on the motorway.

[4.764.82](#) Option C+ will also have a beneficial impact on the following aspects:

- The length of the existing M1 mainline hard shoulder discontinuity at the J23A merge can be reduced in length; and
- The distance between the J23A entry datum point and new gantry GA-04A is 243m which is **compliant** to CD 146 as a 'first' gantry and therefore the departure S4 is not required.

Departures From Standard

[4.774.83](#) **Appendix 34** provides a summary of the road layout departures from standard within this section which apply to option C+ and provides their current approval status.

5. M1 NORTHBOUND TO A50 WESTBOUND INTERCHANGE LINK

Layout

- 5.1 The scheme proposes to provide a direct (free-flow) link between the M1 northbound and the A50 westbound. At present this movement takes place using the J24 roundabout or via J23A and the A453 parallel to the M1. All the other movements between the M1 and A50 are already direct free-flow links.
- 5.2 The new link is termed the M1 Northbound to A50 Westbound interchange link which is a type of connector road under CD 122.
- 5.3 Five options are under consideration for this link which relate to how it crosses the A453, namely if it goes under or over. The three geometrical options are:
- Option 1B/1C: Underbridge;
 - Option 2A/2C: Three-span overbridge with crest curve K17; and
 - Option 2B/2D: Single-span overbridge with crest curve K30.
- 5.4 The structures options report recommends that options 2B/2D (single span overbridge) should be pursued, with the choice of option 2B or 2D depending on the outcome of the geometrical assessment contained in this report. To inform the decision-making process a safety risk assessment to GG 104 has been undertaken which is found at **Appendix 2**.

Traffic flows

- 5.5 The following table sets out the design year traffic data for the interchange link.

Location	AM Peak		PM Peak	
	Vehicles	HGVs% HGV	Vehicles	HGVs% HGV
M1 NB to A50 WB Interchange link	1341 1752	2149.1	1176 1766	1768.8

- 5.6 The numbers provided above are the ultimate demand flows and in the PM peak are higher than the data is extracted from the VISSIM model which for the diverge in the PM peak hour which is 1467 vehicles. This is due to the slight delay in the PM model at J23A where due to the high mainline flow, the A42 merge has a slight delay for vehicles merging on the M1 NB. However, this aspect is assessed using the ultimate demand flow as it could be the upstream constraint is resolved by another scheme in the future.

Design Speed and Geometry

- 5.6.5.7 As noted above this is considered as an interchange link. Therefore, the design speed in accordance with CD 122, para 5.4, and Table 5.4 for a rural mainline design speed of 120kph is 85kph.

Horizontal alignment

5.75.8 The horizontal alignment for each option is summarised as follows:

Option	1B/1C	2A/2C	2B/2D
Description	<ul style="list-style-type: none"> Near straight after diverge compliant to CD 122 Left hand radius 720m (minimum R with 3.5% superelevation) Transition Straight Right hand radius 1440m (minimum R with adverse camber and without transitions) Near straight before merge compliant to CD 122 	<ul style="list-style-type: none"> Near straight after diverge compliant to CD 122 Left hand radius 720m (minimum R with 3.5% superelevation) Transition Straight Transition Left hand radius 720m (minimum R with 3.5% superelevation) Transition Straight Transition Right hand radius 720m (minimum R with 3.5% superelevation) Near straight before merge compliant to CD 122 	<ul style="list-style-type: none"> Near straight after diverge compliant to CD 122 Left hand radius 720m (minimum R with 3.5% superelevation) Transition Straight Transition Left hand radius 720m (minimum R with 3.5% superelevation) Transition Straight Transition Right hand radius 720m (minimum R with 3.5% superelevation) Near straight before merge compliant to CD 122
Compliance with DMRB	Compliant	Compliant	Compliant

Vertical alignment

5.85.9 The vertical alignment for each option is summarised as follows:

Option	1B/1C	2A/2C	2B/2D
Description	<ul style="list-style-type: none"> Grade 4.6% downhill Sag K 27 Grade 2.05% uphill Crest K 55 	<ul style="list-style-type: none"> Grade 6% downhill Sag K 20 Grade 6% uphill Crest K 17 (two steps below desirable minimum) Grade 6% downhill Sag K 20 	<ul style="list-style-type: none"> Grade 6% downhill Sag K 20 Grade 6% uphill Crest K 30 (one step below desirable minimum) Grade 6% downhill Sag K 20
Compliance with DMRB	Compliant	The use of a crest K of 17 is a departure reference G4G7 on the basis that CD 122 does not permit relaxations below desirable minimum (in this case K 55) on connector roads.	The use of a crest K of 30 is a departure reference G4G7 on the basis that CD 122 does not permit relaxations below desirable minimum (in this case K 55) on connector roads.

[5.95.10](#) Although Option 1B/1C has compliant vertical alignment geometry, the levels of the new link road would be over 7m below existing ground level. The level goes beyond the level of the adjacent M1 drainage and there is therefore no positive drainage outfall. A surface water pumping station would be required which imposes a long-term maintenance burden on National Highways and poses a safety risk to road users in the event of flooding.

[5.105.11](#) Option 2B/2D is visually less intrusive being slightly lower in overall elevation and a longer crest meaning it is not as pronounced.

Stopping Sight Distance / Visibility

[5.115.12](#) The desirable minimum SSD for 85kph, i.e. 160m, is achieved throughout for Option 1B/1C.

[5.125.13](#) ~~Options 2A and 2B~~ In the other options the use of a crest K below desirable minimum introduces a reduction in the SSD.

[5.135.14](#) The minimum SSD for each option is therefore assessed as follows:

Option	1B/1C	2A/2C	2B/2D
Description	Minimum SSD of 160m achieved throughout	Minimum SSD: <ul style="list-style-type: none"> to low object height of 90m (two steps below desirable minimum) to 1.05m object height of 120m (one step below desirable minimum) Minimum SSD of 160m achieved within the immediate approach to the downstream merge.	Minimum SSD: <ul style="list-style-type: none"> to low object height of 120m (one step below desirable minimum) to 1.05m object height of 160m Reduction below 160m SSD is within the first 13m of the immediate approach to the downstream merge. See further commentary below.
Compliance with DMRB	Compliant	The reduction of SSD below desirable minimum is a departure , and included within reference G6G7 on the basis that CD 122 does not permit relaxations below desirable minimum on connector roads.	The reduction of SSD below desirable minimum is a departure , and included within reference G6G7 on the basis that CD 122 does not permit relaxations below desirable minimum on connector roads.

[5.145.15](#) It can be seen from the above that in options 2B/2D the desirable minimum SSD of 160m can be achieved to a 1.05m object which represents a vehicle on the road ahead. As the link will be under motorway regulations with a hard shoulder the likelihood of a low object on the road is reduced from an all-purpose road. As a mitigation measure a 50mph speed limit is proposed and the speed limit is shown on **Document DCO 2.14**.

[5.155.16](#) CD 109 does not permit relaxations on the immediate approaches to junctions. In the case of a merge designed to CD 122, the immediate approach is defined as a distance of 1.5 times the SSD measured from the back of the nose. i.e. from a point

240m before the back of the nose there cannot be a reduction below the desirable minimum SSD of 160m. This requirement is met in options 2A/2C, but in options 2B/2D due to the longer crest curve the first 13m approximately of the immediate approach has an SSD below 160m measured to the low object height. However, as the merge is a lane gain there is a reduced potential for incidents at the merge. This is covered as part of departure reference **G7**.

Cross-section (Connector Road – Interchange Link)

5.165.17 In accordance with CD 127, para 2.1, Figure 2.1.1N1b provides the required cross-sectional dimensions for a rural motorway connector road.

~~5.17 Based on predicted vehicle per hour traffic flows for the The interchange link highlighted above, and in accordance with CD 122 para 5.17 and Table 5.17b, the minimum connector road type is IL1A.~~

~~5.18 As discussed in section 4 above the, based on the upstream diverge layout affects being Option C+, is 940m long between the lengthback of the interchange link. For the selected diverge option C+ the interchange link is less than 1km nose and the back of the merge nose and the link would be subject to motorway regulations.~~

~~5.19 Based on the predicted flows and using CD 122 table 5.17b a two lane interchange link of cross-section IL2A is required.~~

~~5.20 As set out above for Option C+ for the J24A diverge a single lane layout A option 2 diverge is proposed and hence this forms an upstream constraint. As set below the merge onto the A50 westbound is a single lane gain layout D merge and this forms a downstream constraint. With these constraints in place there is limited value on providing a two lane interchange link as it would only provide for a relatively short length of two lanes.~~

~~5.21 Capacity analysis shows that a single lane interchange link is considered to have more capacity than the 1,350vph threshold given in CD 122 table 5.17b, and depending on the analysis used could have capacity for over 2,000 vph.~~

~~5.22 CD 122 para 5.3 does not permit single lane interchange links longer than 1km. It is assumed the reason for this being the potential for driver frustration in not being able to overtake a slower moving vehicle. The length of the proposed interchange link is 940m so this threshold is not met. Furthermore, the link is from a motorway (and will therefore not have very slow moving vehicles) and a 50mph speed limit is proposed (see safety risk treatments below) which will reduce the differential in speeds between HGVs and light vehicles.~~

~~5.23 In summary, a single lane interchange link is proposed to cross section IL1A which does not comply with CD 122 para 5.17 and table 5.17b and is therefore **departure** from standard, reference **G14**.~~

Lane width

5.195.24 The lane width is 3.7m as required by CD 127. The horizontal alignment of the interchange link does not have a radius of less than 400m and hence no lane widening is required.

Hard shoulder, hard strip and verge

5.205.25 The following are provided in accordance with CD 127 for cross-section IL1A:

- ~~1.5m (min) nearside verge~~
- 3.0m nearside verge (wider than the 1.5m minimum required by CD 127 to provide sufficient space for VRS and other assets such as lighting columns and signs)
- 3.3m hard shoulder
- 0.7m offside hard strip
- ~~2.3m (min) 3.0m~~ offside verge (again wider than the minimum for the same reasons as the nearside verge)

Headroom

5.215.26 For the option 1B/1C underbridge the headroom on the interchange link would be a minimum of 5.3m plus compensation for the sag curve.

5.225.27 For the overbridge options, the A453 northbound between M1 J23A and M1 J24, and then onto the A50, is part of High Load Route (HiR) 13a between Wansford (R26 A1/A47) to Stoke on Trent (A50/A520). This is an 18' route with other structures on the route having a minimum headroom of the following:

- A42 Doctors Lane bridge: 6.05m;
- A50 B5460 interchange bridge: 5.81m;
- A6 Shardlow Road bridge: 19' (5.79m); and
- A5111 Harvey Rd bridge: 5.66m.

5.235.28 The proposed bridge location in the context of HiR13a is shown on **Figure 5.1** below.

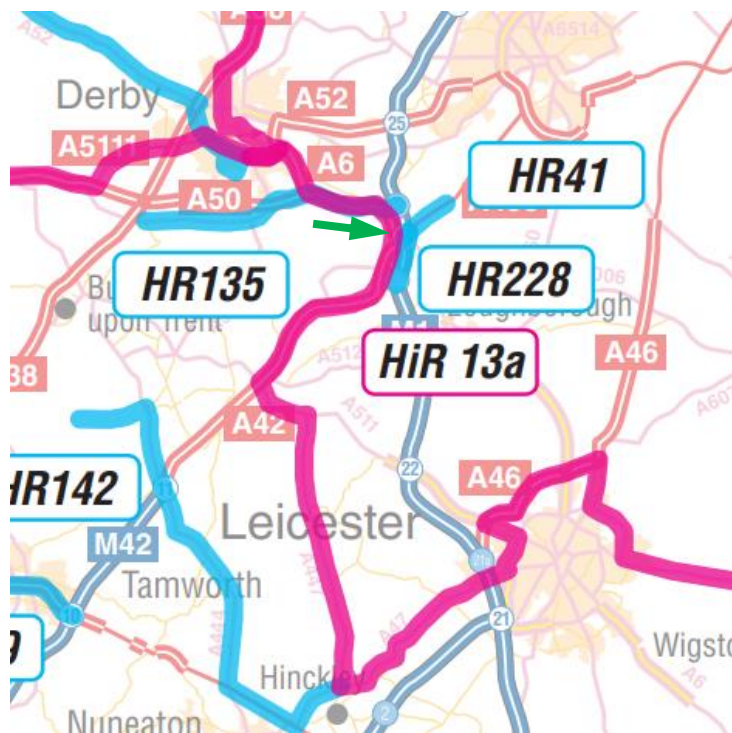

Figure 5.1 High load routes and location of proposed bridge

[5.245.29](#) Options 2A & 2C provide compliant headroom of 6.45m for a high load route, in accordance with CD 127 table 4.1. High load routes are recorded by the DfT as being either 18' or 20' routes but CD 127 does not distinguish between the types of routes. As the A453 northbound is an 18' route, it is reasonable that the clearance is reduced by 2' i.e. 0.61m to 5.84m and this is the headroom proposed in Options 2B & 2D but this requires a **departure** from standard reference **G8**. As noted above the reduction in headroom allows a greater crest curve value to be provided. The reduction in headroom is not considered to have any safety implications given it would be over 0.5m higher than the standard 5.3m headroom.

Safety risk assessment, summary and preferred option

[5.255.30](#) As discussed above Option 1B/1C requires a surface water pumping station which introduces risks to users and maintenance workers. These risks are significant as set out in the safety risk assessment found at **Appendix 23**. They can be eliminated by the overbridge options.

[5.265.31](#) Given the headroom on other structures on the 18' high load route governs the abnormal loads that can be used, it is reasonable that the clearance is reduced by 2' i.e. 0.61m to 5.84m.

[5.275.32](#) In terms of the vertical crest curve although there is a short distance where the minimum SSD to a 0.26m object falls below 160m on the immediate approach to the merge, the overall SSD along the interchange link in option 2D is better than option 2B.

[5.285.33](#) It can be seen in the safety risk assessment that option 2D has the lowest overall risk and on this basis it is recommended that **Option 2D** be taken forward. This is shown on the following **Documents**:

- **DCO 2.8C:** General arrangement
- **DCO 2.9C:** Cross-sections
- **DCO 2.10A:** Profile (long-section)
- **DCO 2.11:** A453 bridge plan

Departures From Standard

[5.295.34](#) **Appendix 34** provides a summary of the road layout departures from standard within this section based on option 2D and provides their current approval status.

6. A50 WESTBOUND MERGE

Layout

6.1 With the proposal to introduce a separate interchange link between the M1 and A50 (see above) a new merge onto the A50 westbound is required downstream of the junction 24 roundabout.

6.2 The following table sets out the 2038 design year traffic data for the ~~diverge using the 2A model data~~ A50 westbound merge with the interchange link from the M1 northbound:

Location	AM Peak		PM Peak	
	Vehicles	HGVs% <u>HGV</u>	Vehicles	HGVs% <u>HGV</u>
A50 WB upstream of merge (exit from J24 roundabout)	16331503	25910.3	11591227	1739.6
Merge from M1 NB A50 WB downstream of merge	28961752	4482.1	24811467*	3718.8
A50 WB downstream of merge Merge from M1 NB	12633255	189	13222694**	198

* Forecast flow as discussed above. The following table sets out demand flow is 1766 vehicles in the 2038 design year traffic data for PM peak hour.

6.3 ** Using 1467 forecast flow from the ~~diverge using~~ M1 NB; if the ~~2B model data~~ demand flow is assessed then increases to 2993

Location	AM Peak		PM Peak	
	Vehicles	HGVs	Vehicles	HGVs
A50 WB upstream of merge	1486	195	1018	157
A50 WB downstream of merge	2831	398	2336	363
Merge from M1 NB	1345	203	1318	206

6.4.3 Based on CD 122, para 3.9, an adjustment factor of 1.01 is used in the above for the mainline flows and 1.06 for the merge flows due to the percentage volume of HGVs is not required.

6.5.4 Using the traffic data above, and in accordance with CD 122, Figure 3.12a, the data has been plotted on ~~Figure 6.1~~ Figure 6.1 below and based on this a 'layout ~~DE~~ lane-gain gain with ghost island' merge is required.

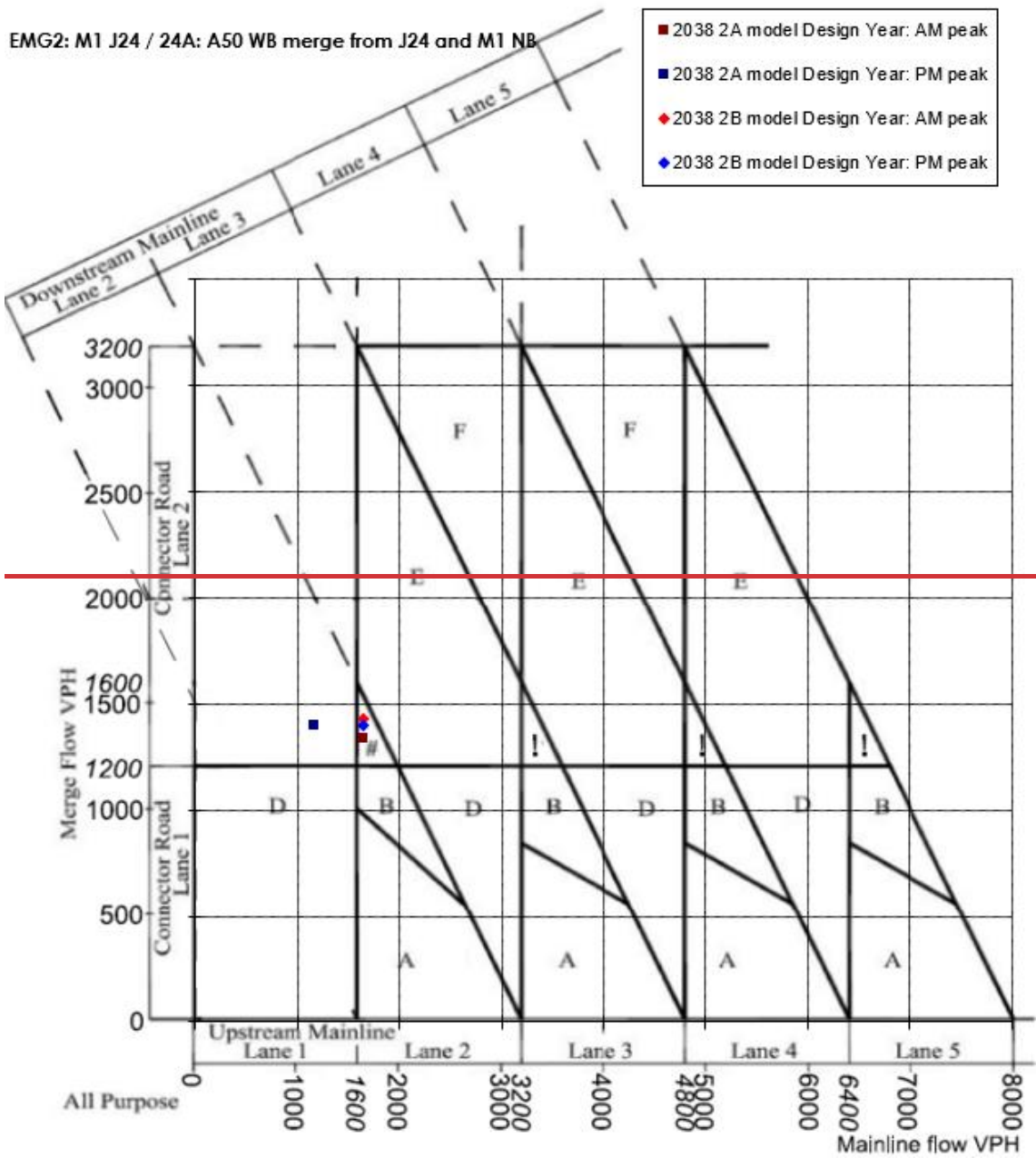

6.5 A layout E merge would be longer than the layout D merge, due to the need for a 130m taper and 150m ghost island tail (based on rural design speed of 85kph), adding 280m in length. Furthermore a layout E merge has a greater cross-section with space for the taper (on lane 2), lane gain (lane 1) and ghost island. Use of a Layout E merge would not by itself remove the need to address the issue that the interchange link has to be reduced to two lanes before the downstream M1 SB IL merge and a lane reduction taper would still be required and this would be likely to need to move downstream by the same 280m distance.

6.6 A layout E merge would by its nature require vehicles in lane 2 to merge into lane 1 of the M1 J24 to A50 WB interchange link, this merge is located at a point where the M1 J24 to A50 WB interchange link has a horizontal radius of 360m (the desirable minimum of 510m being required) and a reduced SSD of 135m. With additional traffic then using

the middle lane (of the three lane section) this would increase the flows in lanes 2 and 3 before the offside lane reduction taper.

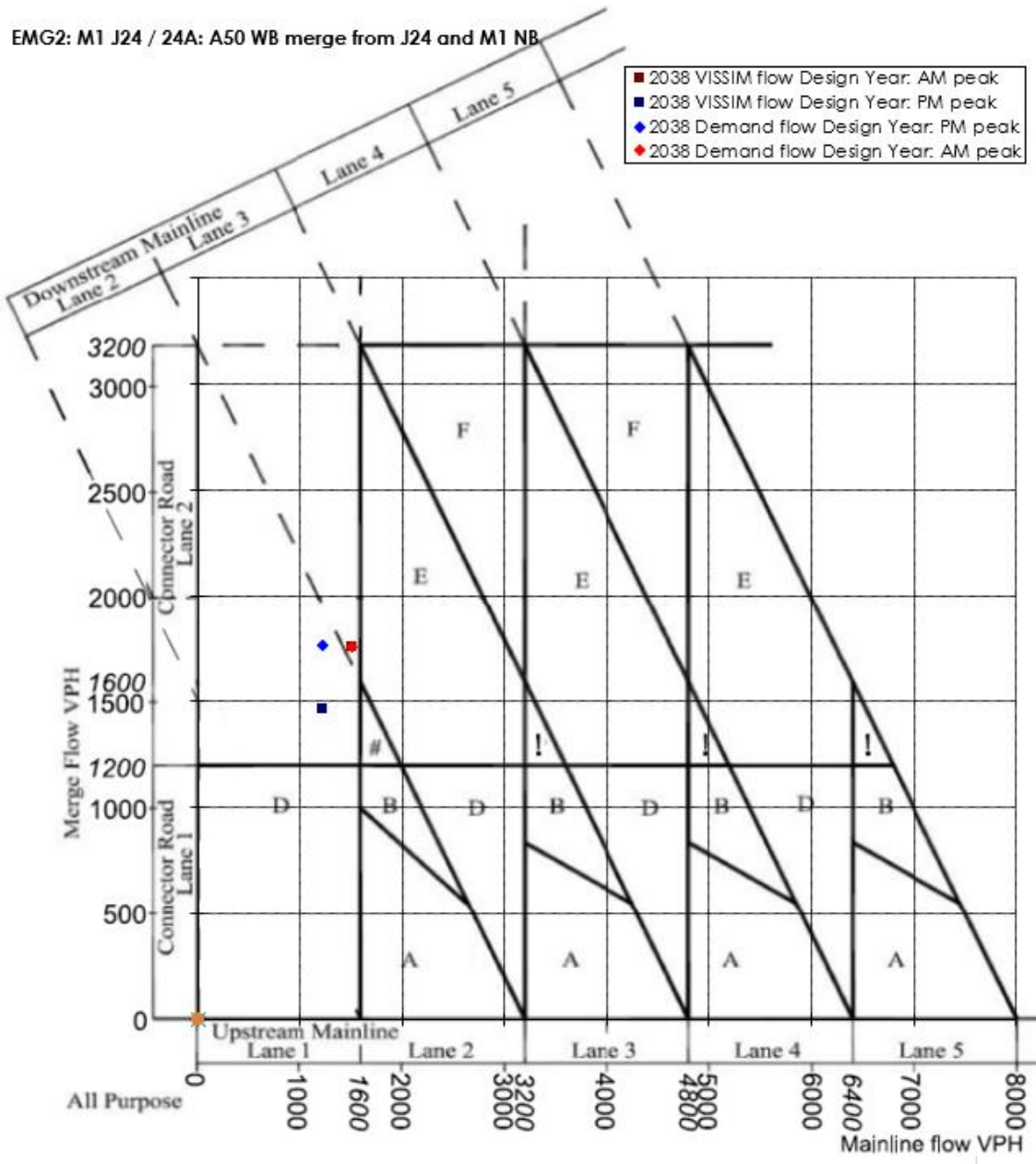

Figure 6.1 A50 westbound merge layout requirement using traffic data

6.6 The provision of the new link will divert traffic away from both the M1 J24 roundabout Overall and the A453 to A50 SLTL and given that as can be seen from the dataset out above the traffic flows are relatively well balanced.

6.7 With M1 NB to A50 WB interchange link is forecast to operate within capacity as a single lane, maintaining this in mind it is proposed that the most appropriate as a single lane gain layout for the new D merge would be to have is considered to provide the best overall layout with a lane gain from 2 to 3 lanes. However, the This is departure reference G9.

[6.7.6.8](#) The downstream interchange link is two lanes which then merges into the A50 westbound around 1.5km downstream of the new merge. A lane ~~drop~~reduction on the interchange link is therefore required prior to the downstream merge and the most appropriate layout is therefore considered to be a form of a layout G option 2 merge with a reduction taper to two lanes prior to the downstream merge. Further information on this is set out below.

[6.8.6.9](#) The new merge would be located downstream of the roundabout exit and downstream of the end of the segregated left-turn lane (SLTL) which forms a lane-gain from the A453. In addition to the SLTL there is a lane drop on the exit from the M1 junction 24 roundabout (which is a lane reduction to roundabout standards).

[6.9.6.10](#) The introduction of the additional M1 northbound merge would mean there would be several merges within close proximity to each other. As it is not possiblefeasible to reduce the A50 westbound exit from the J24 roundabout to a single lane prior to the proposed merge, the layout of the western side of the junction 24 signalised roundabout is to be amended such that a two lanes exit from the roundabout with the SLTL removed. This removes the two existing conflict points. The roundabout geometry is assessed in more detail within section 10.

[6.10.6.11](#) The overall alignment of the existing and proposed A50 westbound interchange link is shown schematically on **drawing EMG2-BWB-GEN-XX-SK-CH-SK046**.

Design Speed and Geometry

[6.11.6.12](#) As discussed above the M1 northbound to A50 westbound interchange link has a design speed of 85kph.

[6.12.6.13](#) The A50 westbound from M1 junction 24 roundabout is itself classified as an interchange link, forming a long slip road from the roundabout to the merge onto the A50 westbound (joining with the interchange link from the M1 southbound to A50 westbound). Therefore in accordance with CD 122 para 5.4 and Table 5.4 this interchange link also has a design speed of 85kph.

[6.13.6.14](#) The layout of the merge is shown on **Document DCO 2.8C** and **drawings EMG2-BWB-HGN-A50WB-DR-H-0101 and 0102**. The required geometry stated is in accordance with CD 122 para 3.21 and Table 3.21.

- A near straight of radius 720m over a minimum of 75m is provided on the M1 northbound to A50 westbound interchange link prior to the merge;
- The nose length is 75m (based on rural all-purpose design speed of 100kph or less);
- The M1 J24 to A50 westbound interchange link has a right-hand curve with horizontal radius of 340m at the point of the merge, which is just below one step below desirable minimum for 85kph but as CD 122 does not permit relaxations below desirable minimum (in this case 510m) on connector roads this is an **existing departure** (DAS ID 72229);
- The M1 J24 to A50 westbound interchange link then has a transition into a straight and then another transition into a left-hand curve again of 360m radius which for the reasons stated above is an **existing departure**; and

- At a point 290m downstream of the lane-gain merge it is then proposed to provide a lane-drop, reducing from three lanes to two, prior to the merge onto the A50 westbound mainline. Further information is set out below.

Lane reduction before the A50 westbound mainline merge

6.146.15 Downstream of the above, the interchange link from the J24 roundabout merges with the interchange link from the M1 southbound. CD 122 para 3.13 states that for three lane merges a layout G or H merge shall be used. The existing merge has two-lanes from the merge, and the traffic flows do not require three lanes and therefore layout G option 2 can be used.

6.156.16 CD 122 merge layout G option 2 requires a lane reduction with an associated taper. As stated at CD 122 para 3.19 Note, the reduction taper followed by a merge are successive merges and the requirements for successive merges and diverges applies. This is dealt with at CD 122 para 3.36 and the minimum spacing of successive merges is $3.75Vm$, with V in this case being 85kph giving a minimum of 319m. This is measured between the end of the reduction taper and the tip of the downstream nose, as per figure 3.14j.

6.166.17 CD 122 provides design requirements for lane reduction tapers on connector roads and at para 3.19 cross references table 7-4 chapter 5 of the traffic signs manual. This table gives preferred and absolute minimum tapers based on the 85th %ile of vehicles. Between an 85th %ile speed of 40 and 50mph a 1:45 taper is recommended, and between 50 and 60mph a 1:50 taper is recommended.

6.176.18 The actual proposed distance between the successive merges is 1km. This being the case it is not proposed to provide effectively three lanes width of carriageway between the reduction taper and back of nose, with the offside lane hatched out. Instead it is only proposed to provide two lanes after the reduction taper.

6.186.19 It is however considered appropriate to allow for merge overrun. This layout may be considered to be an aspect not covered by standards and would be assessed as part of departure reference **G9**.

6.196.20 It is only CD 109 that provides a standard for a lane drop within a link, which is for ending climbing lanes and is shown on Figure 8.7N. This shows, irrespective of design speed, a 1:45 taper followed by an overrun area which then tapers at 1:45. The overall length, assuming 3.65m lanes, is $2 \times 165m = 330m$.

6.206.21 CD 127 does, however, state at table 2.28 that for an 85kph design speed mainline lanes should transition at 1:45.

6.216.22 As both standards use the value of 1:45 it is proposed that the transition in number of lanes on the interchange link is as follows:

- Merge taper of 1:45 for a distance of 165m to remove the third lane, but with full paved width provided to allow for merge overrun; and
- Paved width (hatched out) to then taper at 1:45 for a distance of 165m.

Stopping Sight Distance / Visibility

[6.226.23](#) For an interchange link of design speed 85kph the desirable minimum SSD is 160m in accordance with CD 109 table 2.10.

[6.236.24](#) There is an existing relaxation below desirable minimum to 135m SSD on the M1 J24 to A50 westbound interchange link on the right-hand bend downstream of the SLTL. This is an **existing departure** (DAS ID 72229).

[6.246.25](#) This reduction in SSD will take place on the immediate approach to the proposed merge and therefore requires a further **departure**, reference **G10** as the existing layout would change with the new merge being in place. The changes to the layout of the exit from the J24 signalised roundabout will improve the SSD but it will still fall below 160m.

[6.256.26](#) The SSD prior to the lane drop on the interchange link is at or greater than desirable minimum SSD of 160m. The minimum SSD of 160m is achieved over the immediate approach of 240m prior to the start of the lane reduction taper.

Speed limit

[6.266.27](#) The existing speed limit changes from 50mph to national speed limit at the end of the initial right hand bend when leaving the J24 roundabout. The scheme proposes to relocate this change in speed limit to the end of the lane drop / reduction. The change in speed limit is shown on **Document DCO 2.14**.

Departures From Standard

[6.276.28](#) **Appendix 34** provides a summary of the road layout departures from standard within this section and provides their current approval status.

7. M1 SOUTHBOUND / A50 EASTBOUND TO M1 JCT 24 INTERCHANGE LINKS

Layout

- 7.1 The SRN works propose to increase the number of lanes from one lane to two lanes through the interchange link between the A50 eastbound and merge with the M1 Jct 24 southbound diverge interchange connector road, and then to three lanes from the merge for the approach to the roundabout junction at M1 J24.
- 7.2 The links affected by these proposals are as follows –
- A50 eastbound to M1 J24 interchange link connector road; and
 - M1 Southbound to M1 J24 interchange link connector road.
- 7.3 The layout is shown on **Document DCO 2.8C** and **drawings EMG2-BWB-HGN-A50EB-DR-H-0101 and 0102**.

Traffic Flows

- 7.4 The following table sets out the 2038 design year traffic data for the ~~diverge for the 2A model data~~ interchange links:

Location	AM Peak		PM Peak	
	Vehicles	HGVs% <u>HGV</u>	Vehicles	HGVs% <u>HGV</u>
A50 eastbound to M1 Jct 24 interchange link	1603 <u>1601</u>	2409.0 <u>2409.0</u>	1541 <u>1631</u>	231 <u>5.6</u>
A50 eastbound to M1 southbound	1392 <u>2899</u>	209 <u>10.7</u>	534 <u>853</u>	83 <u>11.6%</u>
M1 southbound to M1 Jct 24 interchange link	1114 <u>246</u>	1677.4 <u>1677.4</u>	981 <u>552</u>	1472.4 <u>1472.4</u>

- 7.5 ~~The following table sets out the 2038 design year traffic data for the diverge for the 2B model data:~~

Location	AM Peak		PM Peak	
	Vehicles	HGVs	Vehicles	HGVs
A50 eastbound to M1 Jct 24 interchange link	1576	236	1504	225
A50 eastbound to M1 southbound	1365	205	545	81
M1 southbound to M1 Jct 24 interchange link	1011	152	954	142

Design Speed and Geometry

[7.67.5](#) All the connector roads for this section of the proposals for the purpose of design criteria have been considered as interchange links. Therefore, the design speed in accordance with CD 122, para 5.4 and Table 5.4 for a rural mainline design speed of 120kph is 85kph.

A50 eastbound interchange link connector road

[7.77.6](#) The proposal is to increase the number of lanes for the A50 interchange link from one to two lanes immediately after the fork diverge for the M1 southbound at M1 J24A. The rate of change of 1:45 is in accordance with CD 127, para 2.28, and Table 2.28.

[7.87.7](#) Through the length of the merge a horizontal curve of 1440m and transition (both compliant with CD 109) ahead of tying into the existing channel geometry are provided.

[7.97.8](#) The centreline of the lane gain continues along the existing channel line until it ties into the existing centreline of the third approaching the roundabout. The geometry of this centreline provides a compliant design to CD 109 with 510m (5% superelevation) and 1440m radius left hand curves with suitable transition between curves.

[7.107.9](#) The vertical alignment follows the existing alignment and the crest and sag K values are at or better than the desirable minimum. **Document DCO 2.10B** shows the vertical alignment.

M1 southbound diverge connector road

[7.117.10](#) The existing horizontal alignment of the connector road at the location of the merge with the A50 eastbound connector road has a 510m righthand curve. The proposals provide a tighter 360m curve to enable the lane gain introducing a one step below desirable minimum relaxation from standard with a 7% superelevation. The curve is followed by a horizontal transition with a length of 60.271m in accordance with CD 109 para 4.13 albeit with a **relaxation** in the rate of increase of centripetal acceleration of 0.6m/sec³ in accordance with CD 109 para 4.14 & 4.14.1.

[7.127.11](#) No changes to the existing vertical alignment are proposed.

A50 eastbound and M1 southbound Jct 24 interchange links merge

[7.137.12](#) For the purposes of designing the geometry for this merge, the A50 2 lane interchange link is considered as the mainline with the M1 southbound diverge connector being the merge.

[7.147.13](#) Although CD122 para 3.1 states that offside merges and diverges shall not be provided at full grade separated junctions, the merge above is within two interchange link connector roads and therefore is not considered to be at a full grade separated junction.

[7.157.14](#) The predicted traffic figures suggest a Layout D, 'lane gain' merge is required in accordance with CD122, para. 3.12, Figure 3.12a and 3.14e.

[7.167.15](#) The geometry of the merge is shown on drawings EMG2-BWB-HGN-A50EB-DR-H-0101. The required geometry stated is in accordance with CD 122, para 3.12, and Table 3.21 for a rural all-purpose connector road design speed.

- The nose ratio is 1:12 for 75m and matches the existing layout. Although the length of the nose is in accordance with the design standards, the nose ratio is greater than the required 1:25 which is a **relaxation** permitted under CD 122 para 3.21 Note 1.
- The maximum width of the hatch marking forming the nose is 6.25m and therefore within the 8m maximum width.

A50 eastbound and M1 southbound Jct 24 approach

[7.177.16](#) Immediately after the A50 eastbound and M1 southbound Jct 24 interchange link merge the carriageway continues as 3 lanes and ties in with the existing 3 lane approach to M1 J24 roundabout junction.

Stopping Sight Distance / Visibility

A50 eastbound & M1 southbound diverge connector roads

[7.187.17](#) As stated within CD 122, para 3.23, connector road SSD shall be provided along the length of the connector road up to the back of the nosing.

[7.197.18](#) CD109, Table 2.10, states that the desirable SSD for an 85kph design speed is 160m.

[7.207.19](#) The A50 eastbound connector road achieves minimum SSD from the diverge with the M1 southbound at J24A to the M1 southbound merge with no obstructions to visibility for the length of the merge nose. The same is true for the M1 southbound diverge connector road.

A50 eastbound and M1 southbound Jct 24 approach

[7.217.20](#) Forward visibility on the approach to the M1 J24 roundabout provides SSD as required by CD 116 paras 3.43 and 3.46 and to the chevron traffic signs to CD 116 para 3.47.

[7.227.21](#) As the proposals tie into the existing 3 lane approach ahead of the junction other signalised roundabout visibility criteria has not been considered.

Weaving

[7.237.22](#) There is an existing weaving section from the merge between the A50 eastbound and M1 southbound to the traffic signal stop line at the M1 J24 signalised roundabout. This weaving length is an **existing departure** (DAS ID 7222).

[7.247.23](#) As the downstream end of the link is a signalised stop line the standard weaving calculation for the number of lanes is not applicable. However, traffic modelling has

shown that the existing two-lane section does not provide sufficient capacity and a third lane is proposed over the weaving length.

Cross Section

[7.257.24](#) The cross-sections are shown on **Document DCO 2.9C**.

Lane widths

[7.267.25](#) Based on predicted vehicle per hour traffic flows for the interchange links highlighted above, and in accordance with CD 122, para 5.17, and Table 5.17a, the connector roads type is IL2C. However, an additional lane is provided due to the weaving section (see above).

[7.277.26](#) CD 127 para 2.1 and Figure 2.1.1N1f states for a rural all-purpose connector road, as well as having a horizontal curvature of greater than 400 metres radius (CD 127 para 2.2 and CD122.5.18), the lanes widths shall be 3.65m wide.

Hard Shoulders / Hard Strips / Verges

[7.287.27](#) Connector road type IL2C states that a 1.0m hard strip and 2.5m verge shall be provided on both the nearside and offside of the carriageway.

[7.297.28](#) For the A50 eastbound connector prior to the merge with the M1 southbound diverge connector, the offside of the carriageway maintains the existing hard strip and verge while a 1.0m hard strip with 2.5m verge is proposed on the nearside of the carriageway replacing the hard shoulder.

[7.307.29](#) At the above merge the offside channel provides a 1.0m hard strip and 2.5m verge for the extent of the merge and on approach to Jct 24 roundabout until the channel tie-in to the existing. At this point the hard strip tapers to nothing at a rate of 1:45 in accordance with CD 127 para 2.28 and Table 2.28.

8. A453 SHARED USE CYCLE/FOOTWAY

Layout

- 8.1 The SRN works propose a shared unsegregated cycle/footway ('shared facility') is proposed along the A453 between the existing A453 / A6 Kegworth Bypass / EMG1 (Wilders Way) and the EMG2 development.
- 8.2 The shared facility will connect to the existing shared unsegregated cycle/footway facility at the northern end (that connects to EMG1, Kegworth village and along the A6 Kegworth Bypass) and into the proposed EMG2 development to the south via a new southern arm off the existing A453 / Beverley Road (EMA access) roundabout.
- 8.3 This report provides design information for the section from the northern tie-in point to the extent of the National Highways boundary some 520m south, adjacent to the A453.
- 8.4 The layout of the shared use footway/cycleway is shown on **Document DCO 2.8B** and **drawings EMG2-BWB-HGN-A453-DR-H-0103 & 0104**.

Traffic Flows

- 8.5 Based on the existing usage of the cycle networks in the vicinity of EMG1 and the proposed EMG2 site the envisaged usage is predicted to be well below 200 users per hour.

Design Speed and Geometry

- 8.6 The design of the shared facility has been based on CD 143 England National Application Annex. However, this design standard does not provide geometric parameters and criteria for the design for shared facilities. As the design requirements are more onerous for cyclists than pedestrians, CD 195 has been used where appropriate to establish the design requirements. However, this is not a mandatory standard for shared use facilities.
- 8.7 The design speed for the shared facility is 30kph in accordance with CD 143 Para. E/3.1 and Table E/3.1.
- 8.8 A desirable minimum width of 3.0m is proposed for the shared facility (CD 143, Para. E/3.5) with 1.0m verge either side and a minimum offset to the carriageway of greater than 1.5m (CD 143, Para. E/3.5.1).
- 8.9 The crossfall of the shared facility is 2.5% in accordance with CD 143 Para. E/3.3 and 'Inclusive Mobility, Para. 3.2.
- 8.10 Proposed horizontal curves on the shared facility generally exceed the minimum criteria of 32m radius as stated within CD 195, Para. E/3.20 and Table E/3.20. The exception to this is at the northern tie-in where there is a proposed reverse curve with radii of 11.5m to avoid significant earthworks and to tie into the existing facility perpendicularly.

However, Whilst this constitutes a departure ~~reference G11~~ from CD 195, as noted above CD 195 is not a mandatory standard.

- 8.11 Proposed vertical curves on the shared facility are at or greater than the minimum criteria of $k=5$ for sag curves and $k=6$ for crest curves.
- 8.12 The vertical alignment of the shared use footway/cycleway is shown on **Document DCO 2.10C** and cross-sections are shown on **Document DCO 2.9B**.

Visibility

- 8.13 Junction visibility at the northern tie-in has been achieved based on the 4.5m set-back (x-distance) and the 31m sight line (y-distance) in accordance with CD195, Para. E/3.5 and Table E/3.5, Table E/3.6 and Table E/3.18. Noting however that the visibility criteria refers to cyclists needing to stop and give way which is not specifically required on a shared facility.

Departures From Standard

- ~~8.14 **Appendix 3** provides a summary of the departures from standard within this section.~~

9. A453 / A6 / EMG1 ACCESS JUNCTION

Layout

- 9.1 The proposed works at the existing A453 / A6 Kegworth Bypass / Wilders Way (EMG1 access) junction is to introduce an additional right turn lane on the eastern side of the signalised gyratory.
- 9.2 A new controlled pedestrian crossing is proposed at the Wilders Way eastbound junction approach with the A453. The crossing is to provide access between the proposed drop-off lay-by facility on Wilders Way and the EMG1 bus interchange. This is associated with the EMG1 Works.
- 9.3 **Documents DCO 2.8B, MCO 2.8 and Drawing EMG2-BWB-HGN-EMG1-DR-H-0101** show the proposed layout.

Traffic Flows

- 9.4 Traffic modelling has shown that there is a requirement to provide two right turning lanes from the A453 southbound to the EMG1 access. The overall junction capacity is reviewed in the transport assessment.

Design Speed and Geometry

- 9.5 The existing signed speed limit is 50mph. The proposals are minor changes to an existing rural traffic signalised junction and do not affect the approaches.

A453 Southbound and Wilders Way Westbound Signalised Junction Arm

- 9.6 The additional right turn lane proposes a lane width of ~~4.65m~~8m with the ~~second~~ existing lane widened to 4.5m albeit the existing single lane approach ~~includes~~included an area of hatched markings to allow additional spaces for large turning vehicles as required by CD 123, para. 7.13. Therefore, both lanes exceed the minimum 3.0m wide lanes required by CD 123, para. 7.9. ~~Drawing EMG2-BWB-GEN-XX-SK-CH-SK038~~HGN-EMG1-DR-H-0102 shows the vehicle tracking for the design vehicle. The kerblines radii have been amended to facilitate this.
- 9.7 With the existing design speed of 85kph retained, the right turning traffic continues to be maintained by separate signals to the straight-ahead traffic with a traffic island as required by CD123, para. 7.18.

- ~~9.8 The realigned nearside kerblines reduces the existing kerblines radii to 15m and 70m. These radii accommodate the design vehicle swept paths.~~

A453 Northbound and EMG1 Wilders Way Eastbound Signalised Junction Arm

- ~~9.9.8~~ The purpose of amending the EMG1 Wilders Way approach is to provide a signalised crossing. This will connect a new drop-off lay-by in the EMG1 development to the existing bus interchange. This in turn requires amendments to the left-turn from Wilders

Way onto the A453 northbound to increase the size of the splitter island to accommodate the pedestrian crossing.

[9.109.9](#) The proposals widen the existing eastbound EMG1 Wilders Way left turn lanes for A453 northbound to 4.7m each to improve the swept paths of the design vehicle (CD 123, para 7.13). The widths therefore are greater than the minimum required by CD 123, para. 7.9. **Drawing EMG2-BWB-~~GEN-XX-SK-CH-SK038~~HGN-EMG1-DR-H-0102** shows the vehicle tracking for the design vehicle.

[9.119.10](#) A 3.0m wide crossing is proposed at both crossing points, with a 3.0m distance between the existing stop line and crossing studs. The footway either side is proposed at 3.0m at the crossing tapering down to a 2.0m footway. A minimum of 1.5m separation between the carriageway and footway is provided.

[9.129.11](#) Additionally, the traffic island is proposed to be altered to provide a minimum 1.5m set-back from the A453 through lanes at the junction in accordance with CD123, para. 7.15.

Visibility

A453 Southbound and Wilders Way Westbound Signalised Junction Arm

[9.139.12](#) In accordance with CD 123, para. 7.2, each traffic lane has clear visibility of at least one primary signal at desirable SSD from the A453 southbound.

[9.149.13](#) A minimum of 2 signal heads can be seen from the approach arm and stop line.

[9.159.14](#) Junction Intervisibility remains unaltered by the proposals and complies with CD 123, para 7.4.

A453 Northbound and Wilders Way Eastbound Signalised Junction Arm

[9.169.15](#) In accordance with CD 123, para. 7.2, each traffic lane has clear visibility of at least one primary signal at desirable SSD on the approach to the junction.

[9.179.16](#) A minimum of 2 signal heads can be seen from the approach arm and stop line.

[9.189.17](#) Junction Intervisibility remains unaltered by the introduction of the crossing and complies with CD 123, para 7.4.

10. OTHER WORKS ON THE SRN

M1 J24 signalised roundabout traffic signing and road marking alterations

10.1 The works on the SRN include for works to the J24 signalised roundabout to reassign lanes to maximise capacity. The works are as follows:

- Traffic from the A453 southbound approach seeking the A453 southbound to EMG1, EMG2 and EMA will be signed to use lanes two and three at the A453 southbound signal stop line as opposed to lane three at present; and
- Traffic from the A453 northbound approach seeking the M1 northbound will be signed to use lanes one and two at the A453 northbound signal stop line as opposed to just lane one at present.

10.2 The works require minor alterations to lining and signing and as no significant alterations to the geometrical layout are required they are not considered further in this report. The preliminary design is provided with the directional signage strategy found at **Appendix 28** of the Transport Assessment (**Document DCO 6.6A**).

10.3 Following the Stage 1 Road Safety Audit the directional signage strategy has been amended to provide further details on the updates to the existing lane destination markings and directional signage.

M1 J24 signalised roundabout west side

~~10.3~~10.4 As well as the changes to lane allocations from A453 northbound to M1 northbound discussed above, two further changes are proposed to the west side of the J24 signalised roundabout:

- Removal of the A453 northbound to A50 westbound and providing two lanes from the exit onto the A50, without a merge/lane-drop, as discussed at section 6 above; and
- Widening the inside of the J24 signalised roundabout to provide an additional lane, to then allow three lanes to be provided from the M1 northbound to A453 northbound through the junction.

~~10.4~~10.5 These works comply with CD 116 save for the M1 Northbound J24 exit slip road approach entry deflection onto the roundabout which exceeds 100m and is **departure** reference **G12**. The approach will be under fill time signal control which will reduce the risks associated with excess entry deflection.

Finger Farm directional signage

~~10.5~~10.6 The works at Finger Farm relate solely to directional signage and are therefore not considered further in this report. The preliminary design is provided with the directional signage strategy found at **Appendix 28** of the Transport Assessment (**Document DCO 6.6A**).

M1 northbound directional signage

~~10.6~~10.7 Signage works are proposed to the M1 northbound on the approach to M1 J23A to direct users seeking the A50 to Stoke and Derby to use the new J24A exit rather than J23A as presently signed. The preliminary design is provided with the directional signage strategy found at **Appendix 28** of the Transport Assessment (**Document DCO 6.6A**).

11. PRINCIPLES OF GOOD ROAD DESIGN

- 11.1 An assessment of how the scheme design performs against DMRB standard GG 103, which provides principles of good road design, is found in Appendix 1 of the Design Approach Document, **Document DCO 5.3A**.

APPENDICES

APPENDIX 1: Safety Risk Assessment for M1 NB diverge and weaving length

Safety Risk Assessment: GG104	GG 104 version 0.1.0
Document reference	EMG2-BWB-GHS-XX-RA-CH-0001
Assessor	
Contact email	
Title of scheme	EMG2
BWB project number	220500
Part of scheme this applies to	M1 NB diverge layout at J24/24A
Location (map reference)	
Scope and purpose of this safety risk assessment	The purpose of this risk assessment is to assess the options for overall layout from J23A-J24/24A including the weaving length and diverge spacing
Safety objective	To manage the risk to affected parties as low as reasonably practicable.

Safety baseline: general comments	<p>PIC data: Circa 6 years of accident data has been obtained and this is for the period 1st January 2019 to 23rd October 2024 for the M1 northbound from J23A and to just beyond the J24 diverge.</p> <p>There is a cluster of PICs at the J24 northbound exit slip road and queuing back onto the M1 northbound mainline from the slip road is a regular occurrence at this location.</p>
Any recent changes in last 5 years that could affect safety?	None

Activity category	Type A
Features that need detailed review	2 Type B and 0 Type C

Principal hazard(s)	Weaving lengths are where drivers change lanes between a merge and a diverge and the amount of lane changing that takes place over the weaving length, along with the potential for late lane changing/swooping into the diverges, are the principal hazards.
Project description / background / objectives / outcomes	The purpose of the J24 improvements is to increase capacity to then facilitate EMG2. The main element of the works is to provide a free-flow link road from the M1 Northbound to A50 Westbound, taking this traffic out of the signalised roundabout (it is the only movement between the M1 and A50 that goes through the roundabout).

Populations affected	How is it affected and is there a specific safety objective?
Workers	Risks to workers shall be as low as reasonably practicable
Users	See principal hazard and objectives above
Other parties	No other parties are identified
Sub-populations - List	

Options / part of scheme to be assessed	Description of option / part of scheme
Option / Part 1	Existing situation - J24 layout B option 1 diverge with aux lane
Option / Part 2	Option A: J24A taper diverge followed by J24 taper diverge (Compliant diverge spacing)
Option / Part 3	Option C: J24A auxiliary lane diverge followed by J24 taper diverge
Option / Part 4	CD 122 compliant scheme (2km min weaving)
Option / Part 5	
Preferred option (if options are assessed)	Option / Part 3
How type B or C features (if any) affect option selection	Type B feature is because it does not comply with standards
State clear and precise reasons for selection	Overall the proposed options A and C, with mitigation measures, reduce the risks below the existing. Option C provides more length for drivers who may "swoop" and therefore becomes the preferred option overall.

Appraisal	
Are all risks for preferred option or parts as low as reasonably practicable following mitigation?	Yes
How have type B or C features (if any) been addressed?	Yes
Final recommendation for approval	
Recommendation	Option C should be progressed.
Any other comments / recommendations	The assessment shows that the risks in the proposed scheme following mitigation are lower than the existing scenario.

Date	19.02.26
Revision	P03
Status	S4

Safety baseline for M1 NB mainline for extents of scheme			
Years	2019-2024		
Slight	10		
Serious	3		
Fatal	0		
Map of PICs for last 5 years			

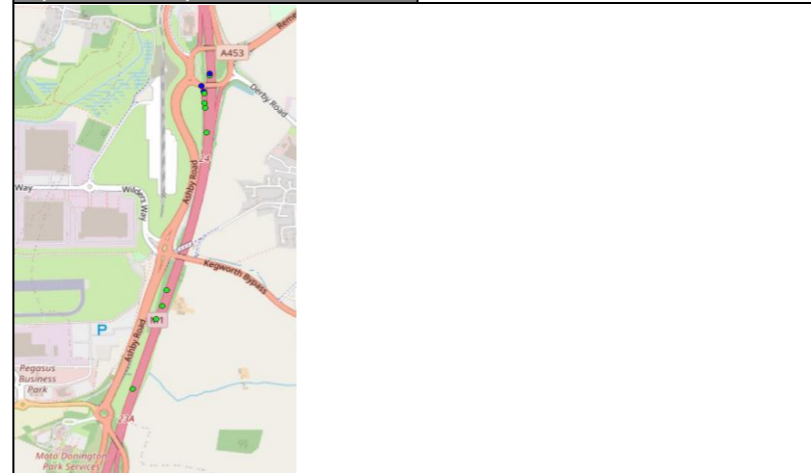

No. risks	Total risk score		Average risk score across all risks		No. risks eliminated
	Before mitigation	After mitigation	Before mitigation	After mitigation	
9	64	64	6.4	6.4	0
10	76	54	7.6	5.4	0
10	71	49	7.1	4.9	0
10	49	49	4.9	4.9	0
0	0	0			0

Feature (Table E/2.7)	Type	Indicator	Justification for choice of feature type	Select Type
Extent of prior experience of activity The degree of knowledge available from undertaking the activity previously or the degree to which knowledge is available from the activity being undertaken by other industries or organisations.	A	Activities for which there is significant experience within National Highways. Previous safety studies and data are available, and some activity features are codified in a standard or formal procedure.	Weaving and closely spaced diverges is a common feature	A
	B	Activities for which there is limited experience within National Highways but there is transferable experience elsewhere in the UK or internationally. Activities for which there is limited experience in National Highways but there is experience elsewhere in the UK or internationally, including in different industries, which is deemed sufficiently similar to the activity in question to be deemed relevant. Activities for which there is experience within National Highways but that experience is in a different application of the activity and some adaptation will be required. There might also be local and site specific issues to take into account that can affect the relevance of the available experience		
	C	Activities for which there is no previous applicable experience from either National Highways or other industries.		
Statutory and formal processes and procedures (including standards and legislation) Consideration of the applicability of current standards, formal processes or procedures, guidance and legislation.	A	The activity is substantially or entirely within the scope of existing standards, guidance, formal processes or procedures and applicable legislation. The activity requires minimal or no safety related departures from standard or safety related changes to formal processes or procedures (including any legislation).	Reduction in weaving and reduced spacing of diverges are departures	B
	B	The activity is largely within the scope of existing standards, guidance, formal processes or procedures. There can be some safety related departures from standards needed and/or safety related changes to formal processes or procedures. The activity can need minor changes to existing legislation.		
	C	Activities that are not within the scope of existing standards, formal processes or procedures and require new ones to be developed. Activities for which significant departures from standards, formal processes or procedures are required. Activities which require significant changes to existing legislation or new legislation to be written. Whilst the number of safety departures from standards, formal processes or procedures can affect the categorisation, the most important element in determining this is the nature and type of the departures. For example, a large number of safety departures that can be addressed straightforwardly will have less impact on feature type than a single safety departure that cannot and requires a detailed risk assessment to support it.		
Impact on the organisation The effect that the activity will have on current Highways England processes, procedures, structure, roles and responsibilities, competencies, policies and strategy, in addition to contractual and workforce arrangements.	A	The activity has no impact on National Highways. The activity has a minor impact on any of these for a finite period of time. Length of time National Highways is affected by decision to undertake the activity is short term.	No impact identified for National Highways	A
	B	The activity can lead to permanent minor changes to any of these. These minor changes can introduce new roles and responsibilities, policies, contractual and workforce arrangements. The activity can require a change to organisational arrangements. Length of time National Highways is affected by decision to undertake the activity is medium term.		
	C	The activity has significant impact on any of these. The activity can change core safety roles and responsibilities. Length of time National Highways is affected by decision to undertake the activity is long term.		
Activity scale Consideration of the size and/or scale of the activity. Does or can the activity have an impact on the motorway and all-purpose trunk roads, either directly or indirectly.	A	The impact of the activity is limited in nature or scale.	This covers a key section of the M1	B
	B	The impact of the activity is significant in nature or scale.		
	C	The impact of the activity is wide ranging across the network, and/or significantly impacts infrastructure, interventions or workforce.		
Technical Measure of technical and/or technological novelty and/or innovation the activity involves.	A	An activity where any processes, techniques, methodologies and/or technologies involved are currently in widespread use and re-examination is unlikely to be needed. There can be some experience of the processes, techniques, methodologies and/or technologies.	Such layouts are in widespread use and doesn't involve new technologies.	A
	B	The experience can be from use in either another application, or by another road authority, supplier, industry or perhaps from overseas in which case some additional work can be required to adapt them and/or to demonstrate that safety can be assured for the intended application.		
	C	Activities that use new processes, techniques, methodologies and/or technologies for which there is no previous experience in the UK or elsewhere.		
Stakeholder impact and interest The quantity and/or impact of stakeholders, their interest in and resulting ability to influence or/impact on the activity. The degree to which the safety issues, as perceived, are capable of being understood and fully addressed.	A	Activities for which the quantity and/or impact of stakeholders, their interest in and resulting ability to influence or impact the activity is low	Minimal impact to stakeholders.	A
	B	Activities that have only a single or a few stakeholders but their impact, in terms of their attitude towards, or ability to influence, and/or interest in the successful achievement of the activities aim can be significant. Alternatively it will represent an activity that has several stakeholders but the amount, or type, of safety issues involved are limited.		
	C	Activities for which there are a large number of stakeholders and their impact in terms of their attitude towards, or ability to influence can be significant. Stakeholders with a strong interest in the potential safety impact of the activity on themselves. Activities where there are conflicting needs arising from different stakeholders or stakeholder groups.		

Type A features 4
 Type B features 2
 Type C features 0

Table E/2.8.1 category type Type A
 No. other features to be reviewed in more detail 2 Type B and 0 Type C

Final category decision Type A

Safety Risk Assessment

Project Name	EMG2
BWB Project Number	220500
Design Element	M1 NB diverge layout at J24/24A

Unique Ref.	Phase	Hazard description (before mitigation)	Incident type	Hazard affects	Designer comments and assumptions
1	Operation	Frequent lane changing over short distances	Side swipes	Users	
2	Operation	Flow breakdown due to weaving and queuing on approach to first (A50) exit	Rear shunts or side swipes	Users	
3	Operation	Flow breakdown due to weaving and queuing on approach to first (A50) exit	High speed swerves with loss of control	Users	
4	Operation	J24 exit slip queuing back onto mainline	Rear shunts or multi vehicle incidents	Users	
5	Operation	Swooping into first exit (A50) following last moment lane changing	Side swipes	Users	
6	Operation	Swooping into first exit (A50) following last moment lane changing	Loss of control	Users	
7	Operation	Missed first exit (A50) and driver panics or attempts reverse	Multi vehicle incident	Users	
8	Operation	Driver enters first (A50) exit by mistake and changes lane back	Side swipes	Users	
9	Operation	Live lane breakdown	Collisions with stranded vehicle	Users	
10	Operation	Live lane breakdown	Collisions with pedestrian from stranded vehicle	Users	

Safety Risk Assessment

Project Name	EMG2
BWB Project Number	220500
Design Element	M1 NB diverge layout at J24/24A
Option / Part Reference	1
Option / Part Description	Existing situation - J24 layout B option 1 diverge with aux lane

Current design stage	Detailed Design
Notes	

Unique Ref.	Phase	Hazard description (before mitigation)	Incident type	Hazard affects	Is risk present in this option?	Risk without mitigation			Mitigation measures	Mitigation type	Risk with mitigation			Designer comments and assumptions
						Likelihood	Severity	Score			Likelihood	Severity	Score	
1	Operation	Frequent lane changing over short distances	Side swipes	Users	Yes	Likely: Once every 1-4 years	Moderate harm: Slight injury or illness, moderate damage or loss	8 : Low	Assessment of existing scenario hence no mitigation set out.		Likely: Once every 1-4 years	Moderate harm: Slight injury or illness, moderate damage or loss	8 : Low	
2	Operation	Flow breakdown due to weaving and queuing on approach to first (A50) exit	Rear shunts or side swipes	Users	Yes	Likely: Once every 1-4 years	Moderate harm: Slight injury or illness, moderate damage or loss	8 : Low	Assessment of existing scenario hence no mitigation set out.		Likely: Once every 1-4 years	Moderate harm: Slight injury or illness, moderate damage or loss	8 : Low	Existing layout has technology to detect queues and reduce speed limits
3	Operation	Flow breakdown due to weaving and queuing on approach to first (A50) exit	High speed swerves with loss of control	Users	Yes	Unlikely: Less than 1 per 10 years	Serious harm: Serious injury or illness, substantial damage or loss	6 : Low	Assessment of existing scenario hence no mitigation set out.		Unlikely: Less than 1 per 10 years	Serious harm: Serious injury or illness, substantial damage or loss	6 : Low	Existing layout has technology to detect queues and reduce speed limits
4	Operation	J24 exit slip queuing back onto mainline	Rear shunts or multi vehicle incidents	Users	Yes	May happen: Once every 5-10 years	Serious harm: Serious injury or illness, substantial damage or loss	9 : Low	Assessment of existing scenario hence no mitigation set out.		May happen: Once every 5-10 years	Serious harm: Serious injury or illness, substantial damage or loss	9 : Low	Existing layout has technology to detect queues and reduce speed limits
5	Operation	Swooping into first exit (A50) following last moment lane changing	Side swipes	Users	Yes	May happen: Once every 5-10 years	Moderate harm: Slight injury or illness, moderate damage or loss	6 : Low	Assessment of existing scenario hence no mitigation set out.		May happen: Once every 5-10 years	Moderate harm: Slight injury or illness, moderate damage or loss	6 : Low	
6	Operation	Swooping into first exit (A50) following last moment lane changing	Loss of control	Users	Yes	Unlikely: Less than 1 per 10 years	Serious harm: Serious injury or illness, substantial damage or loss	6 : Low	Assessment of existing scenario hence no mitigation set out.		Unlikely: Less than 1 per 10 years	Serious harm: Serious injury or illness, substantial damage or loss	6 : Low	
7	Operation	Missed first exit (A50) and driver panics or attempts reverse	Multi vehicle incident	Users	No	Risk not present	Risk not present	0 : Not present			Risk not present	Risk not present	0 : Not present	Risk not present as it is a ghost island diverge to J24
8	Operation	Driver enters first (A50) exit by mistake and changes lane back	Side swipes	Users	Yes	Unlikely: Less than 1 per 10 years	Moderate harm: Slight injury or illness, moderate damage or loss	4 : Low	Assessment of existing scenario hence no mitigation set out.		Unlikely: Less than 1 per 10 years	Moderate harm: Slight injury or illness, moderate damage or loss	4 : Low	Risk present in current layout due to having first exit signed A50 and second A453
9	Operation	Live lane breakdown	Collisions with stranded vehicle	Users	Yes	May happen: Once every 5-10 years	Serious harm: Serious injury or illness, substantial damage or loss	9 : Low	Assessment of existing scenario hence no mitigation set out.		May happen: Once every 5-10 years	Serious harm: Serious injury or illness, substantial damage or loss	9 : Low	No existing hard shoulder over extent of diverge
10	Operation	Live lane breakdown	Collisions with pedestrian from stranded vehicle	Users	Yes	Unlikely: Less than 1 per 10 years	Major harm: Fatal injury, major damage or loss	8 : Low	Assessment of existing scenario hence no mitigation set out.		Unlikely: Less than 1 per 10 years	Major harm: Fatal injury, major damage or loss	8 : Low	No existing hard shoulder over extent of diverge

Safety Risk Assessment

Project Name	EMG2
BWB Project Number	220500
Design Element	M1 NB diverge layout at J24/24A
Option / Part Reference	2
Option / Part Description	Option A: J24A taper diverge followed by J24 taper diverge (Compliant diverge spacing)

Current design stage	Detailed Design
Notes	

Unique Ref.	Phase	Hazard description (before mitigation)	Incident type	Hazard affects	Is risk present in this option?	Risk without mitigation			Mitigation measures	Mitigation type	Risk with mitigation			Designer comments and assumptions
						Likelihood	Severity	Score			Likelihood	Severity	Score	
1	Operation	Frequent lane changing over short distances	Side swipes	Users	Yes	Likely: Once every 1-4 years	Moderate harm: Slight injury or illness, moderate damage or loss	8 : Low	Improved signage and signalling, hard shoulder reinstated	Reduce	May happen: Once every 5-10 years	Moderate harm: Slight injury or illness, moderate damage or loss	6 : Low	
2	Operation	Flow breakdown due to weaving and queuing on approach to first (A50) exit	Rear shunts or side swipes	Users	Yes	Likely: Once every 1-4 years	Moderate harm: Slight injury or illness, moderate damage or loss	8 : Low	Improved signage and signalling, hard shoulder reinstated	Reduce	May happen: Once every 5-10 years	Moderate harm: Slight injury or illness, moderate damage or loss	6 : Low	
3	Operation	Flow breakdown due to weaving and queuing on approach to first (A50) exit	High speed swerves with loss of control	Users	Yes	May happen: Once every 5-10 years	Serious harm: Serious injury or illness, substantial damage or loss	9 : Low	Improved signage and signalling, hard shoulder reinstated	Reduce	Unlikely: Less than 1 per 10 years	Serious harm: Serious injury or illness, substantial damage or loss	6 : Low	
4	Operation	J24 exit slip queuing back onto mainline	Rear shunts or multi vehicle incidents	Users	Yes	Very unlikely: Highly improbable, not known to occur	Serious harm: Serious injury or illness, substantial damage or loss	3 : Low			Very unlikely: Highly improbable, not known to occur	Serious harm: Serious injury or illness, substantial damage or loss	3 : Low	Robust microsimulation modelling shows queuing to the traffic signals will be contained within length of slip road
5	Operation	Swooping into first exit (A50) following last moment lane changing	Side swipes	Users	Yes	Likely: Once every 1-4 years	Moderate harm: Slight injury or illness, moderate damage or loss	8 : Low	Improved signage and signalling, hard shoulder reinstated	Reduce	May happen: Once every 5-10 years	Moderate harm: Slight injury or illness, moderate damage or loss	6 : Low	
6	Operation	Swooping into first exit (A50) following last moment lane changing	Loss of control	Users	Yes	May happen: Once every 5-10 years	Serious harm: Serious injury or illness, substantial damage or loss	9 : Low	Improved signage and signalling, hard shoulder reinstated		May happen: Once every 5-10 years	Serious harm: Serious injury or illness, substantial damage or loss	9 : Low	
7	Operation	Missed first exit (A50) and driver panics or attempts reverse	Multi vehicle incident	Users	Yes	Unlikely: Less than 1 per 10 years	Major harm: Fatal injury, major damage or loss	8 : Low	Improved signage and signalling, hard shoulder reinstated. Ensure A50 is signed on J24 exit slip road to aid navigation of J24 if driver takes 2nd exit	Reduce	Very unlikely: Highly improbable, not known to occur	Major harm: Fatal injury, major damage or loss	4 : Low	Risk very unlikely as next exit, with access to all routes, is immediately ahead
8	Operation	Driver enters first (A50) exit by mistake and changes lane back	Side swipes	Users	Yes	May happen: Once every 5-10 years	Moderate harm: Slight injury or illness, moderate damage or loss	6 : Low	Improved signage and signalling, hard shoulder reinstated	Reduce	Unlikely: Less than 1 per 10 years	Moderate harm: Slight injury or illness, moderate damage or loss	4 : Low	
9	Operation	Live lane breakdown	Collisions with stranded vehicle	Users	Yes	May happen: Once every 5-10 years	Serious harm: Serious injury or illness, substantial damage or loss	9 : Low	Hard shoulder reinstated over diverge	Reduce	Unlikely: Less than 1 per 10 years	Serious harm: Serious injury or illness, substantial damage or loss	6 : Low	
10	Operation	Live lane breakdown	Collisions with pedestrian from stranded vehicle	Users	Yes	Unlikely: Less than 1 per 10 years	Major harm: Fatal injury, major damage or loss	8 : Low	Hard shoulder reinstated over diverge	Reduce	Very unlikely: Highly improbable, not known to occur	Major harm: Fatal injury, major damage or loss	4 : Low	

Safety Risk Assessment

Project Name	EMG2
BWB Project Number	220500
Design Element	M1 NB diverge layout at J24/24A
Option / Part Reference	3
Option / Part Description	Option C: J24A auxiliary lane diverge followed by J24 taper diverge

Current design stage	Detailed Design
Notes	

Unique Ref.	Phase	Hazard description (before mitigation)	Incident type	Hazard affects	Is risk present in this option?	Risk without mitigation			Mitigation measures	Mitigation type	Risk with mitigation			Designer comments and assumptions
						Likelihood	Severity	Score			Likelihood	Severity	Score	
1	Operation	Frequent lane changing over short distances	Side swipes	Users	Yes	Likely: Once every 1-4 years	Moderate harm: Slight injury or illness, moderate damage or loss	8 : Low	Improved signage and signalling, hard shoulder reinstated	Reduce	May happen: Once every 5-10 years	Moderate harm: Slight injury or illness, moderate damage or loss	6 : Low	
2	Operation	Flow breakdown due to weaving and queuing on approach to first (A50) exit	Rear shunts or side swipes	Users	Yes	Likely: Once every 1-4 years	Moderate harm: Slight injury or illness, moderate damage or loss	8 : Low	Improved signage and signalling, hard shoulder reinstated	Reduce	May happen: Once every 5-10 years	Moderate harm: Slight injury or illness, moderate damage or loss	6 : Low	
3	Operation	Flow breakdown due to weaving and queuing on approach to first (A50) exit	High speed swerves with loss of control	Users	Yes	May happen: Once every 5-10 years	Serious harm: Serious injury or illness, substantial damage or loss	9 : Low	Improved signage and signalling, hard shoulder reinstated	Reduce	Unlikely: Less than 1 per 10 years	Serious harm: Serious injury or illness, substantial damage or loss	6 : Low	
4	Operation	J24 exit slip queuing back onto mainline	Rear shunts or multi vehicle incidents	Users	Yes	Very unlikely: Highly improbable, not known to occur	Serious harm: Serious injury or illness, substantial damage or loss	3 : Low			Very unlikely: Highly improbable, not known to occur	Serious harm: Serious injury or illness, substantial damage or loss	3 : Low	Robust microsimulation modelling shows queuing to the traffic signals will be contained within length of slip road
5	Operation	Swooping into first exit (A50) following last moment lane changing	Side swipes	Users	Yes	May happen: Once every 5-10 years	Moderate harm: Slight injury or illness, moderate damage or loss	6 : Low	Improved signage and signalling, hard shoulder reinstated	Reduce	Unlikely: Less than 1 per 10 years	Moderate harm: Slight injury or illness, moderate damage or loss	4 : Low	Risk lower prior to mitigation due to increase weaving length with auxiliary lane
6	Operation	Swooping into first exit (A50) following last moment lane changing	Loss of control	Users	Yes	Unlikely: Less than 1 per 10 years	Serious harm: Serious injury or illness, substantial damage or loss	6 : Low	Improved signage and signalling, hard shoulder reinstated		Unlikely: Less than 1 per 10 years	Serious harm: Serious injury or illness, substantial damage or loss	6 : Low	Risk lower prior to mitigation due to increase weaving length with auxiliary lane
7	Operation	Missed first exit (A50) and driver panics or attempts reverse	Multi vehicle incident	Users	Yes	Unlikely: Less than 1 per 10 years	Major harm: Fatal injury, major damage or loss	8 : Low	Improved signage and signalling, hard shoulder reinstated. Ensure A50 is signed on J24 exit slip road to aid navigation of J24 if driver takes 2nd exit	Reduce	Very unlikely: Highly improbable, not known to occur	Major harm: Fatal injury, major damage or loss	4 : Low	Risk without mitigation is unlikely as next exit, with access to all routes, is immediately ahead
8	Operation	Driver enters first (A50) exit by mistake and changes lane back	Side swipes	Users	Yes	May happen: Once every 5-10 years	Moderate harm: Slight injury or illness, moderate damage or loss	6 : Low	Improved signage and signalling, hard shoulder reinstated	Reduce	Unlikely: Less than 1 per 10 years	Moderate harm: Slight injury or illness, moderate damage or loss	4 : Low	
9	Operation	Live lane breakdown	Collisions with stranded vehicle	Users	Yes	May happen: Once every 5-10 years	Serious harm: Serious injury or illness, substantial damage or loss	9 : Low	Hard shoulder reinstated over diverge	Reduce	Unlikely: Less than 1 per 10 years	Serious harm: Serious injury or illness, substantial damage or loss	6 : Low	
10	Operation	Live lane breakdown	Collisions with pedestrian from stranded vehicle	Users	Yes	Unlikely: Less than 1 per 10 years	Major harm: Fatal injury, major damage or loss	8 : Low	Hard shoulder reinstated over diverge	Reduce	Very unlikely: Highly improbable, not known to occur	Major harm: Fatal injury, major damage or loss	4 : Low	

Safety Risk Assessment

Project Name	EMG2
BWB Project Number	220500
Design Element	M1 NB diverge layout at J24/24A
Option / Part Reference	4
Option / Part Description	CD 122 compliant scheme (2km min weaving)

Current design stage	Detailed Design
Notes	

Unique Ref.	Phase	Hazard description (before mitigation)	Incident type	Hazard affects	Is risk present in this option?	Risk without mitigation			Mitigation measures	Mitigation type	Risk with mitigation			Designer comments and assumptions
						Likelihood	Severity	Score			Likelihood	Severity	Score	
1	Operation	Frequent lane changing over short distances	Side swipes	Users	Yes	May happen: Once every 5-10 years	Moderate harm: Slight injury or illness, moderate damage or loss	6 : Low	Compliant scheme so no mitigation proposed		May happen: Once every 5-10 years	Moderate harm: Slight injury or illness, moderate damage or loss	6 : Low	Weaving will still occur so risk is present
2	Operation	Flow breakdown due to weaving and queuing on approach to first (A50) exit	Rear shunts or side swipes	Users	Yes	May happen: Once every 5-10 years	Moderate harm: Slight injury or illness, moderate damage or loss	6 : Low	Compliant scheme so no mitigation proposed		May happen: Once every 5-10 years	Moderate harm: Slight injury or illness, moderate damage or loss	6 : Low	Weaving will still occur so risk is present
3	Operation	Flow breakdown due to weaving and queuing on approach to first (A50) exit	High speed swerves with loss of control	Users	Yes	Unlikely: Less than 1 per 10 years	Serious harm: Serious injury or illness, substantial damage or loss	6 : Low	Compliant scheme so no mitigation proposed		Unlikely: Less than 1 per 10 years	Serious harm: Serious injury or illness, substantial damage or loss	6 : Low	Weaving will still occur so risk is present
4	Operation	J24 exit slip queuing back onto mainline	Rear shunts or multi vehicle incidents	Users	Yes	Very unlikely: Highly improbable, not known to occur	Serious harm: Serious injury or illness, substantial damage or loss	3 : Low	Compliant scheme so no mitigation proposed		Very unlikely: Highly improbable, not known to occur	Serious harm: Serious injury or illness, substantial damage or loss	3 : Low	Assumes queuing back from J24 slip is very unlikely in a compliant scenario
5	Operation	Swooping into first exit (A50) following last moment lane changing	Side swipes	Users	Yes	Unlikely: Less than 1 per 10 years	Moderate harm: Slight injury or illness, moderate damage or loss	4 : Low	Compliant scheme so no mitigation proposed		Unlikely: Less than 1 per 10 years	Moderate harm: Slight injury or illness, moderate damage or loss	4 : Low	Risk is present but likelihood reduced with compliant scheme which has an increased weaving length
6	Operation	Swooping into first exit (A50) following last moment lane changing	Loss of control	Users	Yes	Unlikely: Less than 1 per 10 years	Serious harm: Serious injury or illness, substantial damage or loss	6 : Low	Compliant scheme so no mitigation proposed		Unlikely: Less than 1 per 10 years	Serious harm: Serious injury or illness, substantial damage or loss	6 : Low	Risk is present but likelihood reduced with compliant scheme which has an increased weaving length
7	Operation	Missed first exit (A50) and driver panics or attempts reverse	Multi vehicle incident	Users	Yes	Very unlikely: Highly improbable, not known to occur	Major harm: Fatal injury, major damage or loss	4 : Low	Compliant scheme so no mitigation proposed		Very unlikely: Highly improbable, not known to occur	Major harm: Fatal injury, major damage or loss	4 : Low	Compliant scenario is no different to proposed in this regard
8	Operation	Driver enters first (A50) exit by mistake and changes lane back	Side swipes	Users	Yes	Unlikely: Less than 1 per 10 years	Moderate harm: Slight injury or illness, moderate damage or loss	4 : Low	Compliant scheme so no mitigation proposed		Unlikely: Less than 1 per 10 years	Moderate harm: Slight injury or illness, moderate damage or loss	4 : Low	Compliant scenario is no different to proposed in this regard
9	Operation	Live lane breakdown	Collisions with stranded vehicle	Users	Yes	Unlikely: Less than 1 per 10 years	Serious harm: Serious injury or illness, substantial damage or loss	6 : Low	Compliant scheme so no mitigation proposed		Unlikely: Less than 1 per 10 years	Serious harm: Serious injury or illness, substantial damage or loss	6 : Low	Assumes hard shoulder is provided
10	Operation	Live lane breakdown	Collisions with pedestrian from stranded vehicle	Users	Yes	Very unlikely: Highly improbable, not known to occur	Major harm: Fatal injury, major damage or loss	4 : Low	Compliant scheme so no mitigation proposed		Very unlikely: Highly improbable, not known to occur	Major harm: Fatal injury, major damage or loss	4 : Low	Assumes hard shoulder is provided

Table D1 - Risk Value, likelihood and severity of outcomes that may be assigned to qualitative data for the purpose of assessment

Likelihood (L) x Severity (S) = Risk value (R)		Severity (S)				
		Minor Harm, Minor Damage or loss no injury	Moderate harm - slight injury or illness, moderate damage or loss	Serious harm - serious injury or illness, substantial loss or damage	Major harm - Fatal injury, major damage or loss	Extreme harm - Multiple fatalities, extreme loss or damage
Likelihood (L)	Very Unlikely - Highly Improbable not known to occur	1	2	3	4	5
	Unlikely - less than 1 per 10 years	2	4	6	8	10
	May Happen - Once every 5-10 years	3	6	9	12	15
	Likely - Once every 1-4 years	4	8	12	16	20
	Almost Certain - Once a year or more	5	10	15	20	25
Risk Value (R)		Required Action				
Low (1-9)		Ensure assumed control measures are maintained and reviewed as necessary				
Medium (10-19)		Additional control measures needed to reduce risk rating to a level which is equivalent to a test of "reasonably required" for the population concerned				
High (20-25)		Activity not permitted. Hazard avoided or risk to be reduced to tolerable				

APPENDIX 2: Safety Risk Assessment for M1 J23A-24 northbound number of lanes in the weaving length and the J24A northbound diverge type

Safety Risk Assessment: GG104	GG104 version 0.1.0
Document reference	EMG2-BWB-GHS-XX-RA-CH-0004
Assessor	
Contact email	
Title of scheme	EMG2
BWB project number	220500
Part of scheme this applies to	M1 NB J23A-24 number of lanes in weaving section and diverge layout type
Location (map reference)	
Scope and purpose of this safety risk assessment	The purpose of this risk assessment is to assess the number of lanes in the weaving section and the diverge layout type
Safety objective	To manage the risk to affected parties as low as reasonably practicable.

Safety baseline: general comments	<p>PIC data: Circa 6 years of accident data has been obtained and this is for the period 1st January 2019 to 23rd October 2024 for the M1 northbound from J23A and to just beyond the J24 diverge.</p> <p>There is a cluster of PICs at the J24 northbound exit slip road and queuing back onto the M1 northbound mainline from the slip road is a regular occurrence at this location.</p>
Any recent changes in last 5 years that could affect safety?	None

Activity category	Type A
Features that need detailed review	2 Type B and 0 Type C

Principal hazard(s)	The principal hazards are flow breakdown due to the reduced number of lanes, swooping/late lane changing into the diverge and live lane breakdowns
Project description / background / objectives / outcomes	The purpose of the J24 improvements is to increase capacity to then facilitate EMG2. The main element of the works is to provide a free-flow link road from the M1 Northbound to A50 Westbound, taking this traffic out of the signalised roundabout (it is the only movement between the M1 and A50 that goes through the roundabout).

Populations affected	How is it affected and is there a specific safety objective?
Workers	Risks to workers shall be as low as reasonably practicable
Users	See principal hazard and objectives above
Other parties	No other parties are identified
Sub-populations - List	

Options / part of scheme to be assessed	Description of option / part of scheme
Option / Part 1	Existing situation - 4 lanes with layout B diverge at J24
Option / Part 2	Option C - 4 lanes with two layout A diverges (24A & 24)
Option / Part 3	Option E - 5 lanes with J24A lane drop and J24 taper diverge (Compliant Layout)
Option / Part 4	
Option / Part 5	
Preferred option (if options are assessed)	Option / Part 2 Option C - 4 lanes with two layout A diverges (24A & 24)
How type B or C features (if any) affect option selection	Type B features are because it does not comply with standards on a key route
State clear and precise reasons for selection	Option 2 reduces risks below the existing layout due to the reinstatement of the hard shoulder. It is marginally safer than a 5 lane layout as that has an increased risk of live lane breakdowns if vehicles are unable to move onto the hard shoulder.

Appraisal	
Are all risks for preferred option or parts as low as reasonably practicable following mitigation?	Yes
How have type B or C features (if any) been addressed?	Yes
Final recommendation for approval	
Recommendation	Option 2 should be progressed.
Any other comments / recommendations	The assessment shows that the risks in the proposed scheme following mitigation are lower than the existing and an option with 5 lanes.

Date	19.02.26
Revision	P02
Status	S4

Safety baseline for M1 NB mainline for extents of scheme			
Years	2019-2024		
Slight	10		
Serious	3		
Fatal	0		
Map of PICs for last 5 years			
			

No. risks	Total risk score		Average risk score across all risks		No. risks eliminated
	Before mitigation	After mitigation	Before mitigation	After mitigation	
7	51	51	6.4	6.4	0
8	59	44	7.4	5.5	0
8	45	45	5.6	5.6	0
0	0	0			0
0	0	0			0

Feature (Table E/2.7)	Type	Indicator	Justification for choice of feature type	Select Type
Extent of prior experience of activity The degree of knowledge available from undertaking the activity previously or the degree to which knowledge is available from the activity being undertaken by other industries or organisations.	A	Activities for which there is significant experience within National Highways. Previous safety studies and data are available, and some activity features are codified in a standard or formal procedure.	Weaving and diverge layouts are a common feature	A
	B	Activities for which there is limited experience within National Highways but there is transferable experience elsewhere in the UK or internationally. Activities for which there is limited experience in National Highways but there is experience elsewhere in the UK or internationally, including in different industries, which is deemed sufficiently similar to the activity in question to be deemed relevant. Activities for which there is experience within National Highways but that experience is in a different application of the activity and some adaptation will be required. There might also be local and site specific issues to take into account that can affect the relevance of the available experience		
	C	Activities for which there is no previous applicable experience from either National Highways or other industries.		
Statutory and formal processes and procedures (including standards and legislation) Consideration of the applicability of current standards, formal processes or procedures, guidance and legislation.	A	The activity is substantially or entirely within the scope of existing standards, guidance, formal processes or procedures and applicable legislation. The activity requires minimal or no safety related departures from standard or safety related changes to formal processes or procedures (including any legislation).	Reduction in number of lanes over the weaving length and the diverge layout type are departures	B
	B	The activity is largely within the scope of existing standards, guidance, formal processes or procedures. There can be some safety related departures from standards needed and/or safety related changes to formal processes or procedures. The activity can need minor changes to existing legislation.		
	C	Activities that are not within the scope of existing standards, formal processes or procedures and require new ones to be developed. Activities for which significant departures from standards, formal processes or procedures are required. Activities which require significant changes to existing legislation or new legislation to be written. Whilst the number of safety departures from standards, formal processes or procedures can affect the categorisation, the most important element in determining this is the nature and type of the departures. For example, a large number of safety departures that can be addressed straightforwardly will have less impact on feature type than a single safety departure that cannot and requires a detailed risk assessment to support it.		
Impact on the organisation The effect that the activity will have on current Highways England processes, procedures, structure, roles and responsibilities, competencies, policies and strategy, in addition to contractual and workforce arrangements.	A	The activity has no impact on National Highways. The activity has a minor impact on any of these for a finite period of time. Length of time National Highways is affected by decision to undertake the activity is short term.	No impact identified for National Highways	A
	B	The activity can lead to permanent minor changes to any of these. These minor changes can introduce new roles and responsibilities, policies, contractual and workforce arrangements. The activity can require a change to organisational arrangements. Length of time National Highways is affected by decision to undertake the activity is medium term.		
	C	The activity has significant impact on any of these. The activity can change core safety roles and responsibilities. Length of time National Highways is affected by decision to undertake the activity is long term.		
Activity scale Consideration of the size and/or scale of the activity. Does or can the activity have an impact on the motorway and all-purpose trunk roads, either directly or indirectly.	A	The impact of the activity is limited in nature or scale.	This covers a key section of the M1 hence it is arguably a B feature	B
	B	The impact of the activity is significant in nature or scale.		
	C	The impact of the activity is wide ranging across the network, and/or significantly impacts infrastructure, interventions or workforce.		
Technical Measure of technical and/or technological novelty and/or innovation the activity involves.	A	An activity where any processes, techniques, methodologies and/or technologies involved are currently in widespread use and re-examination is unlikely to be needed. There can be some experience of the processes, techniques, methodologies and/or technologies.	Such layouts are in widespread use and doesn't involve new technologies.	A
	B	The experience can be from use in either another application, or by another road authority, supplier, industry or perhaps from overseas in which case some additional work can be required to adapt them and/or to demonstrate that safety can be assured for the intended application.		
	C	Activities that use new processes, techniques, methodologies and/or technologies for which there is no previous experience in the UK or elsewhere.		
Stakeholder impact and interest The quantity and/or impact of stakeholders, their interest in and resulting ability to influence or/impact on the activity. The degree to which the safety issues, as perceived, are capable of being understood and fully addressed.	A	Activities for which the quantity and/or impact of stakeholders, their interest in and resulting ability to influence or impact the activity is low Activities that have only a single or a few stakeholders but their impact, in terms of their attitude towards, or ability to influence, and/or interest in the successful achievement of the activities aim can be significant.	Minimal impact to stakeholders.	A
	B	Alternatively it will represent an activity that has several stakeholders but the amount, or type, of safety issues involved are limited. Activities for which there are a large number of stakeholders and their impact in terms of their attitude towards, or ability to influence can be significant.		
	C	Stakeholders with a strong interest in the potential safety impact of the activity on themselves. Activities where there are conflicting needs arising from different stakeholders or stakeholder groups.		

Type A features	4
Type B features	2
Type C features	0

Table E/2.8.1 category type	Type A
No. other features to be reviewed in more detail	2 Type B and 0 Type C
Final category decision	Type A

Safety Risk Assessment

Project Name	EMG2
BWB Project Number	220500
Design Element	M1 NB J23A-24 number of lanes in weaving section and diverge layout type

Unique Ref.	Phase	Hazard description (before mitigation)	Incident type	Hazard affects	Designer comments and assumptions
1	Operation	Frequent lane changing over short distances	Side swipes	Users	
2	Operation	Flow breakdown due to weaving	Rear shunts or side swipes	Users	
3	Operation	Flow breakdown due to weaving	High speed swerves with loss of control	Users	
4	Operation	Swooping into first exit (A50) following last moment lane changing	Side swipes	Users	
5	Operation	Swooping into first exit (A50) following last moment lane changing	Loss of control	Users	
6	Operation	Missed first exit (A50) and driver panics or attempts reverse	Multi vehicle incident	Users	
7	Operation	Live lane breakdown	Collisions with stranded vehicle	Users	In the existing situation the hard shoulder terminates south of the A6 Kegworth Bypass bridge
8	Operation	Live lane breakdown	Collisions with pedestrian from stranded vehicle	Users	In the existing situation the hard shoulder terminates south of the A6 Kegworth Bypass bridge

Safety Risk Assessment

Project Name	EMG2
BWB Project Number	220500
Design Element	M1 NB J23A-24 number of lanes in weaving section and diverge layout type
Option / Part Reference	1
Option / Part Description	Existing situation - 4 lanes with layout B diverge at J24

Current design stage	Detailed Design
Notes	

Unique Ref.	Phase	Hazard description (before mitigation)	Incident type	Hazard affects	Is risk present in this option?	Risk without mitigation			Mitigation measures	Mitigation type	Risk with mitigation			Designer comments and assumptions
						Likelihood	Severity	Score			Likelihood	Severity	Score	
1	Operation	Frequent lane changing over short distances	Side swipes	Users	Yes	Likely: Once every 1-4 years	Moderate harm: Slight injury or illness, moderate damage or loss	8 : Low	Assessment of existing scenario hence no mitigation set out.		Likely: Once every 1-4 years	Moderate harm: Slight injury or illness, moderate damage or loss	8 : Low	Likelihood based on PIC data for existing layout.
2	Operation	Flow breakdown due to weaving	Rear shunts or side swipes	Users	Yes	Likely: Once every 1-4 years	Moderate harm: Slight injury or illness, moderate damage or loss	8 : Low	Assessment of existing scenario hence no mitigation set out.		Likely: Once every 1-4 years	Moderate harm: Slight injury or illness, moderate damage or loss	8 : Low	Likelihood based on PIC data for existing layout. Existing layout has technology to detect queues and reduce speed limits
3	Operation	Flow breakdown due to weaving	High speed swerves with loss of control	Users	Yes	Unlikely: Less than 1 per 10 years	Serious harm: Serious injury or illness, substantial damage or loss	6 : Low	Assessment of existing scenario hence no mitigation set out.		Unlikely: Less than 1 per 10 years	Serious harm: Serious injury or illness, substantial damage or loss	6 : Low	Likelihood based on PIC data for existing layout. Existing layout has technology to detect queues and reduce speed limits
4	Operation	Swooping into first exit (A50) following last moment lane changing	Side swipes	Users	Yes	May happen: Once every 5-10 years	Moderate harm: Slight injury or illness, moderate damage or loss	6 : Low	Assessment of existing scenario hence no mitigation set out.		May happen: Once every 5-10 years	Moderate harm: Slight injury or illness, moderate damage or loss	6 : Low	
5	Operation	Swooping into first exit (A50) following last moment lane changing	Loss of control	Users	Yes	Unlikely: Less than 1 per 10 years	Serious harm: Serious injury or illness, substantial damage or loss	6 : Low	Assessment of existing scenario hence no mitigation set out.		Unlikely: Less than 1 per 10 years	Serious harm: Serious injury or illness, substantial damage or loss	6 : Low	
6	Operation	Missed first exit (A50) and driver panics or attempts reverse	Multi vehicle incident	Users	No	Risk not present	Risk not present	0 : Not present			Risk not present	Risk not present	0 : Not present	
7	Operation	Live lane breakdown	Collisions with stranded vehicle	Users	Yes	May happen: Once every 5-10 years	Serious harm: Serious injury or illness, substantial damage or loss	9 : Low	Assessment of existing scenario hence no mitigation set out.		May happen: Once every 5-10 years	Serious harm: Serious injury or illness, substantial damage or loss	9 : Low	
8	Operation	Live lane breakdown	Collisions with pedestrian from stranded vehicle	Users	Yes	Unlikely: Less than 1 per 10 years	Major harm: Fatal injury, major damage or loss	8 : Low	Assessment of existing scenario hence no mitigation set out.		Unlikely: Less than 1 per 10 years	Major harm: Fatal injury, major damage or loss	8 : Low	

Safety Risk Assessment

Project Name	EMG2
BWB Project Number	220500
Design Element	M1 NB J23A-24 number of lanes in weaving section and diverge layout type
Option / Part Reference	2
Option / Part Description	Option C - 4 lanes with two layout A diverges (24A & 24)

Current design stage	Detailed Design
Notes	

Unique Ref.	Phase	Hazard description (before mitigation)	Incident type	Hazard affects	Is risk present in this option?	Risk without mitigation			Mitigation measures	Mitigation type	Risk with mitigation			Designer comments and assumptions
						Likelihood	Severity	Score			Likelihood	Severity	Score	
1	Operation	Frequent lane changing over short distances	Side swipes	Users	Yes	Likely: Once every 1-4 years	Moderate harm: Slight injury or illness, moderate damage or loss	8 : Low	Additional gantry with directional signage and above lane signals closer to J23A merge		Likely: Once every 1-4 years	Moderate harm: Slight injury or illness, moderate damage or loss	8 : Low	Existing technology is retained and supplemented; mitigation not considered to reduce likelihood
2	Operation	Flow breakdown due to weaving	Rear shunts or side swipes	Users	Yes	Likely: Once every 1-4 years	Moderate harm: Slight injury or illness, moderate damage or loss	8 : Low	Additional gantry with directional signage and above lane signals closer to J23A merge	Reduce	May happen: Once every 5-10 years	Moderate harm: Slight injury or illness, moderate damage or loss	6 : Low	Existing technology is retained and supplemented
3	Operation	Flow breakdown due to weaving	High speed swerves with loss of control	Users	Yes	Unlikely: Less than 1 per 10 years	Serious harm: Serious injury or illness, substantial damage or loss	6 : Low	Additional gantry with directional signage and above lane signals closer to J23A merge		Unlikely: Less than 1 per 10 years	Serious harm: Serious injury or illness, substantial damage or loss	6 : Low	Existing technology is retained and supplemented; mitigation not considered to reduce likelihood as it is already low
4	Operation	Swooping into first exit (A50) following last moment lane changing	Side swipes	Users	Yes	May happen: Once every 5-10 years	Moderate harm: Slight injury or illness, moderate damage or loss	6 : Low	Improved signage and signalling, hard shoulder reinstated	Reduce	Unlikely: Less than 1 per 10 years	Moderate harm: Slight injury or illness, moderate damage or loss	4 : Low	
5	Operation	Swooping into first exit (A50) following last moment lane changing	Loss of control	Users	Yes	Unlikely: Less than 1 per 10 years	Serious harm: Serious injury or illness, substantial damage or loss	6 : Low	Improved signage and signalling, hard shoulder reinstated downstream of Ashby Road bridge	Reduce	Unlikely: Less than 1 per 10 years	Serious harm: Serious injury or illness, substantial damage or loss	6 : Low	Mitigation is beneficial but not considered to change likelihood
6	Operation	Missed first exit (A50) and driver panics or attempts reverse	Multi vehicle incident	Users	Yes	Unlikely: Less than 1 per 10 years	Major harm: Fatal injury, major damage or loss	8 : Low	Improved signage and signalling, hard shoulder reinstated. Ensure A50 is signed on J24 exit slip road to aid navigation of J24 if driver takes 2nd exit	Reduce	Very unlikely: Highly improbable, not known to occur	Major harm: Fatal injury, major damage or loss	4 : Low	Risk very unlikely as next exit, with access to all routes, is immediately ahead
7	Operation	Live lane breakdown	Collisions with stranded vehicle	Users	Yes	May happen: Once every 5-10 years	Serious harm: Serious injury or illness, substantial damage or loss	9 : Low	Hard shoulder reinstated downstream of Ashby Road bridge	Reduce	Unlikely: Less than 1 per 10 years	Serious harm: Serious injury or illness, substantial damage or loss	6 : Low	Hard shoulder reinstated from north of Ashby Road bridge up to J24 diverge nose
8	Operation	Live lane breakdown	Collisions with pedestrian from stranded vehicle	Users	Yes	Unlikely: Less than 1 per 10 years	Major harm: Fatal injury, major damage or loss	8 : Low	Hard shoulder reinstated downstream of Ashby Road bridge	Reduce	Very unlikely: Highly improbable, not known to occur	Major harm: Fatal injury, major damage or loss	4 : Low	Hard shoulder reinstated from north of Ashby Road bridge up to J24 diverge nose

Safety Risk Assessment

Project Name	EMG2
BWB Project Number	220500
Design Element	M1 NB J23A-24 number of lanes in weaving section and diverge layout type
Option / Part Reference	3
Option / Part Description	Option E - 5 lanes with J24A lane drop and J24 taper diverge (Compliant Layout)

Current design stage	Detailed Design
Notes	

Unique Ref.	Phase	Hazard description (before mitigation)	Incident type	Hazard affects	Is risk present in this option?	Risk without mitigation			Mitigation measures	Mitigation type	Risk with mitigation			Designer comments and assumptions
						Likelihood	Severity	Score			Likelihood	Severity	Score	
1	Operation	Frequent lane changing over short distances	Side swipes	Users	Yes	Likely: Once every 1-4 years	Moderate harm: Slight injury or illness, moderate damage or loss	8 : Low	None as scheme would have compliant number of lanes		Likely: Once every 1-4 years	Moderate harm: Slight injury or illness, moderate damage or loss	8 : Low	Likelihood remains high due to increased number of lanes
2	Operation	Flow breakdown due to weaving	Rear shunts or side swipes	Users	Yes	May happen: Once every 5-10 years	Moderate harm: Slight injury or illness, moderate damage or loss	6 : Low	None as scheme would have compliant number of lanes		May happen: Once every 5-10 years	Moderate harm: Slight injury or illness, moderate damage or loss	6 : Low	Assumes controlled motorway technology remains in place
3	Operation	Flow breakdown due to weaving	High speed swerves with loss of control	Users	Yes	Unlikely: Less than 1 per 10 years	Serious harm: Serious injury or illness, substantial damage or loss	6 : Low	None as scheme would have compliant number of lanes		Unlikely: Less than 1 per 10 years	Serious harm: Serious injury or illness, substantial damage or loss	6 : Low	Assumes controlled motorway technology remains in place
4	Operation	Swooping into first exit (A50) following last moment lane changing	Side swipes	Users	Yes	Unlikely: Less than 1 per 10 years	Moderate harm: Slight injury or illness, moderate damage or loss	4 : Low	None as scheme would have compliant number of lanes		Unlikely: Less than 1 per 10 years	Moderate harm: Slight injury or illness, moderate damage or loss	4 : Low	
5	Operation	Swooping into first exit (A50) following last moment lane changing	Loss of control	Users	Yes	Very unlikely: Highly improbable, not known to occur	Serious harm: Serious injury or illness, substantial damage or loss	3 : Low	None as scheme would have compliant number of lanes		Very unlikely: Highly improbable, not known to occur	Serious harm: Serious injury or illness, substantial damage or loss	3 : Low	Layout D diverge has 2nd exit which minimises the likelihood
6	Operation	Missed first exit (A50) and driver panics or attempts reverse	Multi vehicle incident	Users	Yes	Very unlikely: Highly improbable, not known to occur	Major harm: Fatal injury, major damage or loss	4 : Low	None as scheme would have compliant number of lanes		Very unlikely: Highly improbable, not known to occur	Major harm: Fatal injury, major damage or loss	4 : Low	
7	Operation	Live lane breakdown	Collisions with stranded vehicle	Users	Yes	Unlikely: Less than 1 per 10 years	Serious harm: Serious injury or illness, substantial damage or loss	6 : Low	None as scheme would have compliant number of lanes		Unlikely: Less than 1 per 10 years	Serious harm: Serious injury or illness, substantial damage or loss	6 : Low	Assumed 5 lane section has a full hard shoulder in place but hazard is more likely due to increased potential for vehicles being unable to reach the hard shoulder due to 5 lanes
8	Operation	Live lane breakdown	Collisions with pedestrian from stranded vehicle	Users	Yes	Unlikely: Less than 1 per 10 years	Major harm: Fatal injury, major damage or loss	8 : Low	None as scheme would have compliant number of lanes		Unlikely: Less than 1 per 10 years	Major harm: Fatal injury, major damage or loss	8 : Low	Assumed 5 lane section has a full hard shoulder in place but hazard is more likely due to increased potential for vehicles being unable to reach the hard shoulder due to 5 lanes

Table D1 - Risk Value, likelihood and severity of outcomes that may be assigned to qualitative data for the purpose of assessment

Likelihood (L) x Severity (S) = Risk value (R)		Severity (S)				
		Minor Harm, Minor Damage or loss no injury	Moderate harm - slight injury or illness, moderate damage or loss	Serious harm - serious injury or illness, substantial loss or damage	Major harm - Fatal injury, major damage or loss	Extreme harm - Multiple fatalities, extreme loss or damage
Likelihood (L)	Very Unlikely - Highly Improbable not known to occur	1	2	3	4	5
	Unlikely - less than 1 per 10 years	2	4	6	8	10
	May Happen - Once every 5-10 years	3	6	9	12	15
	Likely - Once every 1-4 years	4	8	12	16	20
	Almost Certain - Once a year or more	5	10	15	20	25
Risk Value (R)		Required Action				
Low (1-9)		Ensure assumed control measures are maintained and reviewed as necessary				
Medium (10-19)		Additional control measures needed to reduce risk rating to a level which is equivalent to a test of "reasonably required" for the population concerned				
High (20-25)		Activity not permitted. Hazard avoided or risk to be reduced to tolerable				

APPENDIX 3: Safety Risk Assessment for M1 NB to A50 WB interchange link

Safety Risk Assessment: GG104	GG 104 version 0.1.0
Document reference	EMG2-BWB-GHS-XX-RA-CH-0002

Date	28.11.25
Revision	P02
Status	S4

Assessor	
Contact email	

Title of scheme	EMG2
BWB project number	220500
Part of scheme this applies to	M1 NB to A50 WB interchange link
Location (map reference)	
Scope and purpose of this safety risk assessment	The purpose of this risk assessment is to assess the options for the interchange link
Safety objective	To manage the risk to affected parties as low as reasonably practicable.

Safety baseline: general comments	Not applicable as this is a new link
Any recent changes in last 5 years that could affect safety?	n/a

Activity category	Type A
Features that need detailed review	1 Type B and 0 Type C

Principal hazard(s)	Option 1 (underbridge): potential for deep water if surface water pumping fails Options 2 and 3 (overbridge): reduced SSD over the bridge and before the downstream merge
Project description / background / objectives / outcomes	The purpose of the J24 improvements is to increase capacity to then facilitate EMG2. The main element of the works is to provide a free-flow link road from the M1 Northbound to A50 Westbound, taking this traffic out of the signalised roundabout (it is the only movement between the M1 and A50 that goes through the roundabout).

Populations affected	How is it affected and is there a specific safety objective?
Workers	Risks to workers shall be as low as reasonably practicable
Users	See principal hazard and objectives above
Other parties	No other parties are identified
Sub-populations - List	

Safety baseline for M1 NB mainline for extents of			
Years			
Slight			
Serious			
Fatal			
Map of PICs for last 5 years			



Options / part of scheme to be assessed	Description of option / part of scheme
Option / Part 1	Option 1: Underbridge
Option / Part 2	Option 2: Single-span overbridge with crest curve K17
Option / Part 3	Option 3: Single-span overbridge with crest curve K30 and reduced (high load) headroom
Option / Part 4	
Option / Part 5	
Preferred option (if options are assessed)	Option / Part 3 Option 3: Single-span overbridge with crest curve K30 and reduced (high load) headroom
How type B or C features (if any) affect option selection	Type B feature for option 1 is due to the surface water pumping Type B feature for option 2 and 3 are because it does not comply with standards
State clear and precise reasons for selection	Option 3 is the overall lowest risk option

No. risks	Total risk score		Average risk score across all risks		No. risks eliminated
	Before mitigation	After mitigation	Before mitigation	After mitigation	
9	63	61	7.0	6.8	0
5	39	29	4.3	3.2	0
5	34	24	3.8	2.7	0
0	0	0			0
0	0	0			0

Appraisal	
Are all risks for preferred option or parts as low as reasonably practicable following mitigation?	Yes
How have type B or C features (if any) been addressed?	Yes
Final recommendation for approval	
Recommendation	Option 3 should be progressed.
Any other comments / recommendations	

Feature (Table E/2.7)	Type	Indicator	Justification for choice of feature type	Select Type
Extent of prior experience of activity The degree of knowledge available from undertaking the activity previously or the degree to which knowledge is available from the activity being undertaken by other industries or organisations.	A	Activities for which there is significant experience within National Highways. Previous safety studies and data are available, and some activity features are codified in a standard or formal procedure.	Reduction in K values at vertical alignment are common	A
	B	Activities for which there is limited experience within National Highways but there is transferable experience elsewhere in the UK or internationally. Activities for which there is limited experience in National Highways but there is experience elsewhere in the UK or internationally, including in different industries, which is deemed sufficiently similar to the activity in question to be deemed relevant. Activities for which there is experience within National Highways but that experience is in a different application of the activity and some adaptation will be required. There might also be local and site specific issues to take into account that can affect the relevance of the available experience		
	C	Activities for which there is no previous applicable experience from either National Highways or other industries.		
Statutory and formal processes and procedures (including standards and legislation) Consideration of the applicability of current standards, formal processes or procedures, guidance and legislation.	A	The activity is substantially or entirely within the scope of existing standards, guidance, formal processes or procedures and applicable legislation. The activity requires minimal or no safety related departures from standard or safety related changes to formal processes or procedures (including any legislation).	Reduction in crest K on interchange link is a departure	B
	B	The activity is largely within the scope of existing standards, guidance, formal processes or procedures. There can be some safety related departures from standards needed and/or safety related changes to formal processes or procedures. The activity can need minor changes to existing legislation.		
	C	Activities that are not within the scope of existing standards, formal processes or procedures and require new ones to be developed. Activities for which significant departures from standards, formal processes or procedures are required. Activities which require significant changes to existing legislation or new legislation to be written. Whilst the number of safety departures from standards, formal processes or procedures can affect the categorisation, the most important element in determining this is the nature and type of the departures. For example, a large number of safety departures that can be addressed straightforwardly will have less impact on feature type than a single safety departure that cannot and requires a detailed risk assessment to support it.		
Impact on the organisation The effect that the activity will have on current Highways England processes, procedures, structure, roles and responsibilities, competencies, policies and strategy, in addition to contractual and workforce arrangements.	A	The activity has no impact on National Highways. The activity has a minor impact on any of these for a finite period of time. Length of time National Highways is affected by decision to undertake the activity is short term.	No impact identified for National Highways	A
	B	The activity can lead to permanent minor changes to any of these. These minor changes can introduce new roles and responsibilities, policies, contractual and workforce arrangements. The activity can require a change to organisational arrangements. Length of time National Highways is affected by decision to undertake the activity is medium term.		
	C	The activity has significant impact on any of these. The activity can change core safety roles and responsibilities. Length of time National Highways is affected by decision to undertake the activity is long term.		
Activity scale Consideration of the size and/or scale of the activity. Does or can the activity have an impact on the motorway and all-purpose trunk roads, either directly or indirectly.	A	The impact of the activity is limited in nature or scale.	This is a specific localised activity	A
	B	The impact of the activity is significant in nature or scale.		
	C	The impact of the activity is wide ranging across the network, and/or significantly impacts infrastructure, interventions or workforce.		
Technical Measure of technical and/or technological novelty and/or innovation the activity involves.	A	An activity where any processes, techniques, methodologies and/or technologies involved are currently in widespread use and re-examination is unlikely to be needed. There can be some experience of the processes, techniques, methodologies and/or technologies.	Such layouts are in widespread use and doesn't involve new technologies.	A
	B	The experience can be from use in either another application, or by another road authority, supplier, industry or perhaps from overseas in which case some additional work can be required to adapt them and/or to demonstrate that safety can be assured for the intended application.		
	C	Activities that use new processes, techniques, methodologies and/or technologies for which there is no previous experience in the UK or elsewhere.		
Stakeholder impact and interest The quantity and/or impact of stakeholders, their interest in and resulting ability to influence or/impact on the activity. The degree to which the safety issues, as perceived, are capable of being understood and fully addressed.	A	Activities for which the quantity and/or impact of stakeholders, their interest in and resulting ability to influence or impact the activity is low	Minimal impact to stakeholders.	A
	B	Activities that have only a single or a few stakeholders but their impact, in terms of their attitude towards, or ability to influence, and/or interest in the successful achievement of the activities aim can be significant. Alternatively it will represent an activity that has several stakeholders but the amount, or type, of safety issues involved are limited.		
	C	Activities for which there are a large number of stakeholders and their impact in terms of their attitude towards, or ability to influence can be significant. Stakeholders with a strong interest in the potential safety impact of the activity on themselves. Activities where there are conflicting needs arising from different stakeholders or stakeholder groups.		

Type A features 5
 Type B features 1
 Type C features 0

Table E/2.8.1 category type Type A
 No. other features to be reviewed in more detail 1 Type B and 0 Type C

Final category decision Type A

Safety Risk Assessment

Project Name	EMG2
BWB Project Number	220500
Design Element	M1 NB to A50 WB interchange link

Unique Ref.	Phase	Hazard description (before mitigation)	Incident type	Hazard affects	Designer comments and assumptions
1	Operation	Failure to see queuing traffic	Multi-vehicle rear-shunt incident	Users	
2	Operation	Object on the carriageway e.g. debris	Side swipe or loss of control due to impacting debris	Users	Link will be under motorway regulations
3	Operation	Collisions at merge	Side swipes	Users	Downstream merge has a lane gain
4	Operation	Bridge strike from high abnormal load vehicle (unplanned / unauthorised)	Collision with structure	Users	
5	Operation	Diversion / congestion arising from the construction of the bridge, leading to rat running and/or driver frustration resulting in vehicle collisions	Shunt, side swipe or failure to give way incidents	Users	
6	Operation	Failure of surface water pumping station leading to flooding of the underpass	Aquaplaning / loss of control: single vehicle incident	Users	Failure of pumping is unlikely but is known to happen e.g. A421
7	Operation	Failure of surface water pumping station leading to flooding of the underpass	Aquaplaning / loss of control: multi vehicle incident	Users	Failure of pumping is unlikely but is known to happen e.g. A421
8	Operation	Failure of surface water pumping station leading to flooding of the underpass	Submerged vehicle / drowning	Users	Failure of pumping is unlikely but is known to happen e.g. A421
9	Construction	Failure of surface water pumping station leading to flooding of the underpass: congestion due to link closure	General collisions on wider network	Users	

Safety Risk Assessment

Project Name	EMG2
BWB Project Number	220500
Design Element	M1 NB to A50 WB interchange link
Option / Part Reference	1
Option / Part Description	Option 1: Underbridge

Current design stage	Detailed Design
Notes	

Unique Ref.	Phase	Hazard description (before mitigation)	Incident type	Hazard affects	Is risk present in this option?	Risk without mitigation			Mitigation measures	Mitigation type	Risk with mitigation			Designer comments and assumptions
						Likelihood	Severity	Score			Likelihood	Severity	Score	
1	Operation	Failure to see queuing traffic	Multi-vehicle rear-shunt incident	Users	Yes	Unlikely: Less than 1 per 10 years	Serious harm: Serious injury or illness, substantial damage or loss	6 : Low	No specific mitigation as compliant SSD		Unlikely: Less than 1 per 10 years	Serious harm: Serious injury or illness, substantial damage or loss	6 : Low	Risk is present but unlikely due to the SSD being fully compliant
2	Operation	Object on the carriageway e.g. debris	Side swipe or loss of control due to impacting debris	Users	Yes	Unlikely: Less than 1 per 10 years	Moderate harm: Slight injury or illness, moderate damage or loss	4 : Low	No specific mitigation as compliant SSD		Unlikely: Less than 1 per 10 years	Moderate harm: Slight injury or illness, moderate damage or loss	4 : Low	Risk is present but unlikely due to the SSD being fully compliant
3	Operation	Collisions at merge	Side swipes	Users	Yes	May happen: Once every 5-10 years	Serious harm: Serious injury or illness, substantial damage or loss	9 : Low	No specific mitigation as compliant SSD		May happen: Once every 5-10 years	Serious harm: Serious injury or illness, substantial damage or loss	9 : Low	Due to the uphill approach to the merge, visibility is restricted of the layout to approximately SSD. Whilst the layout would be compliant it gives the driver less time to anticipate merging traffic than the alternative options.
4	Operation	Bridge strike from high abnormal load vehicle (unplanned / unauthorised)	Collision with structure	Users	Yes	Very unlikely: Highly improbable, not known to occur	Major harm: Fatal injury, major damage or loss	4 : Low	No specific mitigation as compliant clearance and M1 is not a high load route so upstream bridges will have standard clearance		Very unlikely: Highly improbable, not known to occur	Major harm: Fatal injury, major damage or loss	4 : Low	
5	Operation	Diversion / congestion arising from the construction of the bridge, leading to rat running and/or driver frustration resulting in vehicle collisions	Shunt, side swipe or failure to give way incidents	Users	Yes	Likely: Once every 1-4 years	Moderate harm: Slight injury or illness, moderate damage or loss	8 : Low	Compliant traffic management. Form of structure to consider speed of construction to minimise delays	Reduce	May happen: Once every 5-10 years	Moderate harm: Slight injury or illness, moderate damage or loss	6 : Low	Construction of the underbridge is assumed to take place in at least 2 phases, by reducing the number of lanes of traffic to give access to the work area. Likely to result in congestion in the local area.
6	Operation	Failure of surface water pumping station leading to flooding of the underpass	Aquaplaning / loss of control: single vehicle incident	Users	Yes	Unlikely: Less than 1 per 10 years	Major harm: Fatal injury, major damage or loss	8 : Low			Unlikely: Less than 1 per 10 years	Major harm: Fatal injury, major damage or loss	8 : Low	Base assumption is that the pumping station(s) would be designed inline with good practice and with suitable redundancies in place.
7	Operation	Failure of surface water pumping station leading to flooding of the underpass	Aquaplaning / loss of control: multi vehicle incident	Users	Yes	Unlikely: Less than 1 per 10 years	Extreme harm: Multiple fatalities, extreme loss	10 : Medium			Unlikely: Less than 1 per 10 years	Extreme harm: Multiple fatalities, extreme loss	10 : Medium	Base assumption is that the pumping station(s) would be designed inline with good practice and with suitable redundancies in place.
8	Operation	Failure of surface water pumping station leading to flooding of the underpass	Submerged vehicle / drowning	Users	Yes	Unlikely: Less than 1 per 10 years	Extreme harm: Multiple fatalities, extreme loss	10 : Medium			Unlikely: Less than 1 per 10 years	Extreme harm: Multiple fatalities, extreme loss	10 : Medium	Base assumption is that the pumping station(s) would be designed inline with good practice and with suitable redundancies in place.
9	Construction	Failure of surface water pumping station leading to flooding of the underpass: congestion due to link closure	General collisions on wider network	Users	Yes	Unlikely: Less than 1 per 10 years	Moderate harm: Slight injury or illness, moderate damage or loss	4 : Low			Unlikely: Less than 1 per 10 years	Moderate harm: Slight injury or illness, moderate damage or loss	4 : Low	Base assumption is that the pumping station(s) would be designed inline with good practice and with suitable redundancies in place.

Safety Risk Assessment

Project Name	EMG2
BWB Project Number	220500
Design Element	M1 NB to A50 WB interchange link
Option / Part Reference	2
Option / Part Description	Option 2: Single-span overbridge with crest curve K17

Current design stage	Detailed Design
Notes	

Unique Ref.	Phase	Hazard description (before mitigation)	Incident type	Hazard affects	Is risk present in this option?	Risk without mitigation			Mitigation measures	Mitigation type	Risk with mitigation			Designer comments and assumptions
						Likelihood	Severity	Score			Likelihood	Severity	Score	
1	Operation	Failure to see queuing traffic	Multi-vehicle rear-shunt incident	Users	Yes	Likely: Once every 1-4 years	Serious harm: Serious injury or illness, substantial damage or loss	12 : Medium	50mph speed limit to be provided on the interchange link; use of higher PSV surfacing (65 or 68+)	Reduce	May happen: Once every 5-10 years	Serious harm: Serious injury or illness, substantial damage or loss	9 : Low	
2	Operation	Object on the carriageway e.g. debris	Side swipe or loss of control due to impacting debris	Users	Yes	Likely: Once every 1-4 years	Moderate harm: Slight injury or illness, moderate damage or loss	8 : Low	50mph speed limit to be provided on the interchange link; use of higher PSV surfacing (65 or 68+)	Reduce	May happen: Once every 5-10 years	Moderate harm: Slight injury or illness, moderate damage or loss	6 : Low	
3	Operation	Collisions at merge	Side swipes	Users	Yes	May happen: Once every 5-10 years	Serious harm: Serious injury or illness, substantial damage or loss	9 : Low	50mph speed limit to be provided on the interchange link; use of higher PSV surfacing (65 or 68+); merge warning signing provided		Unlikely: Less than 1 per 10 years	Serious harm: Serious injury or illness, substantial damage or loss	6 : Low	The elevated view from the over bridge allows drivers time to gauge speed of traffic exiting J24, despite the reduced SSD
4	Operation	Bridge strike from high abnormal load vehicle (unplanned / unauthorised)	Collision with structure	Users	Yes	Very unlikely: Highly improbable, not known to occur	Major harm: Fatal injury, major damage or loss	4 : Low	No mitigation as compliant high load clearance		Very unlikely: Highly improbable, not known to occur	Major harm: Fatal injury, major damage or loss	4 : Low	Very unlikely as 6.45m clearance provided
5	Operation	Diversion / congestion arising from the construction of the bridge, leading to rat running and/or driver frustration resulting in vehicle collisions	Shunt, side swipe or failure to give way incidents	Users	Yes	May happen: Once every 5-10 years	Moderate harm: Slight injury or illness, moderate damage or loss	6 : Low	Compliant traffic management. Form of structure to consider speed of construction to minimise delays		Unlikely: Less than 1 per 10 years	Moderate harm: Slight injury or illness, moderate damage or loss	4 : Low	Assumed to be isolated closures for bridge beam lifts/slide
6	Operation	Failure of surface water pumping station leading to flooding of the underpass	Aquaplaning / loss of control: single vehicle incident	Users	No	Risk not present	Risk not present	0 : Not present	N/a		Risk not present	Risk not present	0 : Not present	N/a
7	Operation	Failure of surface water pumping station leading to flooding of the underpass	Aquaplaning / loss of control: multi vehicle incident	Users	No	Risk not present	Risk not present	0 : Not present	N/a		Risk not present	Risk not present	0 : Not present	N/a
8	Operation	Failure of surface water pumping station leading to flooding of the underpass	Submerged vehicle / drowning	Users	No	Risk not present	Risk not present	0 : Not present	N/a		Risk not present	Risk not present	0 : Not present	N/a
9	Construction	Failure of surface water pumping station leading to flooding of the underpass: congestion due to link closure	General collisions on wider network	Users	No	Risk not present	Risk not present	0 : Not present	N/a		Risk not present	Risk not present	0 : Not present	N/a

Safety Risk Assessment

Project Name	EMG2
BWB Project Number	220500
Design Element	M1 NB to A50 WB interchange link
Option / Part Reference	3
Option / Part Description	Option 3: Single-span overbridge with crest curve K30 and reduced (high load) headroom

Current design stage	Detailed Design
Notes	

Unique Ref.	Phase	Hazard description (before mitigation)	Incident type	Hazard affects	Is risk present in this option?	Risk without mitigation			Mitigation measures	Mitigation type	Risk with mitigation			Designer comments and assumptions
						Likelihood	Severity	Score			Likelihood	Severity	Score	
1	Operation	Failure to see queuing traffic	Multi-vehicle rear-shunt incident	Users	Yes	May happen: Once every 5-10 years	Serious harm: Serious injury or illness, substantial damage or loss	9 : Low	50mph speed limit to be provided on the interchange link; use of higher PSV surfacing (65 or 68+)	Reduce	Unlikely: Less than 1 per 10 years	Serious harm: Serious injury or illness, substantial damage or loss	6 : Low	
2	Operation	Object on the carriageway e.g. debris	Side swipe or loss of control due to impacting debris	Users	Yes	May happen: Once every 5-10 years	Moderate harm: Slight injury or illness, moderate damage or loss	6 : Low	50mph speed limit to be provided on the interchange link; use of higher PSV surfacing (65 or 68+)	Reduce	Unlikely: Less than 1 per 10 years	Moderate harm: Slight injury or illness, moderate damage or loss	4 : Low	Link is under motorway regulations
3	Operation	Collisions at merge	Side swipes	Users	Yes	May happen: Once every 5-10 years	Serious harm: Serious injury or illness, substantial damage or loss	9 : Low	50mph speed limit to be provided on the interchange link; use of higher PSV surfacing (65 or 68+); merge warning signing provided		Unlikely: Less than 1 per 10 years	Serious harm: Serious injury or illness, substantial damage or loss	6 : Low	The elevated view from the over bridge allows drivers time to gauge speed of traffic exiting J24, despite the reduced SSD
4	Operation	Bridge strike from high abnormal load vehicle (unplanned / unauthorised)	Collision with structure	Users	Yes	Very unlikely: Highly improbable, not known to occur	Major harm: Fatal injury, major damage or loss	4 : Low			Very unlikely: Highly improbable, not known to occur	Major harm: Fatal injury, major damage or loss	4 : Low	Very unlikely as the clearance is well above the 5.3m standard minimum for a new structure and 5.03m for an existing structure, the public documentation for high-load routes refers to this as an 18' route and an alternative route to the west of Castle Donington is available.
5	Operation	Diversion / congestion arising from the construction of the bridge, leading to rat running and/or driver frustration resulting in vehicle collisions	Shunt, side swipe or failure to give way incidents	Users	Yes	May happen: Once every 5-10 years	Moderate harm: Slight injury or illness, moderate damage or loss	6 : Low	Compliant traffic management. Form of structure to consider speed of construction to minimise delays		Unlikely: Less than 1 per 10 years	Moderate harm: Slight injury or illness, moderate damage or loss	4 : Low	Assumed to be isolated closures for bridge beam lifts/slide
6	Operation	Failure of surface water pumping station leading to flooding of the underpass	Aquaplaning / loss of control: single vehicle incident	Users	No	Risk not present	Risk not present	0 : Not present	N/a		Risk not present	Risk not present	0 : Not present	N/a
7	Operation	Failure of surface water pumping station leading to flooding of the underpass	Aquaplaning / loss of control: multi vehicle incident	Users	No	Risk not present	Risk not present	0 : Not present	N/a		Risk not present	Risk not present	0 : Not present	N/a
8	Operation	Failure of surface water pumping station leading to flooding of the underpass	Submerged vehicle / drowning	Users	No	Risk not present	Risk not present	0 : Not present	N/a		Risk not present	Risk not present	0 : Not present	N/a
9	Construction	Failure of surface water pumping station leading to flooding of the underpass: congestion due to link closure	General collisions on wider network	Users	No	Risk not present	Risk not present	0 : Not present	N/a		Risk not present	Risk not present	0 : Not present	N/a

Table D1 - Risk Value, likelihood and severity of outcomes that may be assigned to qualitative data for the purpose of assessment

Likelihood (L) x Severity (S) = Risk value (R)		Severity (S)				
		Minor Harm, Minor Damage or loss no injury	Moderate harm - slight injury or illness, moderate damage or loss	Serious harm - serious injury or illness, substantial loss or damage	Major harm - Fatal injury, major damage or loss	Extreme harm - Multiple fatalities, extreme loss or damage
Likelihood (L)	Very Unlikely - Highly Improbable not known to occur	1	2	3	4	5
	Unlikely - less than 1 per 10 years	2	4	6	8	10
	May Happen - Once every 5-10 years	3	6	9	12	15
	Likely - Once every 1-4 years	4	8	12	16	20
	Almost Certain - Once a year or more	5	10	15	20	25
Risk Value (R)		Required Action				
Low (1-9)		Ensure assumed control measures are maintained and reviewed as necessary				
Medium (10-19)		Additional control measures needed to reduce risk rating to a level which is equivalent to a test of "reasonably required" for the population concerned				
High (20-25)		Activity not permitted. Hazard avoided or risk to be reduced to tolerable				